

220A Walk-Behind Greensmower

Serial No. (030001—)

TECHNICAL MANUAL

**John Deere
Lawn & Grounds Care Division
TM1680 (01/Dec/96)**



This technical manual is written for an experienced technician and contains sections that are specifically for this product. It is a part of a total product support program.

The manual is organized so that all the information on a particular system is kept together. The order of grouping is as follows:

- Table of Contents
- Specifications
- Component Location
- System Schematic
- Theory of Operation
- Troubleshooting Chart
- Diagnostics
- Tests & Adjustments
- Repair

Note: Depending on the particular section or system being covered, not all of the above groups may be used.

Each section will be identified with a symbol rather than a number. The groups and pages within a section will be consecutively numbered.

All information, illustrations and specifications in this manual are based on the latest information available at the time of publication. The right is reserved to make changes at any time without notice.

We appreciate your input on this manual. To help, there are postage paid post cards included at the back. If you find any errors or want to comment on the layout of the manual please fill out one of the cards and mail it back to us.

COPYRIGHT® 1996
 JOHN DEERE LAWN AND
 GROUNDS CARE DIVISION
 Horicon, Wisconsin
 All rights reserved

Safety 

Specifications and General Information 

Engine (Honda GX120) 

Electrical 

Power Train 

Handlebars and Controls 

Brakes 

Cutting Unit 

Miscellaneous 



RECOGNIZE SAFETY INFORMATION



This is the safety-alert symbol. When you see this symbol on your machine or in this manual, be alert to the potential for personal injury.

Follow recommended precautions and safe servicing practices.

Understand Signal Words

A signal word—DANGER, WARNING, or CAUTION—is used with the safety-alert symbol. DANGER identifies the most serious hazards.

DANGER or WARNING safety signs are located near specific hazards. General precautions are listed on CAUTION safety signs. CAUTION also calls attention to safety messages in this manual.

REPLACE SAFETY SIGNS



Replace missing or damaged safety signs. See the machine operator's manual for correct safety sign placement.

HANDLE FLUIDS SAFELY-AVOID FIRES

Be Prepared For Emergencies

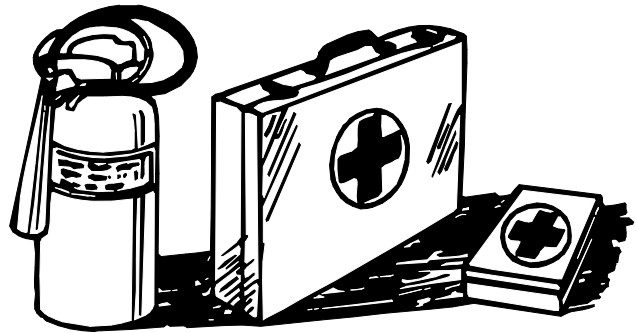

When you work around fuel, do not smoke or work near heaters or other fire hazards.

Store flammable fluids away from fire hazards. Do not incinerate or puncture pressurized containers.

Make sure machine is clean of trash, grease, and debris.

Do not store oily rags; they can ignite and burn spontaneously.

Be prepared if a fire starts.

Keep a first aid kit and fire extinguisher handy.

Keep emergency numbers for doctors, ambulance service, hospital, and fire department near your telephone.

USE SAFE SERVICE PROCEDURES

Wear Protective Clothing

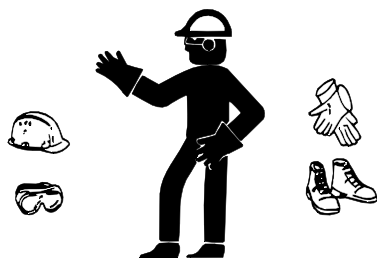

Wear close fitting clothing and safety equipment appropriate to the job.

Prolonged exposure to loud noise can cause impairment or loss of hearing. Wear a suitable hearing protective device such as earmuffs or earplugs to protect against objectionable or uncomfortable loud noises.

Operating equipment safely requires the full attention of the operator. Do not wear radio or music headphones while operating machine.

Service Machines Safely

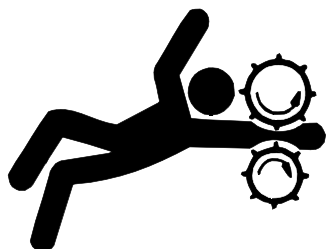

Tie long hair behind your head. Do not wear a necktie, scarf, loose clothing, or necklace when you work near machine tools or moving parts. If these items were to get caught, severe injury could result.

Remove rings and other jewelry to prevent electrical shorts and entanglement in moving parts.

Use Proper Tools

Use tools appropriate to the work. Makeshift tools and procedures can create safety hazards. Use power tools only to loosen threaded parts and fasteners. For loosening and tightening hardware, use the correct size tools. **DO NOT** use U.S. measurement tools on metric fasteners. Avoid bodily injury caused by slipping wrenches. Use only service parts meeting John Deere specifications.

Park Machine Safely

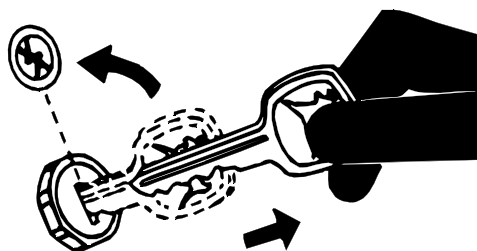

Before working on the machine:

1. Lower all equipment to the ground.
2. Stop the engine and remove the key.
3. Disconnect the battery ground strap.
4. Hang a "DO NOT OPERATE" tag in operator station.

Support Machine Properly And Use Proper Lifting Equipment

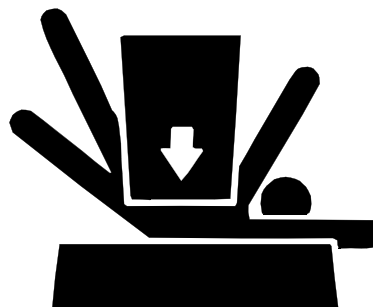

If you must work on a lifted machine or attachment, securely support the machine or attachment.

Do not support the machine on cinder blocks, hollow tiles, or props that may crumble under continuous load. Do not work under a machine that is supported solely by a jack. Follow recommended procedures in this manual.

Lifting heavy components incorrectly can cause severe injury or machine damage. Follow recommended procedure for removal and installation of components in the manual.

Work In Clean Area

Before starting a job:

1. Clean work area and machine.
2. Make sure you have all necessary tools to do your job.
3. Have the right parts on hand.
4. Read all instructions thoroughly; do not attempt shortcuts.



Illuminate Work Area Safely

Illuminate your work area adequately but safely. Use a portable safety light for working inside or under the machine. Make sure the bulb is enclosed by a wire cage. The hot filament of an accidentally broken bulb can ignite spilled fuel or oil.

Work In Ventilated Area

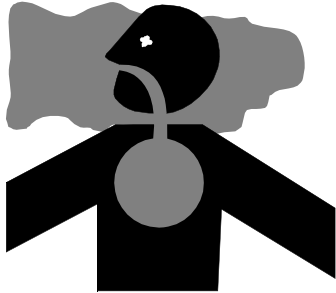

Engine exhaust fumes can cause sickness or death. If it is necessary to run an engine in an enclosed area, remove the exhaust fumes from the area with an exhaust pipe extension.

If you do not have an exhaust pipe extension, open the doors and get outside air into the area.

WARNING: California Proposition 65 Warning

Gasoline engine exhaust from this product contains chemicals known to the State of California to cause cancer, birth defects, or other reproductive harm.

Remove Paint Before Welding Or Heating

Avoid potentially toxic fumes and dust. Hazardous fumes can be generated when paint is heated by welding, soldering, or using a torch. Do all work outside or in a well ventilated area. Dispose of paint and solvent properly. Remove paint before welding or heating: If you sand or grind paint, avoid breathing the dust. Wear an approved respirator. If you use solvent or paint stripper, remove stripper with soap and water before welding. Remove solvent or paint stripper containers and other flammable material from area. Allow fumes to disperse at least 15 minutes before welding or heating.

Avoid Harmful Asbestos Dust

Avoid breathing dust that may be generated when handling components containing asbestos fibers. Inhaled asbestos fibers may cause lung cancer.

Components in products that may contain asbestos fibers are brake pads, brake band and lining assemblies, clutch plates, and some gaskets. The asbestos used in these components is usually found in a resin or sealed in some way. Normal handling is not hazardous as long as airborne dust containing asbestos is not generated.

Avoid creating dust. Never use compressed air for cleaning. Avoid brushing or grinding material containing asbestos. When servicing, wear an approved respirator. A special vacuum cleaner is recommended to clean asbestos. If not available, apply a mist of oil or water on the material containing asbestos. Keep bystanders away from the area.

SERVICE TIRES SAFELY



Explosive separation of a tire and rim parts can cause serious injury or death.

Do not attempt to mount a tire unless you have the proper equipment and experience to perform the job. Always maintain the correct tire pressure. Do not inflate the tires above the recommended pressure. Never weld or heat a wheel and tire assembly. The heat can cause an increase in air pressure resulting in a tire explosion. Welding can structurally weaken or deform the wheel.

When inflating tires, use a clip-on chuck and extension hose long enough to allow you to stand to one side and NOT in front of or over the tire assembly. Use a safety cage if available.

Check wheels for low pressure, cuts, bubbles, damaged rims or missing lug bolts and nuts.

AVOID INJURY FROM ROTATING BLADES, AUGERS AND PTO SHAFTS

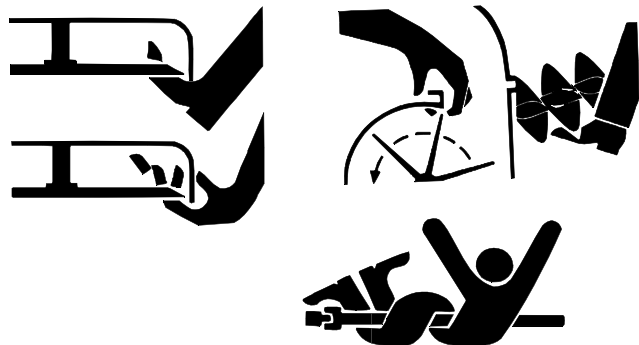

Keep hands and feet away while machine is running. Shut off power to service, lubricate or remove mower blades, augers or PTO shafts.

HANDLE CHEMICAL PRODUCTS SAFELY

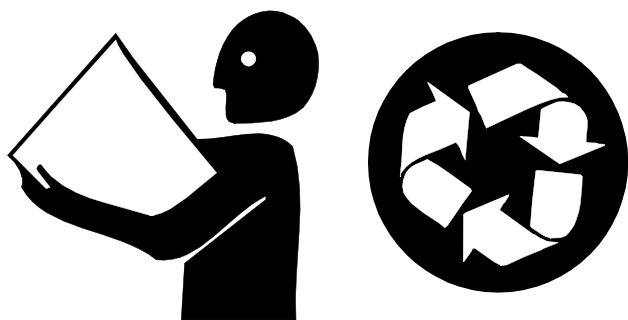

Direct exposure to hazardous chemicals can cause serious injury. Potentially hazardous chemicals used with John Deere equipment include such items as lubricants, coolants, paints, and adhesives.

A Material Safety Data Sheet (MSDS) provides specific details on chemical products: physical and health hazards, safety procedures, and emergency response techniques. Check the MSDS before you start any job using a hazardous chemical. That way you will know exactly what the risks are and how to do the job safely. Then follow procedures and recommended equipment.

Dispose of Waste Properly

Improperly disposing of waste can threaten the environment and ecology. Potentially harmful waste used with John Deere equipment include such items as oil, fuel, coolant, brake fluid, filters, and batteries. Use leakproof containers when draining fluids. Do not use food or beverage containers that may mislead someone into drinking from them. Do not pour waste onto the ground, down a drain, or into any water source. Inquire on the proper way to recycle or dispose of waste from your local environmental or recycling center, or from your John Deere dealer.



LIVE WITH SAFETY



Before returning machine to customer, make sure machine is functioning properly, especially the safety systems. Install all guards and shields.



This page intentionally left blank.

CONTENTS

Page



SPECIFICATIONS AND GENERAL INFORMATION

GENERAL SPECIFICATIONS

VEHICLE SPECIFICATIONS 2-2

REPAIR INFORMATION

METRIC FASTENER TORQUE VALUES 2-4

INCH FASTENER TORQUE VALUES 2-5

GASOLINE

4-CYCLE ENGINES—NORTH AMERICA 2-6

GASOLINE STORAGE 2-6

4-CYCLE ENGINES—EUROPE 2-7

GASOLINE STORAGE 2-7

OILS AND LUBRICANTS

4-CYCLE GASOLINE ENGINE OIL—NORTH AMERICA 2-8

4-CYCLE GASOLINE ENGINE OIL—EUROPE 2-9

SPEED REDUCER OIL—NORTH AMERICA 2-10

SPEED REDUCER OIL—EUROPE 2-10

REEL SUPPORT GREASE—NORTH AMERICA 2-11

REEL SUPPORT GREASE—EUROPE 2-11

ANTI-CORROSION GREASE 2-12

GREASE—NORTH AMERICA 2-13

GREASE—EUROPE 2-13

ALTERNATIVE LUBRICANTS 2-14

SYNTHETIC LUBRICANTS 2-14

LUBRICANT STORAGE 2-14

MIXING OF LUBRICANTS 2-14

SERIAL NUMBER LOCATIONS

SERIAL NUMBER LOCATION 2-15

MACHINE IDENTIFICATION NUMBER 2-15

ENGINE SERIAL NUMBER 2-15

CARBURETOR IDENTIFICATION NUMBER 2-15

OPERATIONAL CHECKOUT PROCEDURES

ENGINE OIL LEVEL CHECK 2-16

SPEED REDUCER OIL LEVEL CHECK 2-16

THROTTLE LEVER CHECK 2-17

OPERATOR PRESENCE BAIL CHECK 2-18

PARK BRAKE CHECK 2-18

TRAVEL CLUTCH CHECK 2-19

REEL CLUTCH CHECK 2-19

GENERAL SPECIFICATIONS

VEHICLE SPECIFICATIONS



ENGINE

Make	Honda
Type	Gasoline, 25° Incline
Model	GX120 K1LJD2
Aspiration	Natural
Horsepower	3.1 kW (4.0 hp)
Cylinders	1
Displacement	118 cm ³ (7.2 cu in.)
Stroke/Cycle	4 Cycle
Bore	60 mm (2.4 in.)
Stroke	42 mm (1.7 in.)
Compression Ratio	8.5:1
Slow Idle	1400 +220/-150 rpm
Fast Idle	3450 ±150 rpm
Timing	25° BTDC
Valving	Overhead Valves
Lubrication	Splash
Cooling System	Forced Air
Air Cleaner	Dual-Element (Silent) Type
Carburetor	Externally Vented
Muffler	In-line
Engine Oil Capacity	0.56 L (0.59 qt)
Type of Starter	Recoil
Weight	15.5 kg. (34.2 lb)

FUEL SYSTEM

Fuel Tank Location	On Engine
Fuel Tank Capacity	2.5 L (0.66 gal)
Fuel (minimum octane)	Unleaded Gasoline, 87 Octane
Fuel Delivery	Gravity
Carburetor	Float-type Side Draft
Fuel Filter	Screen

ELECTRICAL

Ignition	Transistorized Magneto
----------------	------------------------

DRIVE TRAIN/TRAVELING DEVICE

Traction Roller	Smooth Surface, Dual Aluminium
Traveling Speed	
Forward Speed	9.2 km/h (5.5 mph)
Mow Speed	3.4 km/h (5.5 mph)
Front Roller	Machined Steel, Solid or Grooved

BRAKES

Park Brake	Band Type, lever Activated
------------------	----------------------------

CUTTING UNIT

Cutting Width	559 mm (22 in.)
Cutting Height (minimum)	
Standard—3.0 mm Bedknife	3.2 mm (1/8 in.)
Optional—2.5 mm Bedknife	2.8 mm (7/64 in.)
Cutting Height (maximum)	22.2 mm (7/8 in.)
Frequency of Clip	5 mm (0.195 in.)
Reel	
Diameter	127 mm (5 in.)
Number of Blades	11
Material	Heat Treated Special Alloy Steel
Grass Catcher	Rotational Moulded Poly Propylene



WEIGHTS AND DIMENSIONS

Weight (less GTC and Wheels, with Grass Catcher)	99.5 kg (219 lb)
Width	946 mm (37.25 in.)
Length	940 mm (37.00 in.)
Height	1.119 m (46.8 in.)

WHEELS AND TIRES

Size	4.1-6 (2 pr) Tubeless
Pressure	125—140 kPa (18—20 psi)

(Specifications and design subject to change without notice.)

METRIC FASTENER TORQUE VALUES

Property Class and Head Markings	4.8		8.8		9.8		10.9		12.9	
Property Class and Nut Markings	5		10		10		10		12	

TS1163

SIZE	Class 4.8				Class 8.8 or 9.8				Class 10.9				Class 12.9			
	Lubricated ^a		Dry ^a		Lubricated ^a		Dry ^a		Lubricated ^a		Dry ^a		Lubricated ^a		Dry ^a	
	N•m	lb-ft	N•m	lb-ft	N•m	lb-ft	N•m	lb-ft	N•m	lb-ft	N•m	lb-ft	N•m	lb-ft	N•m	lb-ft
M6	4.8	3.5	6	4.5	9	6.5	11	8.5	13	9.5	17	12	15	11.5	19	14.5
M8	12	8.5	15	11	22	16	28	20	32	24	40	30	37	28	47	35
M10	23	17	29	21	43	32	55	40	63	47	80	60	75	55	95	70
M12	40	29	50	37	75	55	95	70	110	80	140	105	130	95	165	120
M14	63	47	80	60	120	88	150	110	175	130	225	165	205	150	260	109
M16	100	73	125	92	190	140	240	175	275	200	350	225	320	240	400	300
M18	135	100	175	125	260	195	330	250	375	275	475	350	440	325	560	410
M20	190	140	240	180	375	275	475	350	530	400	675	500	625	460	800	580
M22	260	190	330	250	510	375	650	475	725	540	925	675	850	625	1075	800
M24	330	250	425	310	650	475	825	600	925	675	1150	850	1075	800	1350	1000
M27	490	360	625	450	950	700	1200	875	1350	1000	1700	1250	1600	1150	2000	1500
M30	675	490	850	625	1300	950	1650	1200	1850	1350	2300	1700	2150	1600	2700	2000
M33	900	675	1150	850	1750	1300	2200	1650	2500	1850	3150	2350	2900	2150	3700	2750
M36	1150	850	1450	1075	2250	1650	2850	2100	3200	2350	4050	3000	3750	2750	4750	3500

DO NOT use these hand torque values if a different torque value or tightening procedure is given for a specific application. Torque values listed are for general use only and include a ±10% variance factor. Check tightness of fasteners periodically. DO NOT use air powered wrenches.

Shear bolts are designed to fail under predetermined loads. Always replace shear bolts with identical grade.

Fasteners should be replaced with the same class. Make sure fastener threads are clean and that you properly start thread engagement. This will prevent them from failing when tightening.

When bolt and nut combination fasteners are used, torque values should be applied to the **NUT** instead of the bolt head.









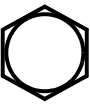

Tighten toothed or serrated-type lock nuts to the full torque value.

^a "Lubricated" means coated with a lubricant such as engine oil, or fasteners with phosphate and oil coatings. "Dry" means plain or zinc plated (yellow dichromate - Specification JDS117) without any lubrication.

Reference: JDS—G200.

INCH FASTENER TORQUE VALUES



SAE Grade and Head Markings	1 or 2 ^b No Marks 	5  5.1  5.2 	8  8.2 
	2 No Marks 	5  	8  

TS1162

SIZE	Grade 1				Grade 2 ^b				Grade 5, 5.1 or 5.2				Grade 8 or 8.2			
	Lubricated ^a		Dry ^a		Lubricated ^a		Dry ^a		Lubricated ^a		Dry ^a		Lubricated ^a		Dry ^a	
	N•m	lb-ft	N•m	lb-ft	N•m	lb-ft	N•m	lb-ft	N•m	lb-ft	N•m	lb-ft	N•m	lb-ft	N•m	lb-ft
1/4	3.7	2.8	4.7	3.5	6	4.5	7.5	5.5	9.5	7	12	9	13.5	10	17	12.5
5/16	7.7	5.5	10	7	12	9	15	11	20	15	25	18	28	21	35	26
3/8	14	10	17	13	22	16	27	20	35	26	44	33	50	36	63	46
7/16	22	16	28	20	35	26	44	32	55	41	70	52	80	58	100	75
1/2	33	25	42	31	53	39	67	50	85	63	110	80	120	90	150	115
9/16	48	36	60	45	75	56	95	70	125	90	155	115	175	130	225	160
5/8	67	50	85	62	105	78	135	100	170	125	215	160	215	160	300	225
3/4	120	87	150	110	190	140	240	175	300	225	375	280	425	310	550	400
7/8	190	140	240	175	190	140	240	175	490	360	625	450	700	500	875	650
1	290	210	360	270	290	210	360	270	725	540	925	675	1050	750	1300	975
1-1/8	470	300	510	375	470	300	510	375	900	675	1150	850	1450	1075	1850	1350
1-1/4	570	425	725	530	570	425	725	530	1300	950	1650	1200	2050	1500	2600	1950
1-3/8	750	550	950	700	750	550	950	700	1700	1250	2150	1550	2700	2000	3400	2550
1-1/2	1000	725	1250	925	990	725	1250	930	2250	1650	2850	2100	3600	2650	4550	3350

DO NOT use these hand torque values if a different torque value or tightening procedure is given for a specific application. Torque values listed are for general use only and include a ±10% variance factor. Check tightness of fasteners periodically. DO NOT use air powered wrenches.

Shear bolts are designed to fail under predetermined loads. Always replace shear bolts with identical grade.

Fasteners should be replaced with the same grade. Make sure fastener threads are clean and that you properly start thread engagement. This will prevent them from failing when tightening.

When bolt and nut combination fasteners are used, torque values should be applied to the **NUT** instead of the bolt head.

Tighten toothed or serrated-type lock nuts to the full torque value.

^a "Lubricated" means coated with a lubricant such as engine oil, or fasteners with phosphate and oil coatings. "Dry" means plain or zinc plated (yellow dichromate - Specification JDS117) without any lubrication.

^b "Grade 2" applies for hex cap screws (not hex bolts) up to 152 mm (6-in.) long. "Grade 1" applies for hex cap screws over 152 mm (6-in.) long, and for all other types of bolts and screws of any length.

Reference: JDS—G200.

GASOLINE 4-CYCLE ENGINES—NORTH AMERICA



CAUTION

Gasoline is **HIGHLY FLAMMABLE**, handle it with care.

DO NOT refuel machine while:

- indoors, always fill gas tank outdoors;
- machine is near an open flame or sparks;
- engine is running, **STOP** engine;
- engine is hot, allow it to cool sufficiently first;
- smoking.

Help prevent fires:

- fill gas tank to bottom of filler neck only;
- be sure fill cap is tight after fueling;
- clean up any gas spills **IMMEDIATELY**;
- keep machine clean and in good repair—free of excess grease, oil, debris, and faulty or damaged parts;
- any storage of machines with gas left in tank should be in an area that is well ventilated to prevent possible igniting of fumes by an open flame or spark, this includes any appliance with a pilot light.

To prevent fire or explosion caused by **STATIC ELECTRIC DISCHARGE** during fueling:

- **ONLY** use a clean, approved **POLYETHYLENE PLASTIC** fuel container and funnel **WITHOUT** any metal screen or filter.

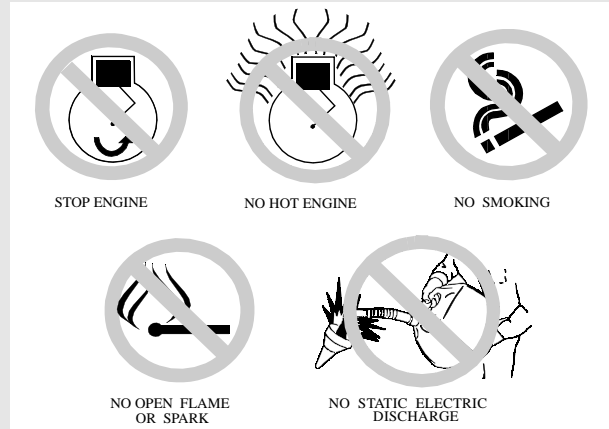

To avoid engine damage:

- DO NOT mix oil with gasoline;
- **ONLY** use clean, fresh unleaded gasoline with an octane rating (anti-knock index) of 87 or higher;
- fill gas tank at the end of each day's operation to help prevent condensation from forming inside a partially filled tank;
- keep up with specified service intervals.

Use of alternative oxygenated, gasohol blended, unleaded gasoline is acceptable as long as:

- the ethyl or grain alcohol blends DO NOT exceed 10% by volume or
- methyl tertiary butyl ether (MTBE) blends DO NOT exceed 15% by volume.

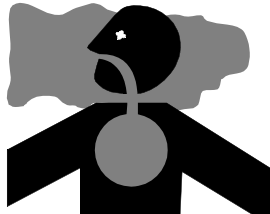

IMPORTANT: DO NOT use **METHANOL** gasolines because **METHANOL** is harmful to the environment and to your health.



WARNING

California Proposition 65 Warning: Gasoline engine exhaust from this product contains chemicals known to the State of California to cause cancer, birth defects, or other reproductive harm.

GASOLINE STORAGE

IMPORTANT: Keep all dirt, scale, water or other foreign material out of gasoline.

Keep gasoline stored in a safe, protected area. Storage of gasoline in a clean, properly marked ("**UNLEADED GASOLINE**") **POLYETHYLENE PLASTIC** container **WITHOUT** any metal screen or filter is recommended. **DO NOT** use de-icers to attempt to remove water from gasoline or depend on fuel filters to remove water from gasoline. Use a water separator installed in the storage tank outlet. **BE SURE** to properly discard unstable or contaminated gasoline. When storing unit or gasoline, it is recommended that you add **John Deere Gasoline Conditioner and Stabilizer (TY15977)** or an equivalent to the gasoline. **BE SURE** to follow directions on container and to properly discard empty container.

4-CYCLE ENGINES—EUROPE



CAUTION

Gasoline is **HIGHLY FLAMMABLE**, handle it with care.

DO NOT refuel machine while:

- indoors, always fill gas tank outdoors;
- machine is near an open flame or sparks;
- engine is running, **STOP** engine;
- engine is hot, allow it to cool sufficiently first;
- smoking.

Help prevent fires:

- fill gas tank to bottom of filler neck only;
- be sure fill cap is tight after fueling;
- clean up any gas spills **IMMEDIATELY**;
- keep machine clean and in good repair—free of excess grease, oil, debris, and faulty or damaged parts;
- any storage of machines with gas left in tank should be in an area that is well ventilated to prevent possible igniting of fumes by an open flame or spark, this includes any appliance with a pilot light.

To prevent fire or explosion caused by STATIC ELECTRIC DISCHARGE during fueling:

- **ONLY** use a clean, approved **POLYETHYLENE PLASTIC** fuel container and funnel **WITHOUT** any metal screen or filter.

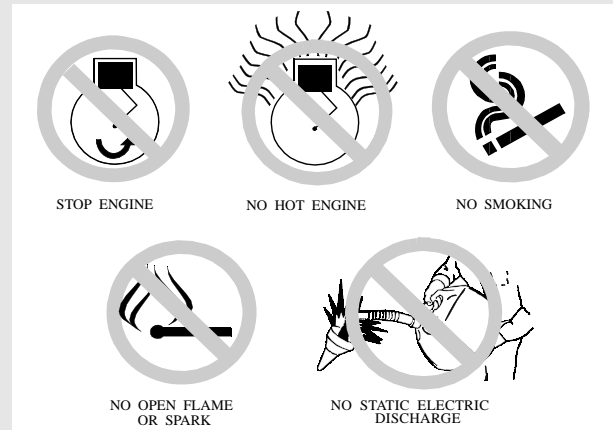

To avoid engine damage:

- DO NOT mix oil with gasoline;
- **ONLY** use clean, fresh unleaded gasoline with an octane rating (anti-knock index) of 87 or higher;
- fill gas tank at the end of each day's operation to help prevent condensation from forming inside a partially filled tank;
- keep up with specified service intervals.

Use of alternative oxygenated, gasohol blended, unleaded gasoline is acceptable as long as:

- the ethyl or grain alcohol blends DO NOT exceed 10% by volume or
- methyl tertiary butyl ether (MTBE) blends DO NOT exceed 15% by volume.

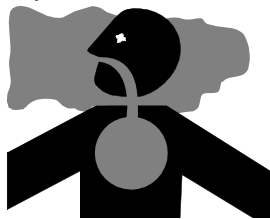

IMPORTANT: DO NOT use **METHANOL** gasolines because **METHANOL** is harmful to the environment and to your health.

GASOLINE STORAGE

IMPORTANT: Keep all dirt, scale, water or other foreign material out of gasoline.

Keep gasoline stored in a safe, protected area. Storage of gasoline in a clean, properly marked ("**UNLEADED GASOLINE**") **POLYETHYLENE PLASTIC** container **WITHOUT** any metal screen or filter is recommended. **DO NOT** use de-icers to attempt to remove water from gasoline or depend on fuel filters to remove water from gasoline. Use a water separator installed in the storage tank outlet. **BE SURE** to properly discard unstable or contaminated gasoline. When storing unit or gasoline, it is recommended that you add **John Deere Gasoline Conditioner and Stabilizer (TY15977)** or an equivalent to the gasoline. **BE SURE** to follow directions on container and to properly discard empty container.

OILS AND LUBRICANTS

4-CYCLE GASOLINE ENGINE OIL— NORTH AMERICA

Use the appropriate oil viscosity based on the expected air temperature range during the period between recommended oil changes. Operating outside of these recommended oil air temperature ranges may cause premature engine failure.

NOTE: For a new or rebuilt engine, the oil should be changed after first 20 hours of use.

The following John Deere oils are **PREFERRED**:

- **PLUS-4[®]—SAE 10W-30;**
- **TORQ-GARD SUPREME[®]—SAE 5W-30.**

The following John Deere oils are **also recommended**, based on their specified temperature range:

- **TURF-GARD[®]—SAE 10W-30;**
- **PLUS-4[®]—SAE 10W-40;**
- **TORQ-GARD SUPREME[®]—SAE 30.**

Other oils may be used if above John Deere oils are not available, provided they meet one of the following specifications:

- SAE 5W-30—API Service Classification SG or higher;
- SAE 10W-30—API Service Classification SG or higher;
- SAE 30—API Service Classification SC or higher.

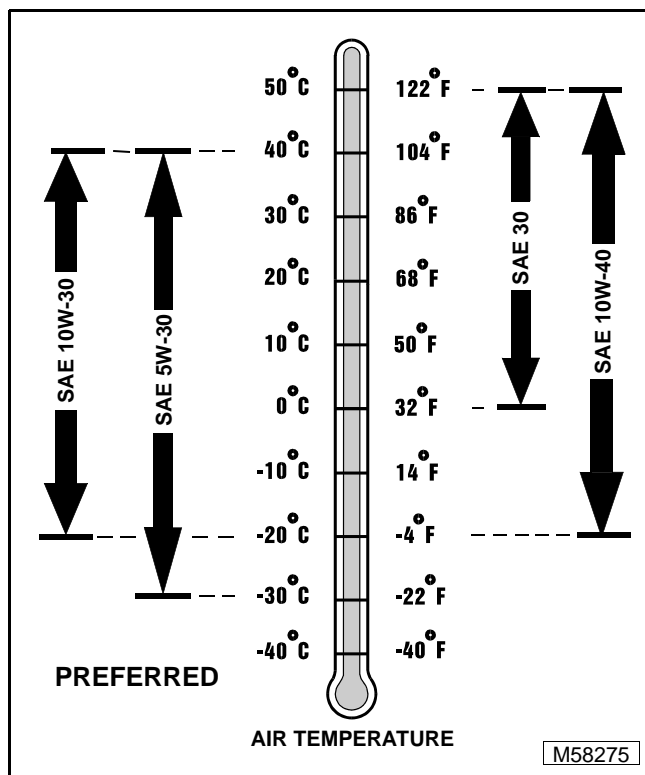

John Deere Distributors: You may want to cross-reference the following publications to recommend the proper oil for your customers:

- Module DX, ENOIL2 in JDS-G135;
- Section 530, Lubricants & Hydraulics, of the John Deere Merchandise Sales Guide;
- Lubrication Sales Manual PI7032.

4-CYCLE GASOLINE ENGINE OIL—EUROPE

Use the appropriate oil viscosity based on the expected air temperature range during the period between recommended oil changes. Operating outside of these recommended oil air temperature ranges may cause premature engine failure.

NOTE: For a new or rebuilt engine, the oil should be changed after first 20 hours of use.

The following John Deere oils are **PREFERRED**:

- **UNI-GARD™—SAE 10W-30;**
- **TORQ-GARD SUPREME®—SAE 5W-30;**
- **UNI-GARD™—SAE 5W-30.**

The following John Deere oils are **also recommended**, based on their specified temperature range:

- **TORQ-GARD SUPREME®—SAE 10W-30;**
- **UNI-GARD™—SAE 10W-40;**
- **TORQ-GARD SUPREME®—SAE 30;**
- **UNI-GARD™—SAE 30.**

Other oils may be used if above John Deere oils are not available, provided they meet one of the following specifications:

- CCMC Specification G4 or higher.

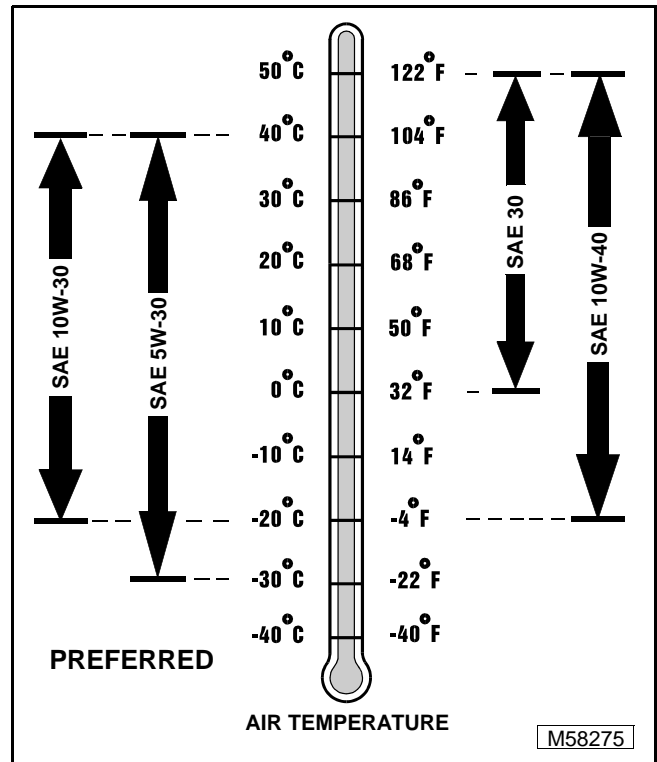

John Deere Distributors: You may want to cross-reference the following publications to recommend the proper oil for your customers:

- Module DX, ENOIL2 in JDS-G135;
- Section 530, Lubricants & Hydraulics, of the John Deere Merchandise Sales Guide.

SPEED REDUCER OIL—NORTH AMERICA

Use the appropriate oil viscosity based on the air temperature ranges. Operating outside of these recommended oil air temperature ranges may cause premature gear case failure.

IMPORTANT: ONLY use a quality oil in this gear case. DO NOT mix any other oils in this gear case. DO NOT use BIO-HY-GARD® in this gear case.

The following John Deere gear case oil is **PREFERRED**:

- **GL-5 GEAR LUBRICANT®—SAE 80W-90.**

The following John Deere gear case oil is **also recommended** if above preferred oil is not available:

- **GL-5 GEAR LUBRICANT®—SAE 85W-140.**

Other gear case oils may be used if above recommended John Deere gear case oils are not available, provided they meet the following specification:

- API Service Classification GL-5.

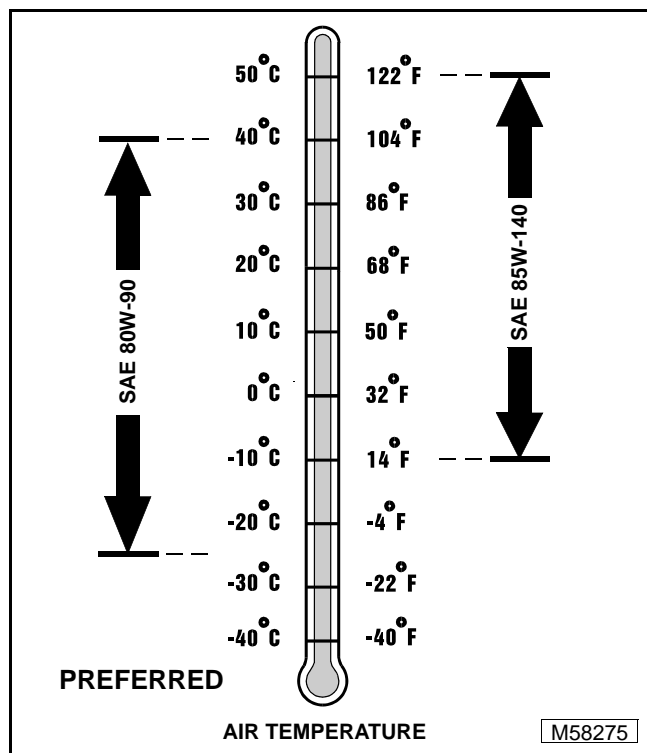

John Deere Distributors: You may want to cross-reference the following publications to recommend the proper oil for your customers:

- Module DX,GEOIL in JDS-G135;
- Section 530, Lubricants & Hydraulics, of the John Deere Merchandise Sales Guide;
- Lubrication Sales Manual PI7032.

SPEED REDUCER OIL—EUROPE

Use the appropriate oil viscosity based on the air temperature ranges. Operating outside of these recommended oil air temperature ranges may cause premature gear case failure.

IMPORTANT: ONLY use a quality oil in this gear case. DO NOT mix any other oils in this gear case. DO NOT use BIO-HY-GARD® in this gear case.

The following John Deere gear case oil is **PREFERRED**:

- **EXTREME-GARD™—SAE 80W-90.**

The following John Deere gear case oil is **also recommended** if above preferred oil is not available:

- **EXTREME-GARD™—SAE 85W-140.**

Other gear case oils may be used if above recommended John Deere gear case oils are not available, provided they meet the following specification:

- API Service Classification GL-5.

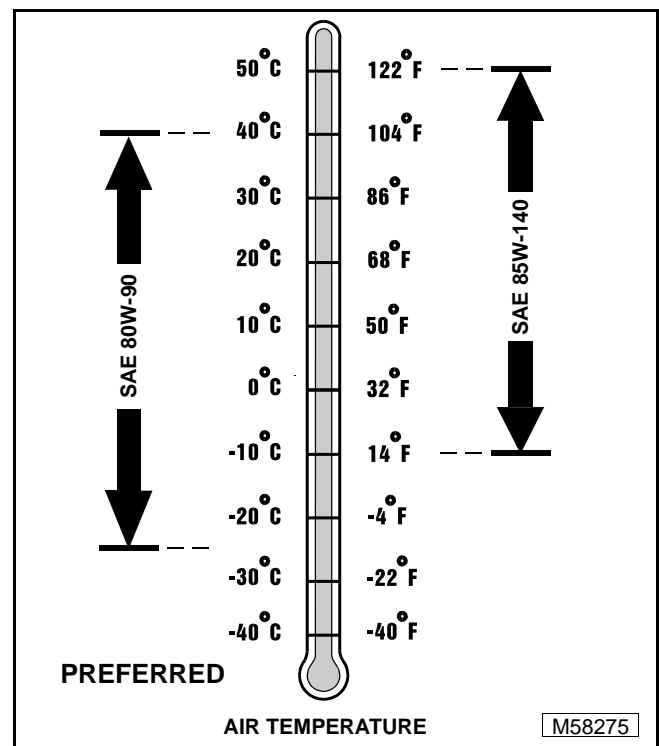

John Deere Distributors: You may want to cross-reference the following publications to recommend the proper oil for your customers:

- Module DX,GEOIL in JDS-G135;
- Section 530, Lubricants & Hydraulics, of the John Deere Merchandise Sales Guide.

REEL SUPPORT GREASE—NORTH AMERICA

Use the following reel support greases based on the air temperature range. Operating outside of the recommended grease air temperature range may cause premature reel support failure.

The following John Deere grease is **PREFERRED**:

- **CORN HEAD GREASE—JDM J13E6, NLGI Grade 0 (Polyurea Grease).**

Other greases may be used if above John Deere greases are not available, provided they **meet the following compatibility specifications only**:

- Polyurea Grease—NLGI Grade 0;
- Calcium Complex Grease—NLGI Grade 0.

IMPORTANT: DO NOT mix any other greases (including calcium, lithium, lithium complex, and lithium 12-hydroxy based greases) with above recommended greases, they are NOT COMPATIBLE. For best results, completely remove all non-compatible grease from housing and fill with above preferred grease or one of the other greases, which are compatible with each other. DO NOT use any BIO-GREASE.

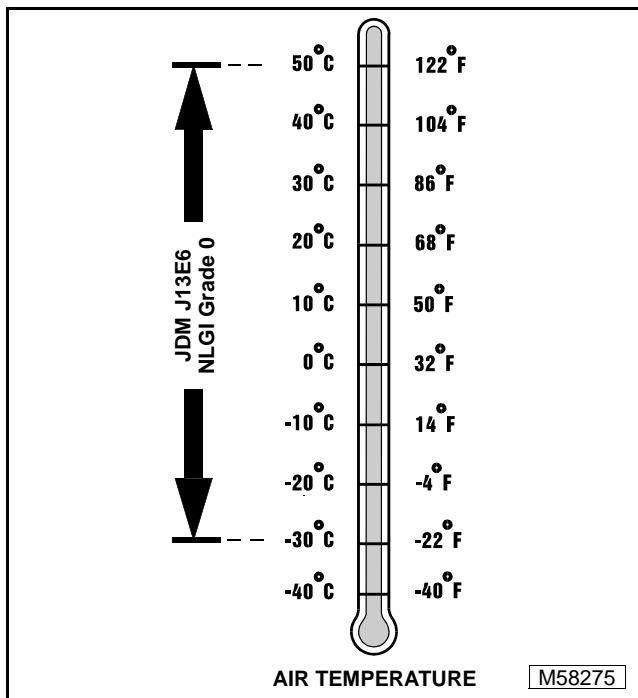

John Deere Distributors: You may want to cross-reference the following publications to recommend the proper grease for your customers:

- Module DX,CORN in JDS-G135;
- Section 530, Lubricants & Hydraulics, of the John Deere Merchandise Sales Guide;
- Lubrication Sales Manual PI7032.

REEL SUPPORT GREASE—EUROPE

Use the following reel support greases based on the air temperature range. Operating outside of the recommended grease air temperature range may cause premature reel support failure.

The following John Deere grease is **PREFERRED**:

- **GREASE-GARD®—JDM J13E6, NLGI Grade 0.**

Other greases may be used if above preferred John Deere grease is not available, provided they **meet the following compatibility specifications only**:

- Polyurea Grease—NLGI Grade 0;
- Calcium Complex Grease—NLGI Grade 0.

IMPORTANT: DO NOT mix any other greases (including calcium, lithium, lithium complex, and lithium 12-hydroxy based greases) with above recommended greases, they are NOT COMPATIBLE. For best results, completely remove all non-compatible grease from housing and fill with above preferred grease or one of the other greases, which are compatible with each other. DO NOT use any BIO-GREASE.

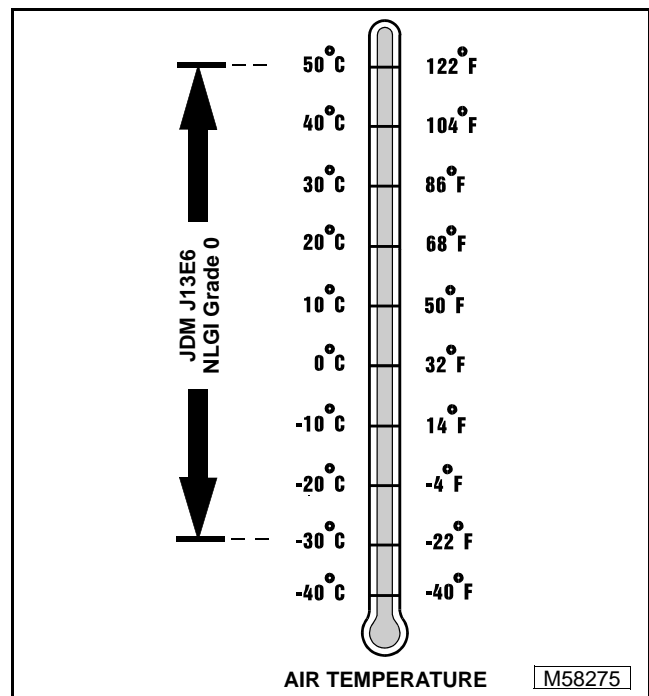

John Deere Distributors: You may want to cross-reference the following publications to recommend the proper grease for your customers:

- Module DX,CORN in JDS-G135;
- Section 530, Lubricants & Hydraulics, of the John Deere Merchandise Sales Guide.

ANTI-CORROSION GREASE SPECIFICATIONS

This anti-corrosion grease is formulated to provide the best protection against absorbing moisture, which is one of the major causes of corrosion. This grease is also superior in its resistance to separation and migration.

The following anti-corrosion grease is **PREFERRED**:

- **DuBois MPG-2[®] Multi-Purpose Polymer Grease—M79292.**

Other greases may be used if they meet or exceed the following specifications:

- John Deere Standard JDM J13A2, NLGI Grade 1.

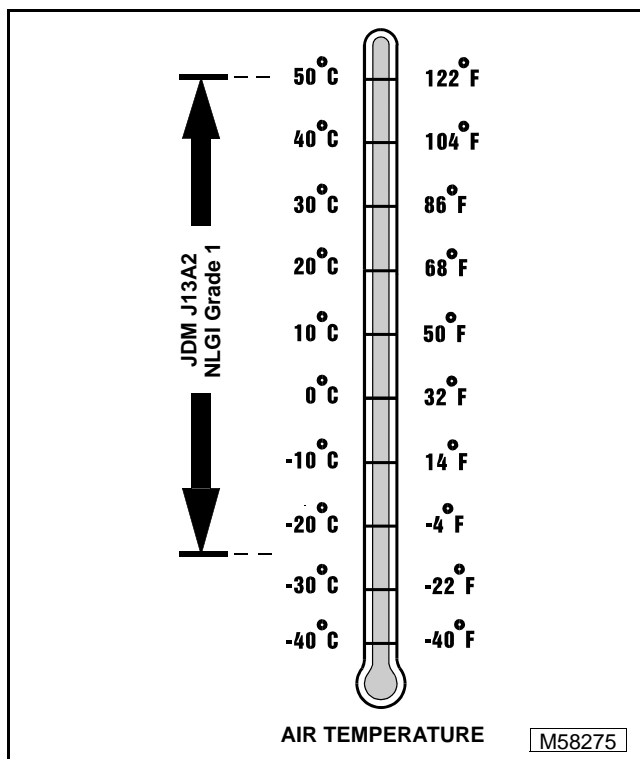

John Deere Distributors: You may want to cross-reference the following publications to recommend the proper grease for your customers:

- Module DX,GREA1 in JDS–G135;
- Section 530, Lubricants & Hydraulics, of the John Deere Merchandise Sales Guide;
- Lubrication Sales Manual PI7032.

GREASE—NORTH AMERICA

Use the following grease based on the air temperature range. Operating outside of the recommended grease air temperature range may cause premature failures.

IMPORTANT: ONLY use a quality grease in this application. DO NOT mix any other greases in this application. DO NOT use any BIO-GREASE in this application.

The following John Deere grease is **PREFERRED**:

- **NON-CLAY HIGH-TEMPERATURE EP GREASE®—JDM J13E4, NLGI Grade 2.**

Other greases may be used if above preferred John Deere grease is not available, provided they meet the following specification:

- John Deere Standard JDM J13E4, NLGI Grade 2.

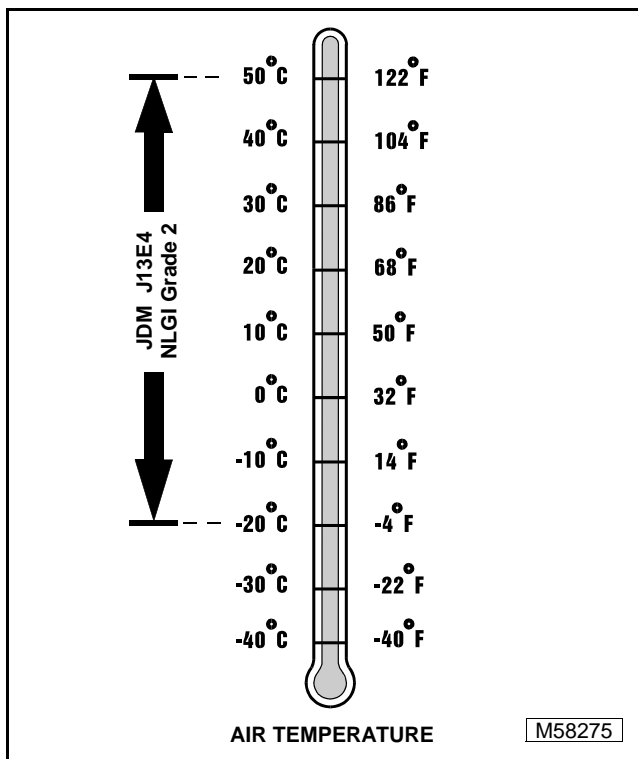

John Deere Distributors: You may want to cross-reference the following publications to recommend the proper grease for your customers:

- Module DX,GREA1 in JDS-G135;
- Section 530, Lubricants & Hydraulics, of the John Deere Merchandise Sales Guide;
- Lubrication Sales Manual PI7032.

GREASE—EUROPE

Use the following grease based on the air temperature range. Operating outside of the recommended grease air temperature range may cause premature failures.

IMPORTANT: ONLY use a quality grease in this application. DO NOT mix any other greases in this application. DO NOT use any BIO-GREASE in this application.

The following John Deere grease is **PREFERRED**:

- **GREASE-GARD™—JDM J13E4, NLGI Grade 2.**

Other greases may be used if above preferred John Deere grease is not available, provided they meet the following specification:

- John Deere Standard JDM J13E4, NLGI Grade 2.

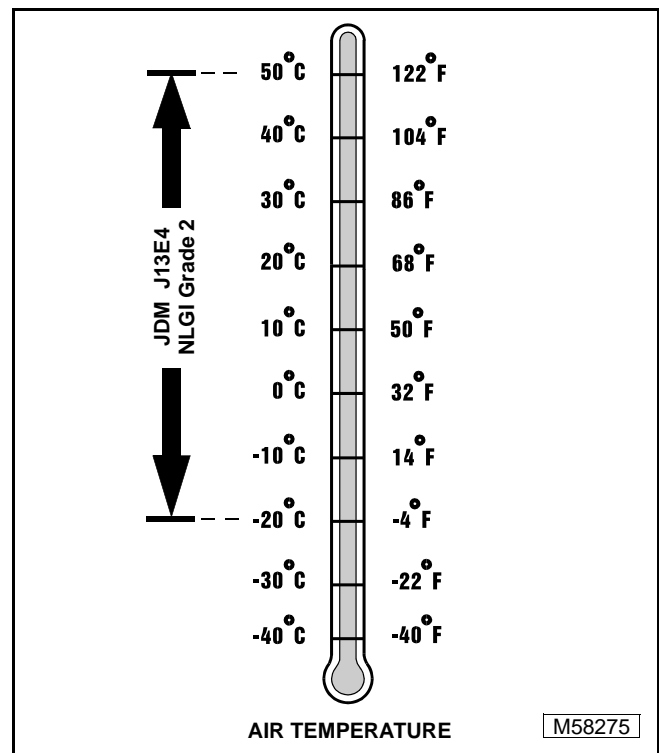

John Deere Distributors: You may want to cross-reference the following publications to recommend the proper grease for your customers:

- Module DX,GREA1 in JDS-G135;
- Section 530, Lubricants & Hydraulics, of the John Deere Merchandise Sales Guide.

ALTERNATIVE LUBRICANTS

Conditions in certain geographical areas outside the United States and Canada may require different lubricant recommendations than the ones printed in this technical manual or the operator's manual. Consult with your John Deere Dealer, or Sales Branch, to obtain the alternative lubricant recommendations.



IMPORTANT: Use of alternative lubricants could cause reduced life of the component.

If alternative lubricants are to be used, it is recommended that the factory fill be thoroughly removed before switching to any alternative lubricant.

SYNTHETIC LUBRICANTS

Synthetic lubricants may be used in John Deere equipment if they meet the applicable performance requirements (industry classification and/or military specification) as shown in this manual.

The recommended air temperature limits and service or lubricant change intervals should be maintained as shown in the operator's manual.

Avoid mixing different brands, grades, or types of oil. Oil manufacturers blend additives in their oils to meet certain specifications and performance requirements. Mixing different oils can interfere with the proper functioning of these additives and degrade lubricant performance.

LUBRICANT STORAGE

All machines operate at top efficiency only when clean lubricants are used. Use clean storage containers to handle all lubricants. Store them in an area protected from dust, moisture, and other contamination. Store drums on their sides. Make sure all containers are properly marked as to their contents. Dispose of all old, used containers and their contents properly.

MIXING OF LUBRICANTS

In general, avoid mixing different brands or types of lubricants. Manufacturers blend additives in their lubricants to meet certain specifications and performance requirements. Mixing different lubricants can interfere with the proper functioning of these additives and lubricant properties which will downgrade their intended specified performance.

SERIAL NUMBER LOCATION

When ordering parts or submitting a warranty claim, it is **IMPORTANT** that the machine product identification and component serial numbers are included.

The location of the machine identification number and component serial numbers are shown.



MACHINE IDENTIFICATION NUMBER

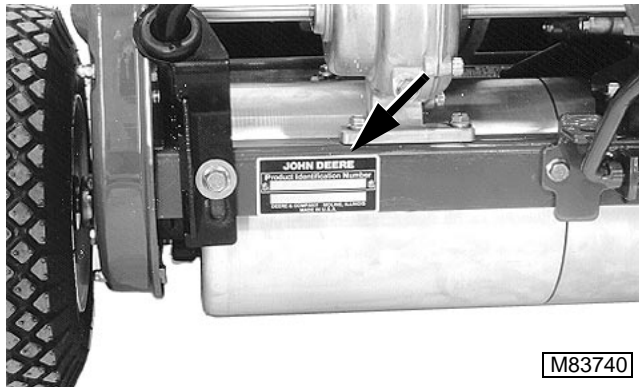

ENGINE SERIAL NUMBER

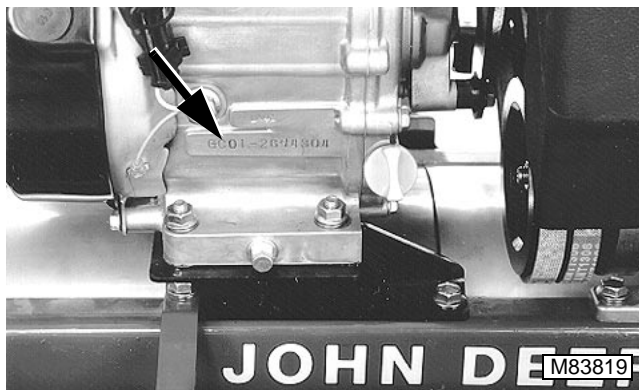

CARBURETOR IDENTIFICATION NUMBER

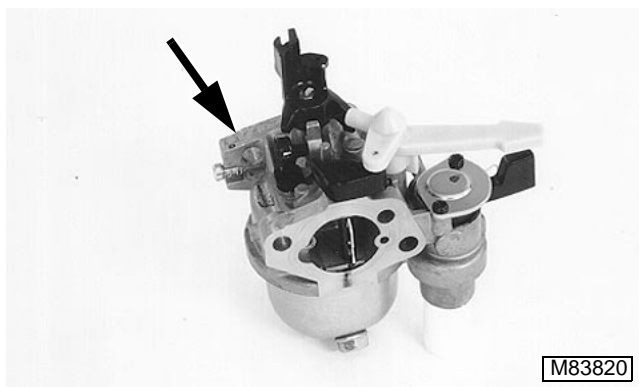

OPERATIONAL CHECKOUT PROCEDURES

The procedures covered in this group are used to give a quick checkout of all the systems and components on the unit. These checkouts should be run to insure proper operation after any extended storage, when the unit comes in for service and after repairs have been made on the unit. They can also be helpful in determining the value of the unit at trade-in time. The unit should be placed on a level surface to run checkout. All checkouts should be done and all the steps of each checkout should be followed.

Each checkout list:

- Conditions—How the unit should be set up for the checkout.
- Procedure—The specific action to be done.
- Normal—What should happen, or be heard, or seen.
- If Not Normal—Where to go if other tests or adjustments are needed.

When performing the checkout, be sure to set your machine up to the test conditions listed and follow the sequence carefully. The "NORMAL" paragraph gives the result that should happen when performing the checkout. If the results are not normal, follow the instructions listed in the "IF NOT NORMAL" paragraph to determine the cause and repair the malfunction.

ENGINE OIL LEVEL CHECK

Conditions:

- Engine stopped.
- Machine parked on level surface.
- RUN/OFF switch in OFF position.
- Engine oil cold
- Block placed under front roller to level machine/engine

Procedure:

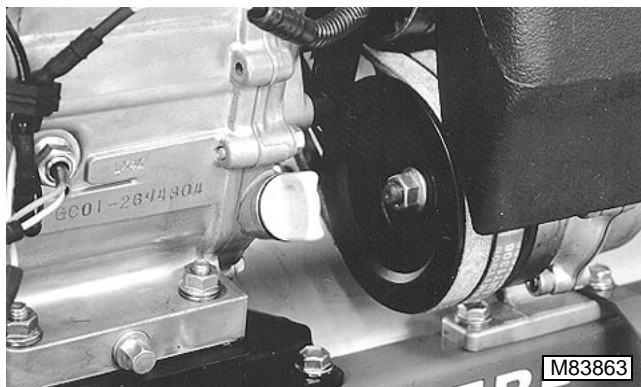

1. Before removing dipstick, clean around dipstick.
2. Remove dipstick and check oil level.

Normal:

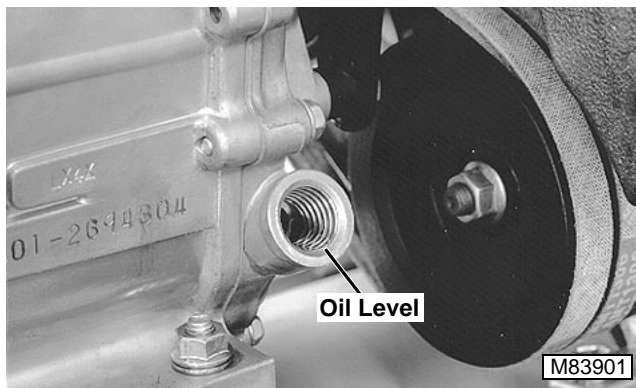

- Oil level is to the outer edge of the oil filler neck.

If Not Normal:

- Oil level is below outer edge of oil filler neck, add oil. (See 4-CYCLE GASOLINE ENGINE OIL—NORTH AMERICA on page 2-8, or 4-CYCLE GASOLINE ENGINE OIL—EUROPE on page 2-9.)

SPEED REDUCER OIL LEVEL CHECK

Conditions:

- Engine stopped.
- Machine parked on level surface.
- RUN/OFF switch in OFF position.
- Engine oil cold
- Block placed under front roller to level machine/speed reducer.

Procedure:

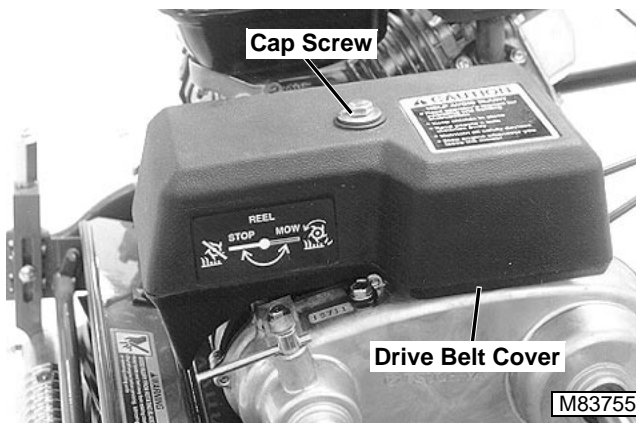

3. Remove cap screw and drive belt cover.

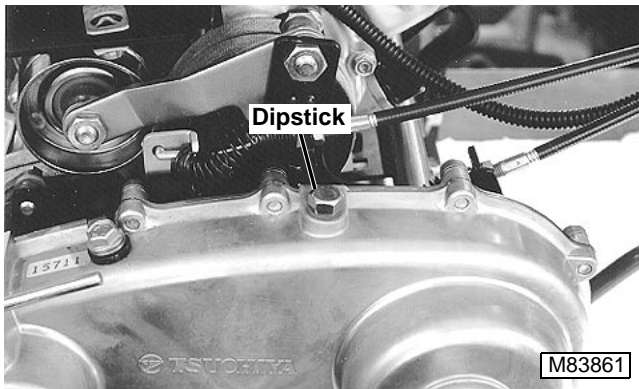

1. Before removing dipstick, clean around dipstick.
2. Wipe dipstick with a clean rag.
3. Thread dipstick into case.
4. Remove dipstick and check oil level.

Normal:

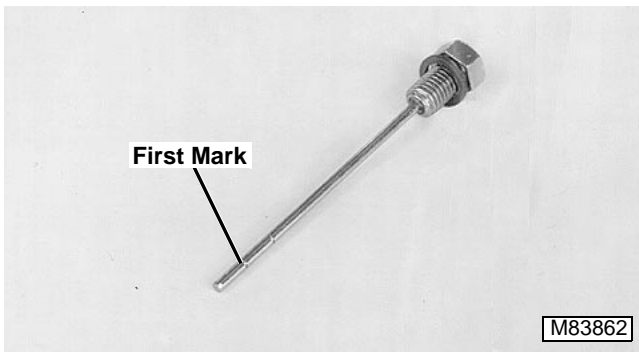

- Oil level is between bottom of dipstick and first mark.

If Not Normal:

- Oil level is below bottom of dipstick, add oil. (See SPEED REDUCER OIL—NORTH AMERICA on page 2-10, or SPEED REDUCER OIL—EUROPE on page 2-10.)
- Oil level is above first mark, drain excess oil until level is between bottom of dipstick and first mark.

THROTTLE LEVER CHECK

Conditions:

- Machine parked on level surface.
- Operator presence bail engaged.
- Travel clutch disengaged.
- Park brake engaged.



Procedure:

1. Start engine and run at slow idle (1400 +220/-150 rpm).



2. Move throttle from SLOW to FAST to SLOW positions.

Normal:

- Engine must accelerate and decelerate SMOOTHLY without hesitation.
- Throttle lever should move freely, yet hold desired position.

If Not Normal:

- Adjust throttle cable. (See THROTTLE CABLE CHECK AND ADJUSTMENT on page 3-22.)
- Adjust throttle lever tension. (See THROTTLE LEVER TENSION ADJUSTMENT on page 6-3.)

OPERATOR PRESENCE BAIL CHECK



Conditions:

- Engine running.
- Reel clutch in MOW position.
- Park brake disengaged.

Procedure:



CAUTION

Perform this check in a large, flat and open area away from people and/or stationary objects or structures.



1. Hold operator presence bail against handlebar.
2. Engage travel clutch lever.

Normal:

- Transport drive (traction roller/transport wheels) should engage.
- Reel drive should engage.

If Not Normal:

- Adjust operator presence bail. (See OPERATOR PRESENCE BAIL ADJUSTMENT on page 6-3.)
- Adjust drive belt tension. (See DRIVE BELT TENSION CHECK AND ADJUSTMENT on page 5-10.)
- Repair power train as necessary. (See POWER TRAIN—REPAIR.)

Procedure:

3. Release operator presence bail.

Normal:

- Transport drive (traction roller/transport wheels) should stop.
- Reel drive should stop.

If Not Normal:

- Adjust belt guide. (See BELT GUIDE ADJUSTMENT on page 5-11.)

PARK BRAKE CHECK

Conditions:

- Engine running.
- Reel clutch in OFF position.
- Travel clutch disengaged.

Procedure:



1. Move park brake lever to ENGAGED position.

Normal:

- Engine should remain running.
- Machine should not move when pushed or pulled.
- Cutting reel should not move.

If Not Normal:

- Adjust park brake. (See PARK BRAKE CHECK AND ADJUSTMENT on page 7-7.)

TRAVEL CLUTCH CHECK

Conditions:

- Engine running.
- Reel clutch in OFF position.
- Park brake disengaged.
- Operator presence bail engaged.

Procedure:



CAUTION

Perform this check in a large, flat and open area away from people and/or stationary objects or structures.



1. Engage travel clutch lever.

Normal:

- Transport drive (traction roller/transport wheels) should engage.

If Not Normal:

- Adjust drive belt tension. (See DRIVE BELT TENSION CHECK AND ADJUSTMENT on page 5-10.)
- Repair power train as necessary. (See POWER TRAIN—REPAIR.)

REEL CLUTCH CHECK

Conditions:

- Engine stopped.
- Machine parked on level surface.
- Park brake disengaged.

Procedure:



CAUTION

Perform this check in a large, flat and open area away from people and/or stationary objects or structures.



1. Place reel clutch lever in MOW position.
2. Start engine and run at slow idle (1400 +220/-150 rpm).

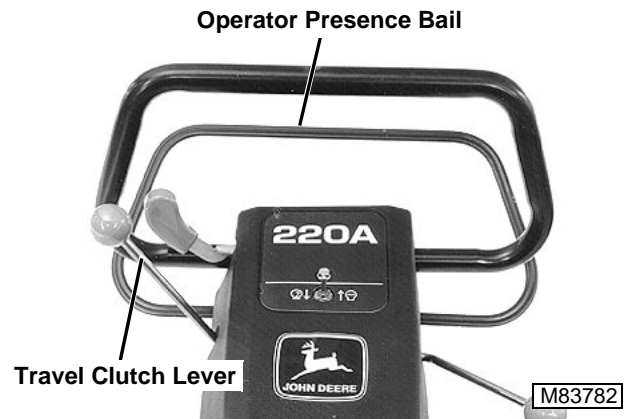

3. Hold operator presence bail against handlebar.
4. Engage travel clutch lever.

Normal:

- Transport drive (traction roller/transport wheels) should engage.
- Reel drive should engage.

If Not Normal:

- Adjust drive belt tension. (See DRIVE BELT TENSION CHECK AND ADJUSTMENT on page 5-10.)
- Repair power train as necessary. (See POWER TRAIN—REPAIR.)

Procedure:

- Release operator presence bail.



- Place reel clutch lever in MOW position.

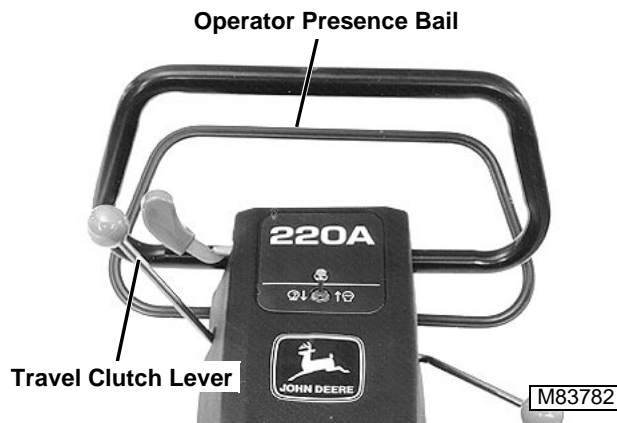

- Hold operator presence bail against handlebar.
- Engage travel clutch lever.

Normal:

- Transport drive (traction roller/transport wheels) should engage.
- Reel drive should not engage.

If Not Normal:

- Adjust drive belt tension. (See DRIVE BELT TENSION CHECK AND ADJUSTMENT on page 5-10.)
- Repair power train as necessary. (See POWER TRAIN—REPAIR.)

CONTENTS

	Page
ENGINE (HONDA GX120)	
SPECIFICATIONS	
TEST AND ADJUSTMENT SPECIFICATIONS	3-3
REPAIR SPECIFICATIONS	3-3
SPECIAL OR ESSENTIAL TOOLS	3-7
OTHER MATERIALS	3-7
SERVICE PARTS KITS	3-8
COMPONENT LOCATION AND OPERATION	
EXTERIOR ENGINE COMPONENTS	3-9
INTERNAL ENGINE COMPONENTS	3-11
LUBRICATION SYSTEM OPERATION	3-12
COOLING SYSTEM OPERATION	3-14
TROUBLESHOOTING	
ENGINE AND FUEL SYSTEM TROUBLESHOOTING CHART	3-16
ENGINE TROUBLESHOOTING GUIDE	3-18
CHECKS, TESTS AND ADJUSTMENTS	
THROTTLE CABLE CHECK AND ADJUSTMENT	3-22
SLOW IDLE SPEED ADJUSTMENT	3-22
GOVERNOR/FAST IDLE SPEED ADJUSTMENT	3-23
CYLINDER COMPRESSION TEST	3-23
VALVE CLEARANCE, CHECK AND ADJUSTMENT	3-24
SPARK TEST	3-25
SPARK PLUG GAP ADJUSTMENT	3-26
REPAIR	
FUEL TANK	3-27
FUEL FILTER	3-27
THROTTLE CABLE	3-28
MUFFLER	3-28
ENGINE	3-29
AIR CLEANER ASSEMBLY	
Removal/Installation	3-30
Service	3-31
THROTTLE PLATE ASSEMBLY	3-32
CARBURETOR	
Removal/Installation	3-32
Disassembly/Assembly	3-34
Clean/Inspect/Rebuild	3-35
Pilot Screw and Limiter Cap Replacement	3-35
Float Level Adjustment	3-36
BLOWER HOUSING	3-36
RECOIL STARTER	
Removal/Installation	3-37
Disassembly/Inspection	3-37
Assembly	3-38



	Page
REPAIR (Continued)	
IGNITION COIL	
Removal/Installation	3-39
Air Gap Adjustment	3-39
Test	3-40
FLYWHEEL	3-40
ROCKER ARM COVER	3-41
CYLINDER HEAD AND VALVES	
Removal/Installation	3-41
Disassembly/Assembly	3-42
Inspection	3-43
Valve Guide Replacement	3-44
ANALYZE VALVES	3-45
RECONDITION VALVE SEATS	3-46
LAP VALVES	3-47
REDUCTION ASSEMBLY	
Removal/Installation	3-47
Bearing/Oil Seal Replacement	3-48
CRANKCASE COVER	
Removal/Installation	3-48
Bearing/Inspection Replacement	3-49
CAMSHAFT AND TAPPETS	
Removal/Installation	3-49
Inspection	3-50
PISTON AND CONNECTING ROD	
Removal	3-50
Installation	3-51
Disassembly	3-51
Assembly	3-52
Inspection	3-53
Check Connecting Rod Side Play	3-55
Check Connecting Rod-to-Crankshaft Clearance	3-55
Check Piston Ring End Gap	3-55
ANALYZE PISTON RING WEAR	3-55
ANALYZE PISTON WEAR	3-57
CRANKSHAFT	
Removal/Installation	3-58
Inspection	3-58
Timing/Governor Drive Gear Replacement	3-58
ANALYZE CRANKSHAFT AND CONNECTING ROD WEAR	3-59
CYLINDER BLOCK	
Inspection	3-59
Bearing Inspection/Replacement	3-60
Oil Seal Replacement	3-60
Deglaze Cylinder Bore	3-60
Rebore Cylinder Bore	3-60
GOVERNOR	3-61



SPECIFICATIONS

TEST AND ADJUSTMENT SPECIFICATIONS

Fast Idle	3450 ±150 rpm
Slow Idle	1400 +200/-150 rpm
Cylinder Compression.....	586—834 kPa (85—121 psi)
Valve Clearance	
Intake	0.15 ±0.02 mm (0.006 ±0.001 in.)
Exhaust.....	0.20 ±0.02 mm (0.008 ±0.001 in.)
Pivot Lock Nut Torque.....	10 N•m (7 lb-ft)
Spark Plug Gap.....	0.7—0.8 mm (0.028—0.031 in.)



REPAIR SPECIFICATIONS

Engine

Engine Oil Capacity.....	0.6 L (0.63 qt)
Oil Drain Plug Torque	18 N•m (13 lb-ft)

Fuel Tank

Capacity	2.5 L (0.66 gal)
Cap Screw Mounting Torque.....	10 N•m (7 lb-ft)
Flange Nut Mounting Torque.....	10 N•m (7 lb-ft)
Fuel Filter Torque	2 N•m (1.4 lb-ft)

Muffler

Mounting Nut Torque.....	24 N•m (17 lb-ft)
--------------------------	-------------------

Air Cleaner Assembly

Air Cleaner Wing Nut Torque.....	9 N•m (6.5 lb-ft)
Mounting Nut Torque.....	8.5 N•m (6.1 lb-ft)

Carburetor

Float Height.....	13.7 mm (0.54 in.)
Sediment Cup Torque	4 N•m (3 lb-ft)

Ignition Coil

Air Gap	0.4 ±0.2 mm (0.016 ±0.008 in.)
Resistance (Primary Side)	0.8—1.0 ohm
Resistance (Secondary Side)	5.9—7.1 K ohm

Flywheel

Flange Nut Torque.....	75 N•m (54 lb-ft)
------------------------	-------------------

REPAIR SPECIFICATIONS, continued

Cylinder Head

Cap Screw Torque in Sequence	
Initial Torque	12 N•m (8.5 lb-ft)
Final Torque	24 N•m (17 lb-ft)
Maximum Cylinder Head Distortion	0.10 mm (0.004 in.)
Rocker Arm	
Pivot Bolt Torque	24 N•m (17 lb-ft)
Pivot Lock Nut Torque	10 N•m (7 lb-ft)
Valve Guide	
Standard ID.	5.50 mm (0.217 in.)
Wear Limit.	5.572 mm (0.2194 in.)
Valve Seats:	
Standard Width	0.8 mm (0.03 in.)
Wear Limit.	2.0 mm (0.08 in.)

Valve Spring

Free Length	
Standard	30.5 mm (1.20 in.)
Wear Limit.	29.5 mm (1.16 in.)

Intake Valve

Stem O.D.	
Standard	5.48 mm (0.216 in.)
Wear Limit.	5.318 mm (0.2094 in.)
Maximum Valve Stem Bend	
Head Diameter	22 mm (0.87 in.)

Exhaust Valve

Stem O.D.	
Standard	5.44 mm (0.214 in.)
Wear Limit.	5.275 mm (0.2077 in.)
Maximum Valve Stem Bend	
Head Diameter	19 mm (0.75 in.)

Crankcase Cover

Cap Screw Torque	12 N•m (9 lb-ft)
Camshaft Holder I.D.	
Standard	14.0 mm (0.55 in.)
Wear Limit.	14.048 mm (0.5531 in.)



REPAIR SPECIFICATIONS, continued

Piston

Connecting Rod Cap Screw Torque	12 N•m (9 lb-ft)
Piston Skirt O.D.—Standard Piston	
Standard	59.985 mm (2.3616 in.)
Wear Limit	59.845 mm (2.3561 in.)
Piston Skirt O.D.—0.25 mm (0.010 in.) Oversize Piston	
Standard	60.235 mm (2.3716 in.)
Wear Limit	60.095 mm (2.3661 in.)
Piston Skirt O.D.—0.50 mm (0.020 in.) Oversize Piston	
Standard	60.485 mm (2.38 in.)
Wear Limit	60.345 mm (2.3761 in.)
Piston-to-Cylinder Clearance	
Standard	0.015—0.050 mm (0.0006—0.0020 in.)
Wear Limit	0.12 mm (0.005 in.)
Piston Ring Thickness—1st and 2nd Compression	
Standard	1.5 mm (0.06 in.)
Wear Limit	1.37 mm (0.054 in.)
Piston Ring Thickness—Oil Control	
Standard	2.5 mm (0.10 in.)
Wear Limit	2.37 mm (0.093 in.)
Piston Ring Groove Side Clearance	
Standard	0.015—0.045 mm (0.0006—0.0018 in.)
Wear Limit	0.15 mm (0.006 in.)
Piston Ring End Gap—Top and Second	
Standard	0.2—0.4 mm (0.008—0.016 in.)
Wear Limit	1.0 mm (0.04 in.)
Piston Ring End Gap—Oil Control	
Standard	0.15—0.35 mm (0.006—0.014 in.)
Wear Limit	1.0 mm (0.04 in.)
Piston Pin O.D.	
Standard	13.0 mm (0.51 in.)
Wear Limit	12.954 mm (0.510 in.)
Piston Pin Bore I.D.	
Standard	13.002 mm (0.5119 in.)
Wear Limit	13.048 mm (0.5137 in.)
Piston-to-Piston Pin Bore Clearance	
Standard	0.002—0.014 mm (0.0001—0.0006 in.)
Wear Limit	0.08 mm (0.003 in.)



REPAIR SPECIFICATIONS, continued

Connecting Rod

Piston Pin Bushing I.D.

Standard 13.005 mm (0.512 in.)
 Wear Limit. 13.07 mm (0.515 in.)

Crankshaft Bearing I.D.—Standard Crankshaft

Standard 26.02 mm (1.024 in.)
 Wear Limit. 26.066 mm (1.0262 in.)

Crankshaft Bearing I.D.—0.25 mm (0.010 in.) Undersize Crankshaft

Standard 25.770—25.783 mm (1.0146—1.0151 in.)
 Wear Limit. 25.816 mm (1.0164 in.)

Connecting Rod-to-Crankshaft Journal Clearance

Standard 0.040—0.063 mm (0.0016—0.0025 in.)
 Wear Limit. 0.12 mm (0.005 in.)

Connecting Rod-to-Crankshaft Side Clearance

Standard 0.1—0.7 mm (0.004—0.028 in.)
 Wear Limit. 1.1 mm (0.043 in.)

Camshaft

Cam Lobe Height—Intake

Standard 27.7 mm (1.09 in.)
 Wear Limit. 27.45 mm (1.081 in.)

Cam Lobe Height—Exhaust

Standard 27.75 mm (1.093 in.)
 Wear Limit. 27.50 mm (1.083 in.)

Journal O.D.

Standard 13.984 mm (0.5506 in.)
 Wear Limit. 13.916 mm (0.5479 in.)

Crankshaft

Connecting Rod Journal O.D.

Standard 25.98 mm (1.023 in.)
 Wear Limit. 25.92 mm (1.020 in.)

Cylinder Block

Cylinder Bore I.D.— Standard Piston

Standard 60.0 mm (2.36 in.)
 Wear Limit. 60.165 mm (2.3687 in.)

Cylinder Bore I.D.— 0.25 mm (0.010 in.) Oversize Piston

Standard 60.25 mm (2.37 in.)
 Wear Limit. 60.415 mm (2.3787 in.)

Cylinder Bore I.D.—0.50 mm (0.020 in.) Oversize Piston

Standard 60.5 mm (2.41 in.)
 Wear Limit. 60.665 mm (2.3887 in.)



SPECIAL OR ESSENTIAL TOOLS

NOTE: Order tools according to information given in the U.S. SERVICEGARD™ Catalog or in the European Microfiche Tool Catalog (MTC).

JT07270 Digital Pulse Tachometer
Used to check/adjust engine slow and fast idle rpm.

JDM-59 Compression Gauge
Used to check engine compression.

D-05351ST Spark Tester
Used to check overall condition of ignition system.

JDG504 Valve Guide Driver Tool
Used to replace valve guide bushings.

JDG1023 5.5 mm Valve Guide Reamer
Used to ream valve guide bushings.



OTHER MATERIALS

Number	Name	Use
M79292	MPG-2 [®] Polymer Multipurpose Grease	Prevents parts from seizing. Apply to engine crankshaft.
	SCOTCH-BRITE [®] Abrasive Sheet/Pad	Clean cylinder head.
	Stanisol (or Kerosene)	Finish ream valve guides.
	Prussian Blue Compound	Check valve seat contact.
	Lapping compound	Lap valves into valve seats.
	Lithium Base Grease	Pack oil seals.
	Zinc Oxide/Wood Alcohol	Check block for cracks.
	Plastigauge [®]	Used to check connecting rod-to-crankshaft clearance.

Plastigauge[®] is a registered trademark of DANA corporation.

SCOTCH-BRITE[®] is a registered trademark of 3M Co.

SERVICE PARTS KITS

The following kits are available through your parts catalog:

- Carburetor Assembly
- Carburetor Float Valve Kit
- Carburetor Float Kit
- Carburetor Drain Screw Kit
- Carburetor Float Chamber Screw Kit
- Carburetor Float Chamber Kit
- Carburetor Pilot Screw and Limiter Cap Kit
- Carburetor Pilot Jet Kit
- Carburetor Gasket Kit
- Engine Gasket Kit
- Piston Ring Kit (Standard)
- Piston Ring Kit (0.25 mm [0.010 in. oversize])
- Piston Ring Kit (0.50 mm [0.020 in. oversize])
- Piston (0.25 mm [0.010 in. oversize])
- Piston (0.50 mm [0.020 in. oversize])
- Connecting Rod (Standard)
- Connecting Rod (0.25 mm [0.010 in.] undersize)
- Governor Kit
- Cylinder Block



COMPONENT LOCATION AND OPERATION

EXTERNAL ENGINE COMPONENTS

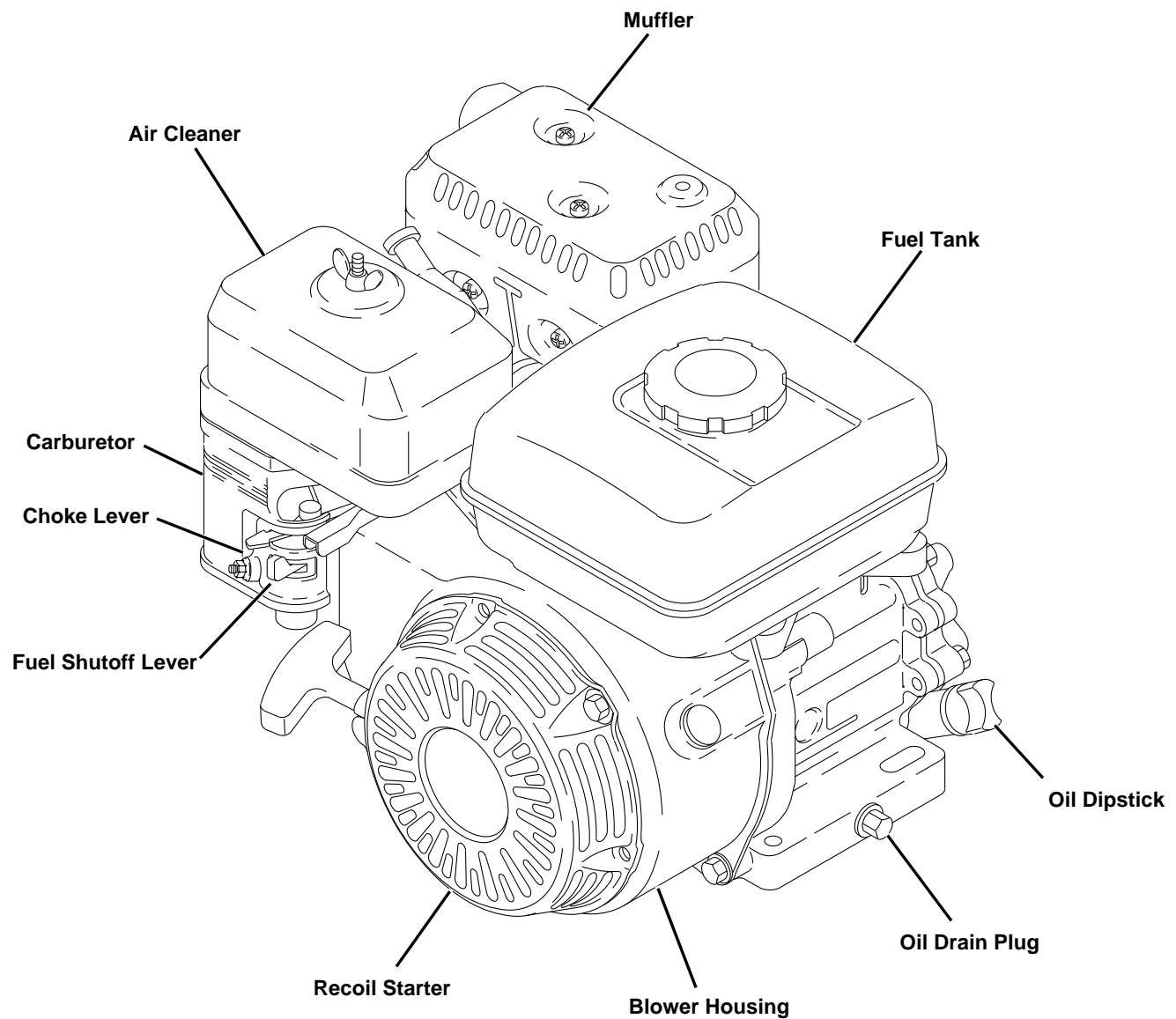

M83756

EXTERNAL ENGINE COMPONENTS, continued

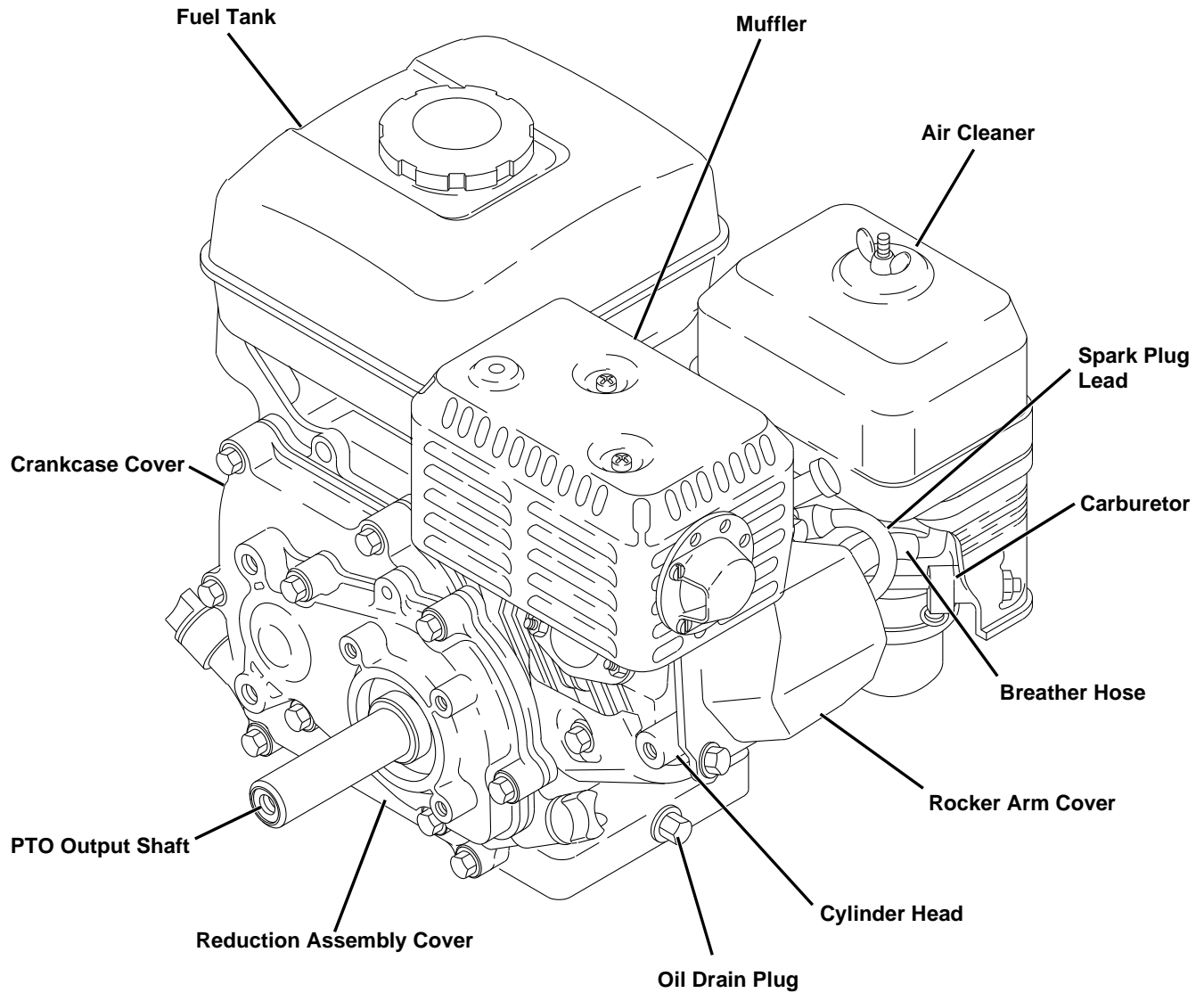

M83757

INTERNAL ENGINE COMPONENTS

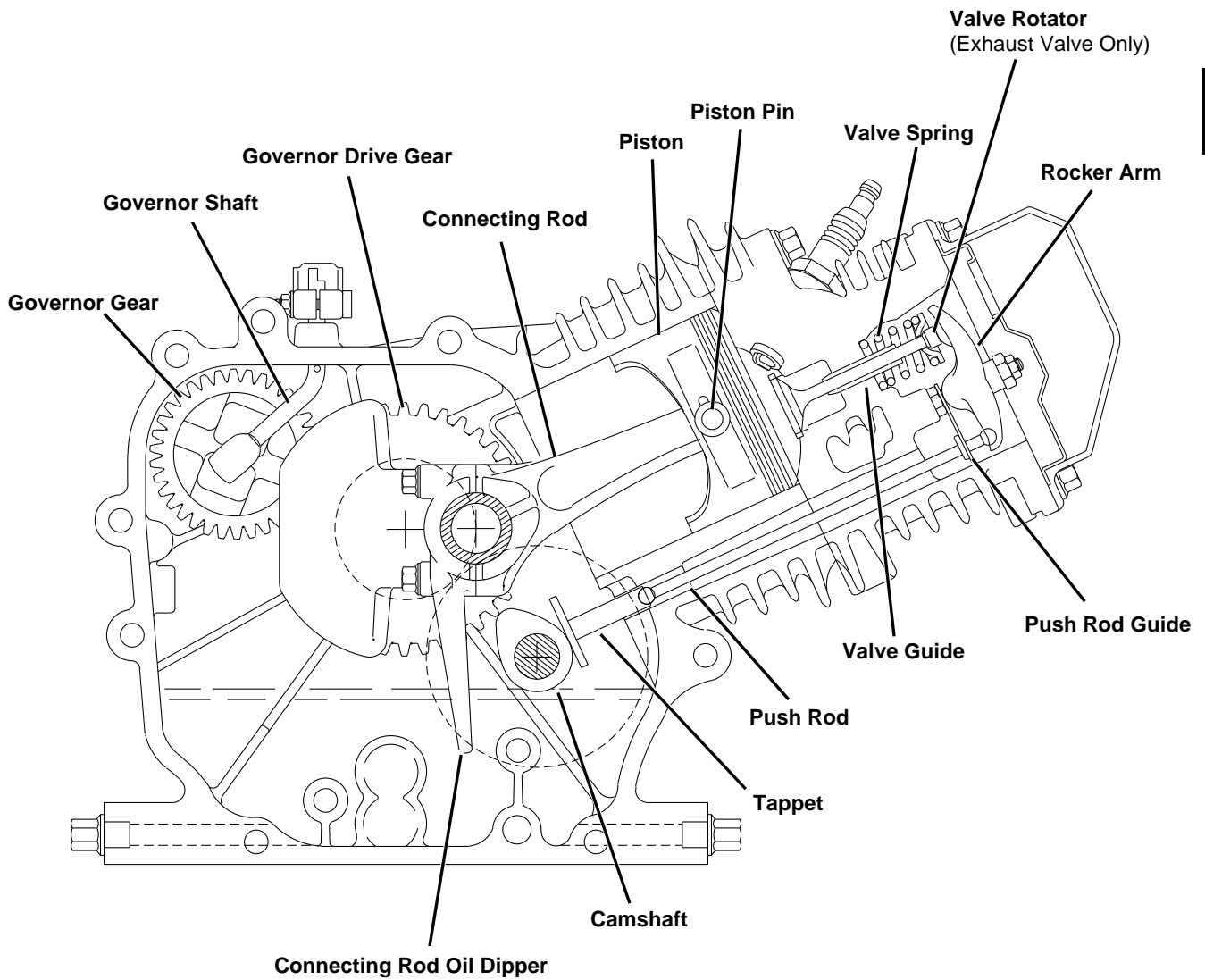

M83928

LUBRICATION SYSTEM OPERATION

Function:

To provide oil to lubricate internal engine components.

Theory of Operation:

The Honda GX120 uses a “Splash” lubrication system, and does not use an oil pump.

As the crankshaft turns, a dipper located on the connecting rod cap is immersed into the oil supply in the crankcase and “splashes” oil onto internal engine components including camshaft lobes, cylinder walls, tappets, piston pin and crankshaft ball bearings.

Oil for the connecting rod journal is supplied by a small passage on the underside of the connecting rod. Oil for the camshaft and PTO shaft journals are collected in “wells” located on the top of holders in the cylinder block and crankcase covers and routed to the journals by small passages.

Oil is supplied to the rocker arms, valves and pushrods by a passage in the cylinder block and head. Oil returns to the crankcase through a passage located between the tappets.

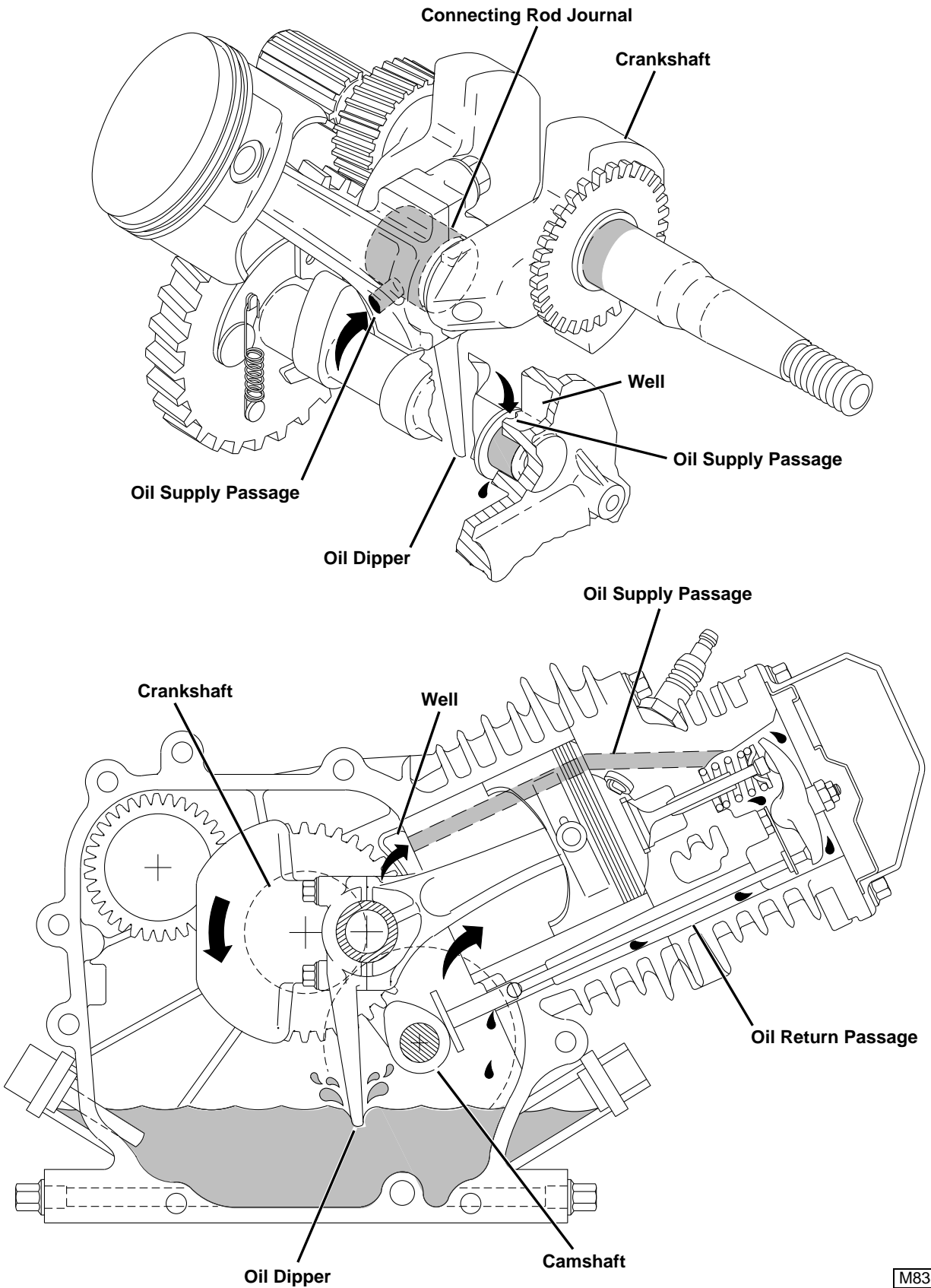

M83837

COOLING SYSTEM OPERATION

Function:

To remove heat from the engine.

Theory of Operation:

The engine is air-cooled with air flow provided by a fan mounted on the flywheel. When the engine is running, the fan draws air through the openings in the recoil starter cover. The blower housings then direct the air flow past the cooling fin on the cylinder head and block. Most of the cooling air flows directly over the valve area. This increased cooling capacity in the valve area helps to minimize valve sticking and seat wear due to overheating. The cooling fins are cast into the engine block and cylinder head to increase their surface area to allow more of the heat generated by the engine to be transferred to the cooling air.

It is important that the intake openings on the recoil starter and cooling fins on the cylinder block and cylinder head remain free of debris to ensure proper air flow. The engine covers should not be removed or altered, as cooling capacity will be reduced. Cylinder block and head cooling fins must remain clean to properly dissipate heat.

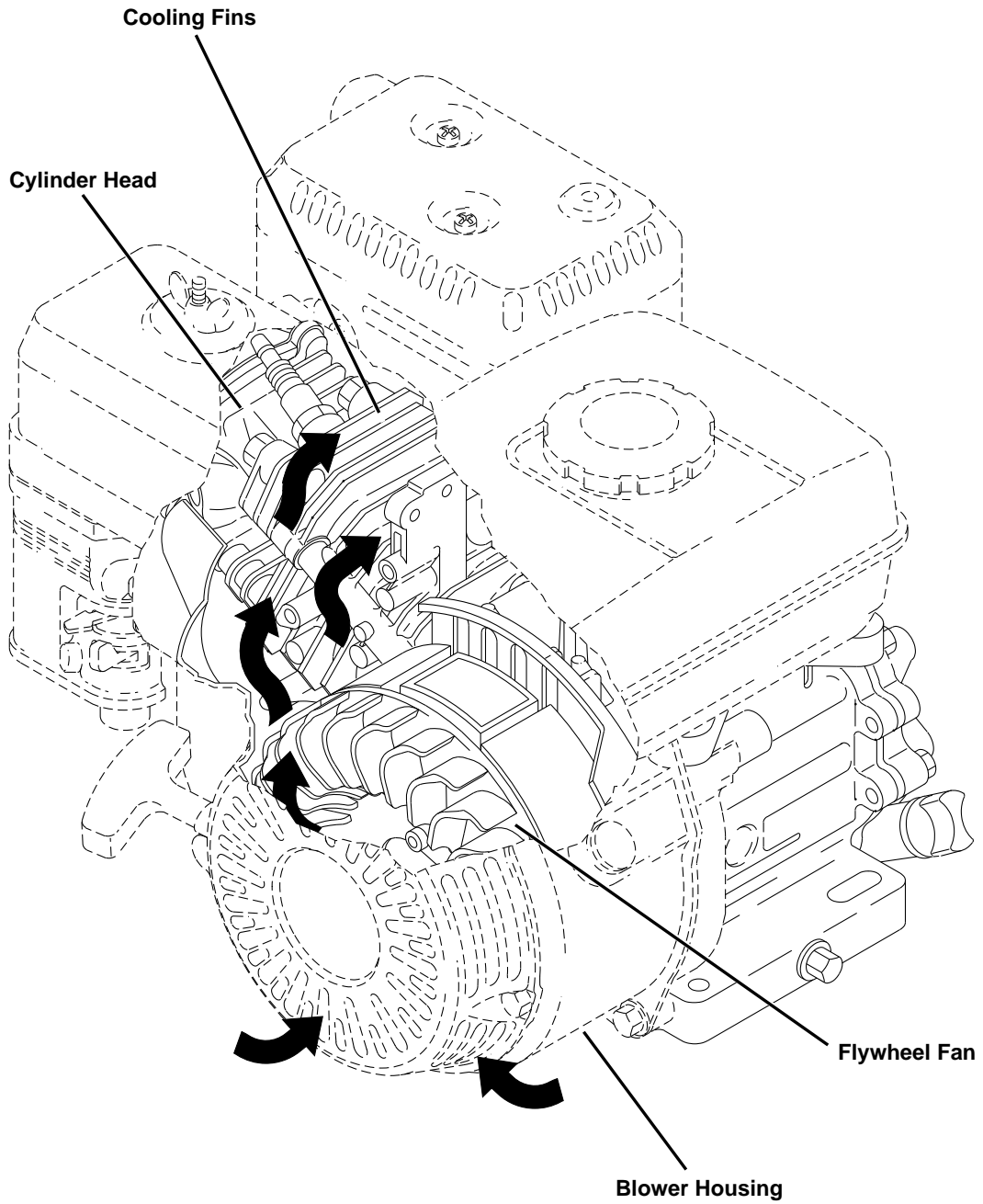

M83836

TROUBLESHOOTING

ENGINE AND FUEL SYSTEM TROUBLESHOOTING CHART

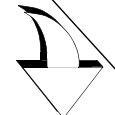

 	Engine cranks but will not start or starts hard.	Engine will not stay running, runs rough, or irregularly.	Engine stalls frequently.	Engine backfires.	Engine surges, or has uneven or uncontrolled rpm.	Engine misses.	Engine has low power.	Engine has no spark.	Lack of fuel in carburetor.	Engine floods.	Exhaust smoke black or uses too much fuel.	Exhaust smoke blue or has excessive oil consumption.	Fuel in oil.	Engine overheats.	Excessive engine noise or vibration.
Spark plug fouled, defective, or gap not correct. Incorrect spark plug.	●	●				●	●	●			●		●	●	
Defective ignition components.	●	●	●	●	●	●	●	●			●		●		
Fuel filter or line restricted. Fuel stale, contains water, or wrong type.	●	●	●	●	●	●	●		●		●	●			
Air filter element(s) plugged, oil soaked, or restricted.	●	●	●		●	●	●				●		●		
Choke, throttle, or governor linkage misadjusted. Carburetor misadjusted.	●	●	●	●	●	●	●			●	●		●		
Carburetor worn, contaminated with debris or varnish. Passages plugged. Wrong jets.	●	●	●	●	●	●	●						●		
Carburetor, intake manifold, or cylinder head gaskets leaking or damaged.	●	●	●	●	●	●	●							●	●
Low compression from worn piston, rings, cylinder, valves or warped head.	●	●	●		●	●	●					●			●
Valve clearance incorrect. Burned or warped valves and seats. Defective springs.	●	●	●	●	●	●	●								

ENGINE AND FUEL SYSTEM TROUBLESHOOTING CHART, continued

<div style="display: flex; justify-content: space-between;"> <div style="writing-mode: vertical-rl; transform: rotate(180deg);">Check Or Solution</div> <div style="text-align: center;"> Problem Or Symptom  </div> </div>	Engine cranks but will not start or starts hard.	Engine will not stay running, runs rough, or irregularly.	Engine stalls frequently.	Engine backfires.	Engine surges, or has uneven or uncontrolled rpm.	Engine misses.	Engine has low power.	Engine has no spark.	Lack of fuel in carburetor.	Engine floods.	Exhaust smoke black or uses too much fuel.	Exhaust smoke blue or has excessive oil consumption.	Fuel in oil.	Engine overheats.	Excessive engine noise or vibration.
Engine oil viscosity or level incorrect.	●						●					●		●	●
Engine gaskets or seals leaking.	●	●	●	●	●	●	●								
Crankcase breather restricted or drain hole plugged.	●	●	●		●		●					●		●	
Valve guides or seals worn or leaking. Valve stems worn.	●	●	●	●	●	●	●					●			
Worn, stuck, or broken piston rings. Cylinder bore worn. Check compression and vacuum.	●	●			●		●					●			
Connecting rod or crankshaft bearings worn. Internal wear limits out of specification.							●							●	●



ENGINE TROUBLESHOOTING GUIDE

Engine Hard to Start



Remove spark plug and check spark by cranking engine while having the plug grounded against engine block. Install spare plug to plug hole to avoid fuel spitting from the hole.

CAUTION:
To avoid electric shock, DO NOT hold plug. Make sure to hold plug cap.

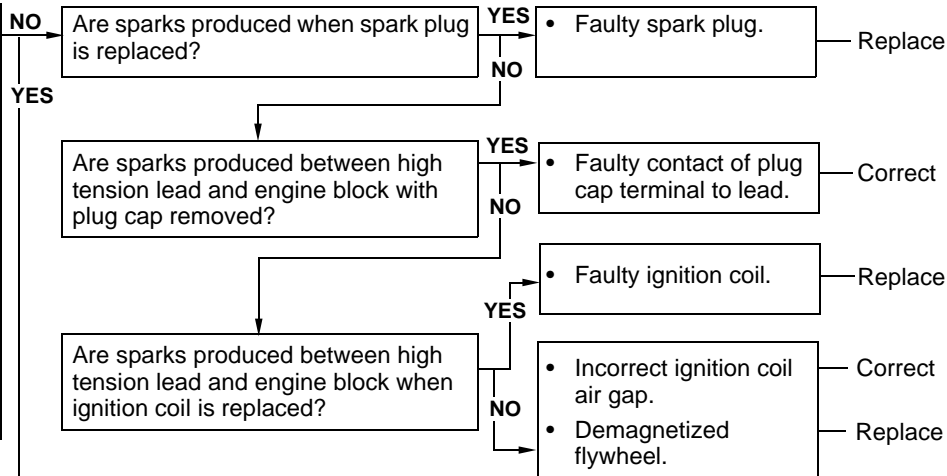

Is compression sufficient?

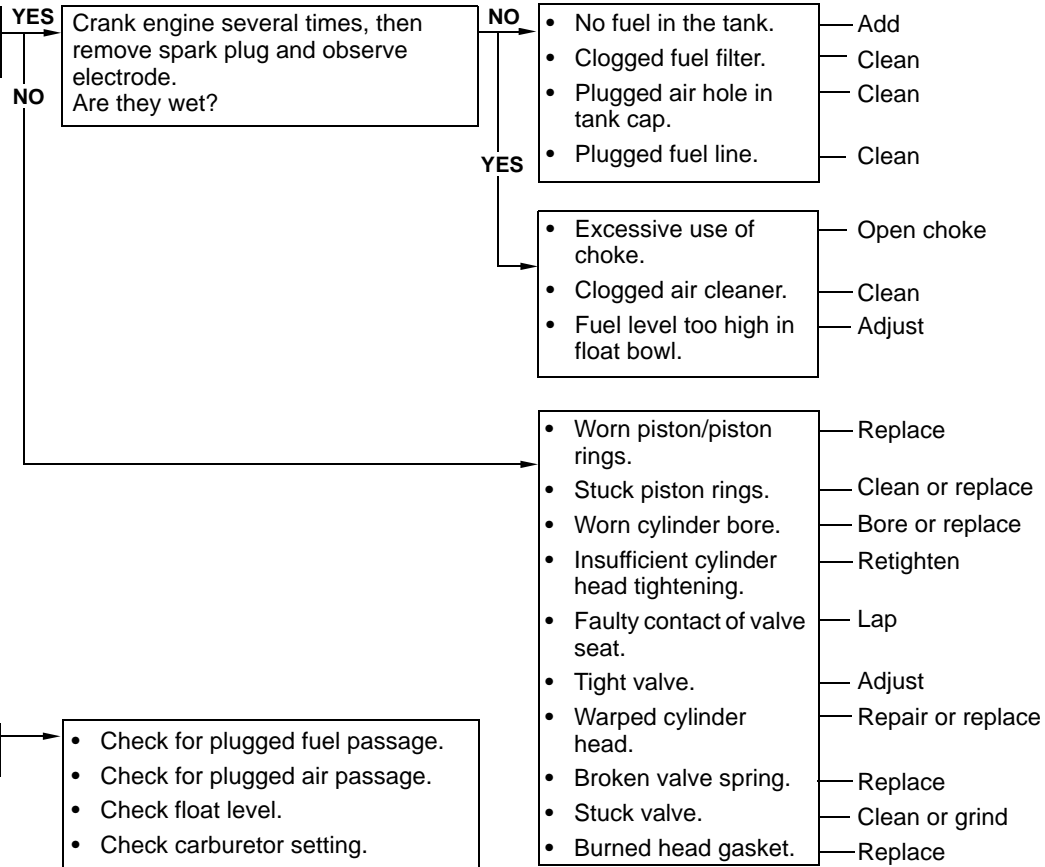

Check carburetor.

- Check for plugged fuel passage.
- Check for plugged air passage.
- Check float level.
- Check carburetor setting.

Engine Malfunctions at Low Speed

Remove spark plug and check spark by cranking engine while having the plug grounded against engine block. Install spare plug to plug hole to avoid fuel spitting from the hole.

CAUTION:
To avoid electric shock, DO NOT hold plug. Make sure to hold plug cap.

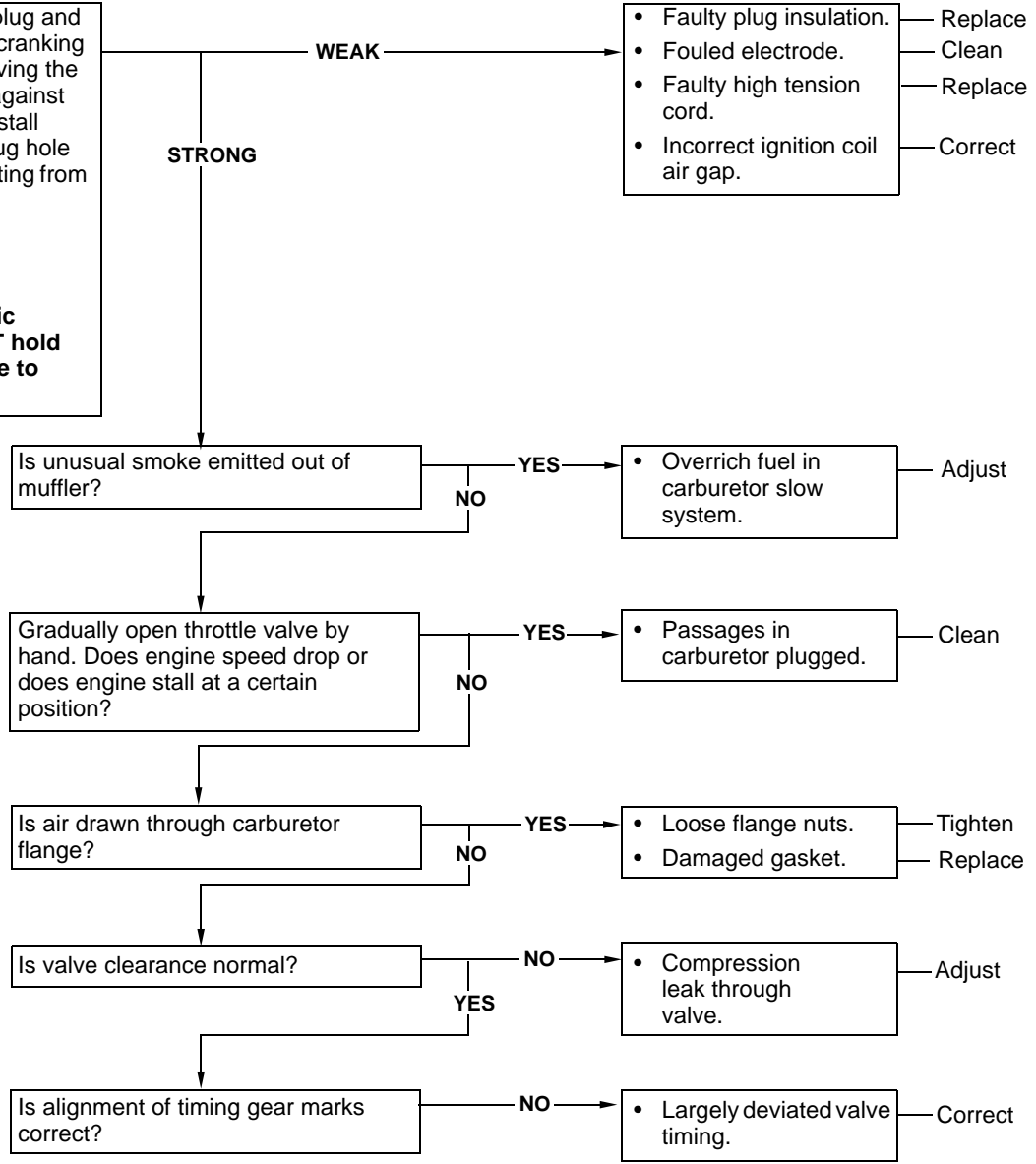

Engine Runs Erratically

Problem in fuel system (lack of fuel).

- Dust or water in fuel line or fuel filter.
- Air or vapor lock in fuel line.
- Plugged air vent in fuel tank cap.
- Plugged air/fuel passages in carburetor.
- Too little opening of carburetor pilot air-screw.

- Clean
- Remove
- Clean
- Clean
- Correct

Problem in governor system.

- Incorrect governor linkage adjustment.
- Faulty governor spring.
- Governor gear assembly malfunction.

- Correct
- Replace
- Check

Engine knocks.

- Stale fuel.
- Excessive carbon deposit in engine.
- Excessive engine load.
- Engine overheating.

- Change
- Clean
- Adjust
- See **Has Low Power**

Oil Consumption Is Excessive

Is compression sufficient?

YES
NO

- Plugged oil ring groove.
- High oil level.
- Worn valve stems and valve guides.
- Oil leakage along governor shaft.
- Oil seals leaking.
- Head gasket leaking.
- Drain plug leaking.
- Breather tube clogged.
- Drain-back hole in tappet chamber plugged.
- Incorrect oil viscosity.

- Clean
- Adjust
- Replace
- Replace
- Replace
- Replace
- Retighten or replace
- Clean
- Clean
- Change

• Same as **Hard To Start**.

Engine Has Low Power

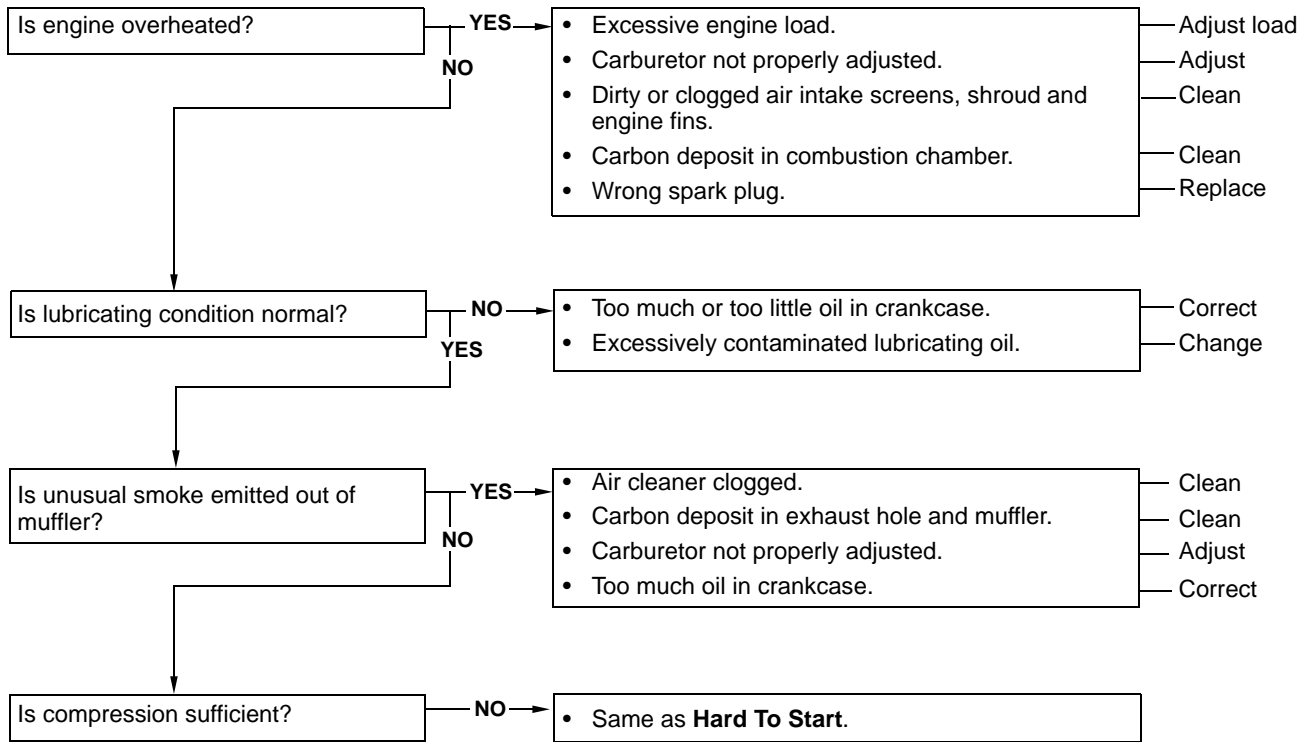

Fuel Consumption Is Excessive

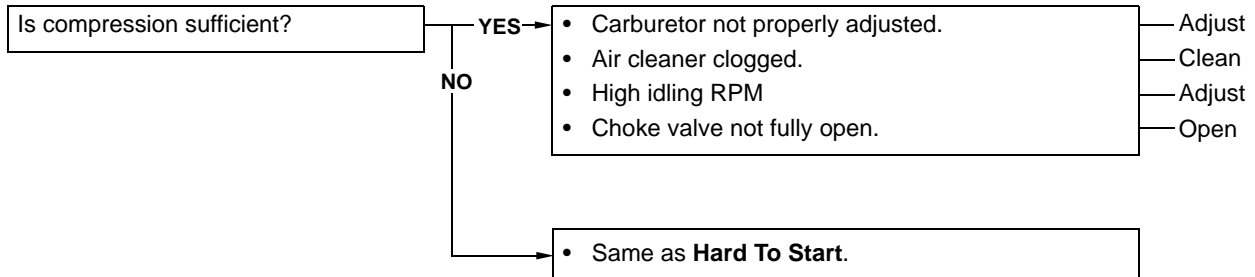

CHECKS, TESTS AND ADJUSTMENTS

THROTTLE CABLE CHECK AND ADJUSTMENT



Reason:

To make sure the throttle control lever allows full range of engine speeds.

Procedure:

1. Park machine on a level surface.
2. Move RUN/OFF switch to OFF position.
3. Move Travel Clutch Lever to NEUTRAL position.
4. Engage park brake.
5. Move throttle lever to FAST idle position.

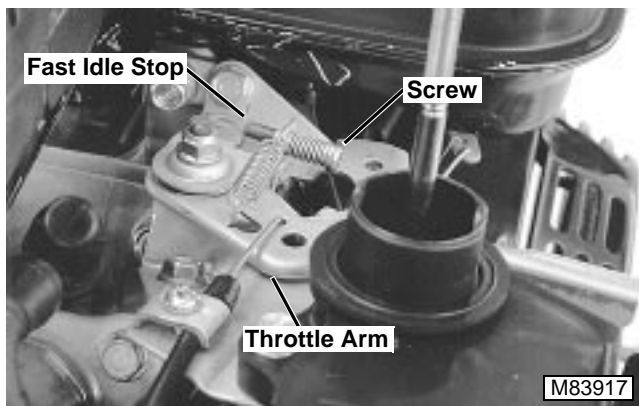

NOTE: Air cleaner removed for photo clarity only.

6. Loosen screw and move cable until throttle arm rests against fast idle stop.
7. Tighten screw.
8. Start engine and move throttle lever from SLOW to FAST to SLOW positions to verify operation.

SLOW IDLE SPEED ADJUSTMENT

ATTENTION!

DO NOT attempt to adjust the carburetor unless you are a factory trained technician with authorization to service CARB/EPA Certified Emissions Carburetors.

Reason:

To ensure that the engine is running at proper SLOW idle rpm.

Equipment:

- JT07270 Digital Pulse Tachometer

Procedure:

1. Park machine on a level surface.
2. Move RUN/OFF switch to OFF position.
3. Move Travel Clutch Lever to NEUTRAL position.
4. Engage park brake.
5. Start and run engine for five minutes to bring to operating temperature.
6. Move throttle to SLOW idle position.
7. Hold a JT07270 Digital Pulse Tachometer at spark plug lead.

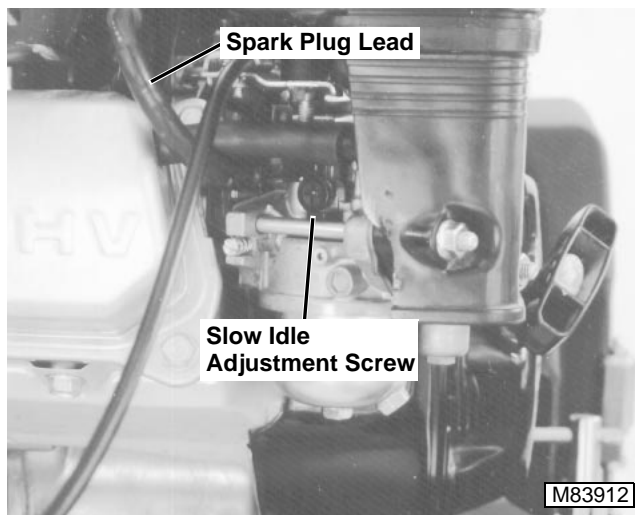

8. Adjust slow idle adjustment screw until the engine is running at a slow idle speed of **1400 +200/-150 rpm**.

GOVERNOR/FAST IDLE SPEED ADJUSTMENT

Reason:

To ensure that the engine is running at proper FAST idle rpm.

Equipment:

- JT07270 Digital Pulse Tachometer

Procedure:

1. Park machine on a level surface.
2. Move RUN/OFF switch to OFF position.
3. Move Travel Clutch Lever to NEUTRAL position.
4. Engage park brake.
5. Remove fuel tank. (See FUEL TANK—Removal/Installation on page 3-27.)

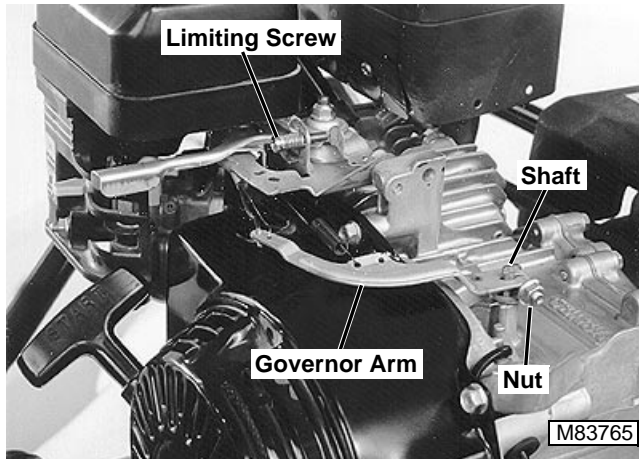

6. Loosen governor arm nut and move governor arm to allow the throttle to open fully.
7. Rotate governor shaft as far as it will go in the same direction. Tighten nut to secure arm on shaft.
8. Install fuel tank.
9. Start and run engine for five minutes to bring to operating temperature.
10. Move throttle to FAST idle position.
11. Hold a JT07270 Digital Pulse Tachometer at spark plug lead.

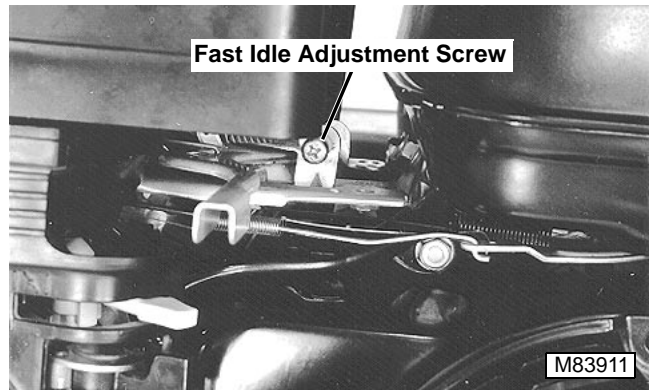

12. Adjust fast idle adjustment screw until the engine is running at a fast idle speed of 3450 ± 150 rpm.

CYLINDER COMPRESSION PRESSURE TEST

Reason:

To determine the condition of the piston, rings, cylinder walls and valves.

Equipment:

- JDM59 Compression Gauge

Procedure:



CAUTION

Engine components are HOT. Be careful not to touch, especially the muffler while making adjustments. Wear protective eye glasses and clothing.

1. Run engine for five minutes to bring to operating temperature.
2. Park machine on a level surface.
3. Move RUN/OFF switch to OFF position.
4. Move Travel Clutch Lever to NEUTRAL position.
5. Engage park brake.
6. Remove spark plug.

JDM59 Compression Gauge

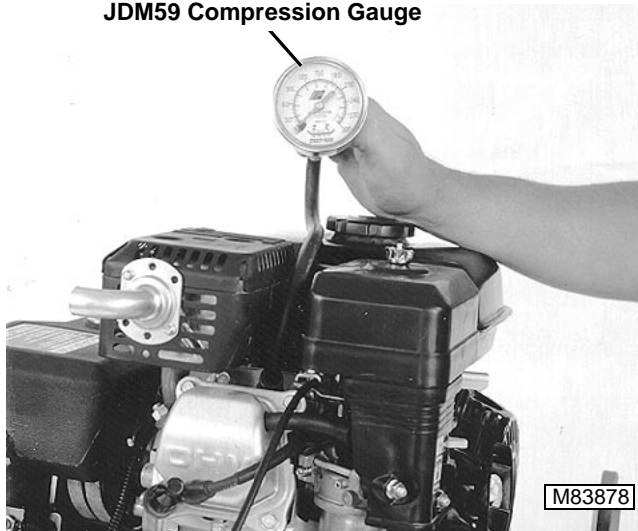

7. Install JDM59 Compression Gauge in spark plug hole.
8. Ground high tension lead.
9. Move throttle control lever to FAST idle position.
10. Pull recoil starter (full strokes) several times and record highest gauge reading. Compression should read from **586—834 kPa (85—121 psi)**.

Results:

NOTE: Specification listed is for an engine that has had sufficient time to allow rings to fully seat.

Compression that is lower than specifications on low hour machines probably does not indicate a problem.

- If above specifications, adjust valves and check fuel and air intake systems. Check exhaust for restriction.
- If below specifications, squirt clean engine oil into cylinder and repeat test (one sprint from oil can).
- If compression pressure DOES NOT increase after retest, check for leaking intake or exhaust valves, valve seats or cylinder head gasket. Replace parts as necessary.
- If compression pressure INCREASES after retest, check rings, piston and cylinder bore for broken rings, scoring, wear or damage. Replace parts as necessary.

VALVE CLEARANCE CHECK AND ADJUSTMENT

Reason:

To ensure proper opening and closing of the intake and exhaust valves.

Equipment:

- Feeler Gauge (Blade Type)

Check Procedure:

IMPORTANT: Perform adjustment when engine is cold.

1. Park machine on a level surface.
2. Move RUN/OFF switch to OFF position. Allow engine to cool.
3. Move Travel Clutch Lever to NEUTRAL position.
4. Engage park brake.
5. Remove spark plug.
6. Remove rocker arm cover. (See **ROCKER ARM COVER—Removal/Installation** on page 3-41.)

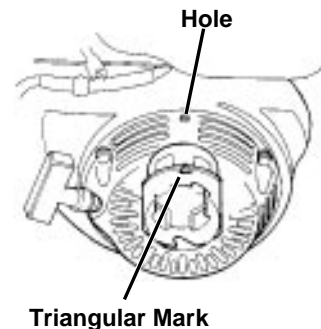

7. Slowly pull recoil starter until piston is at Top Dead Center (TDC) of compression stroke (both intake and exhaust valves will be closed). The triangular mark on the starter pulley will align with the top hole on the Top Dead Center of the compression or exhaust stroke.

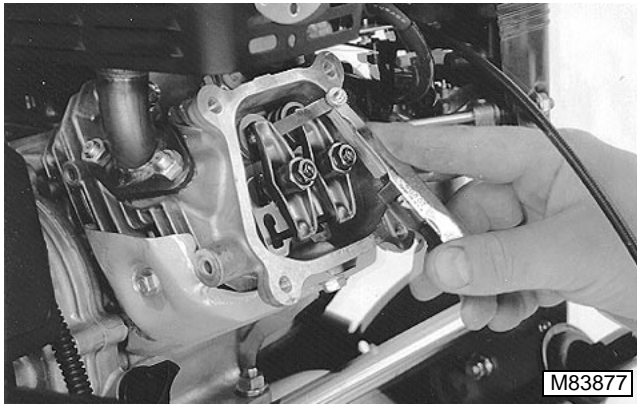

- Use a blade-type feeler gauge to measure valve clearance.

Specifications:

Intake 0.15 ±0.05 mm (0.006 ±0.001 in.)

Exhaust 0.20 mm ±0.02 mm (0.008 ±0.001 in.)

Results:

- If valve clearance does not meet the specifications, adjust as follows:

Adjustment Procedure:



- Hold rocker arm pivot and loosen rocker arm lock nut.
- Turn the rocker arm pivot to obtain specified clearance.
- Retighten rocker arm pivot lock nut to **10 N•m (7 lb-ft)** while holding the rocker arm pivot.
- Recheck clearance after tightening lock nut.

SPARK TEST

Reason:

To test the overall condition of the ignition system.

Equipment:

- D-05351ST Spark Tester

Procedure:

- Park machine on a level surface.
- Move RUN/OFF switch to OFF position.
- Move Travel Clutch Lever to NEUTRAL position.
- Engage park brake.
- Remove high tension lead from spark plug.



- Connect D-05351ST Spark Tester to spark plug.
- Connect high tension lead to Spark Tester.

IMPORTANT: DO NOT adjust spark tester gap beyond 5.0 mm (0.200 in.) (5 turns), as damage to ignition system could occur.

- Adjust Spark Tester gap to 4.2 mm (0.166 in.) (4 turns) with screw.
- Pull recoil starter (full strokes) several times and watch spark at spark tester. If engine will start, watch spark with engine running. A steady, strong, blue spark should be observed.

Results:

- If spark is weak, or no spark is present, install a new spark plug and repeat test.
- If spark is still weak, or no spark is present, run tests on individual components to find the cause of the malfunction.

SPARK PLUG GAP ADJUSTMENT

Reason:

To ensure correct spark plug gap for maximum performance.

**Equipment:**

- Feeler Gauge

Procedure:

1. Park machine on a level surface.
2. Move RUN/OFF switch to OFF position. Allow engine to cool.
3. Move Travel Clutch Lever to NEUTRAL position.
4. Engage park brake.



CAUTION

Engine components are HOT. Be careful not to touch, especially the muffler while making adjustments. Wear protective eye glasses and clothing.

5. Remove spark plug.

IMPORTANT: DO NOT clean spark plug with sand paper or abrasives. Engine scoring can result.

6. Scrape or wire brush deposits from spark plug.
7. Inspect plug for:
 - Cracked porcelain
 - Pitted or damaged electrodes



8. Check spark plug gap using a feeler gauge. Set gap to **0.7—0.8 mm (0.028—0.031 in.)**.
9. Inspect sealing washer. Replace spark plug if necessary.
10. Install plug finger-tight until washer is seated. Using a spark plug wrench, tighten plug an additional 1/2 turn if a new plug (or 1/8—1/4 turn for a used plug) to compress washer.

REPAIR

FUEL TANK

Removal/Installation

**CAUTION**

Gasoline vapor is explosive. DO NOT expose to spark or flame. Serious personal injury can result.

1. Remove air cleaner assembly. (See AIR CLEANER ASSEMBLY—Removal/Installation on page 3-30.)

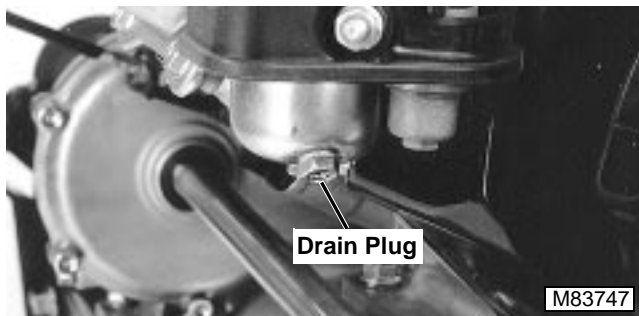

NOTE: Fuel tank capacity is approximately 2.5 L (0.66 U.S. gal).

2. Remove drain plug and drain fuel into a properly marked container.

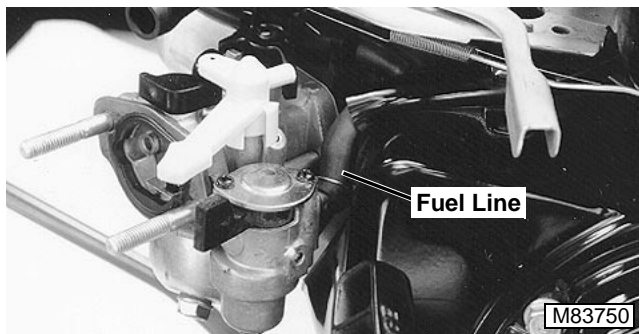

3. Disconnect fuel line at carburetor.



4. Remove cap screw.

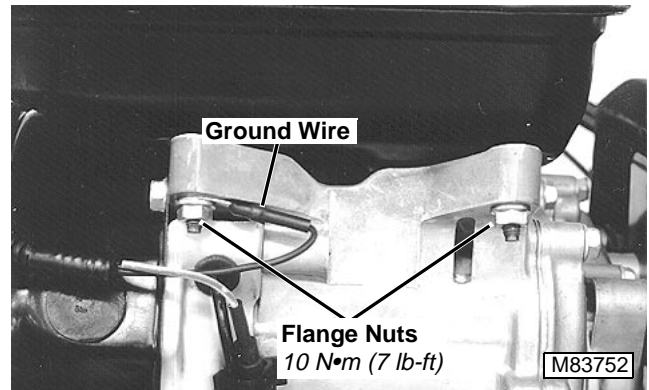

5. Remove two flange nuts and ground wire.
6. Remove fuel tank.
7. Inspect fuel tank for signs of wear or damage. Replace if necessary.
8. Inspect fuel filter. Clean and/or replace if necessary. (See Fuel Filter.)

Installation is done in the reverse order of removal.

- Attach ground wire to the fuel tank stud (recoil starter side).
- Tighten cap screw and flange nuts to **10 N•m (7 lb-ft)**.
- Inspect for leaks. Repair leaks and wipe-up spilled fuel before starting engine.

FUEL FILTER

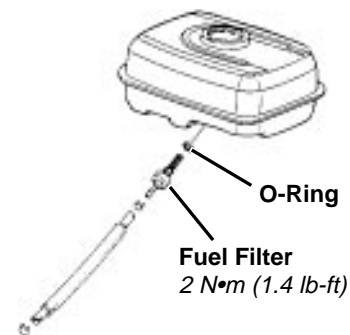

1. Remove fuel tank. (See FUEL TANK—Removal/Installation.)
2. Remove fuel line.
3. Remove fuel filter.
4. Clean and inspect fuel filter. Replace if necessary.

Installation is done in the reverse order of removal.

- Tighten fuel filter to **2 N•m (1.4 lb-ft)**.

THROTTLE CABLE

Removal/Installation

1. Remove handlebar cover. (See HANDLEBAR COVER—Removal/Installation on page 6-5.)
2. Remove air cleaner cover and element. (See AIR CLEANER ASSEMBLY—Removal/Installation on page 3-30.)

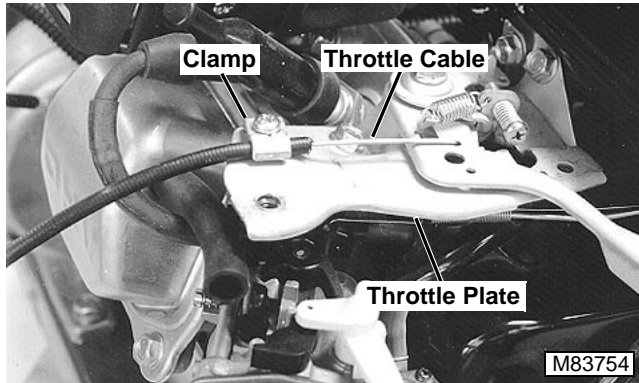

3. Loosen clamp and disconnect throttle cable at throttle plate assembly.

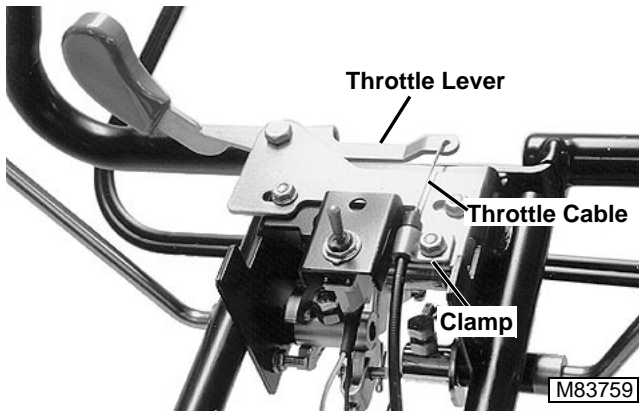

4. Loosen clamp and disconnect throttle cable at throttle lever.

Installation is done in the reverse order of removal.

- Adjust throttle cable. (See THROTTLE CABLE CHECK AND ADJUSTMENT on page 3-22.)

MUFFLER

Removal/Installation



CAUTION

To prevent possible burns, allow engine to cool before removing muffler.



1. Remove nuts and washers.
2. Remove muffler and gasket.

Installation is done in the reverse order of removal.

- Use new gasket for installation.
- Tighten mounting nuts to **24 N•m (17 lb-ft)**.

ENGINE

Removal/Installation

1. Remove air cleaner cover and element. (See AIR CLEANER ASSEMBLY—Removal/Installation on page 3-30.)

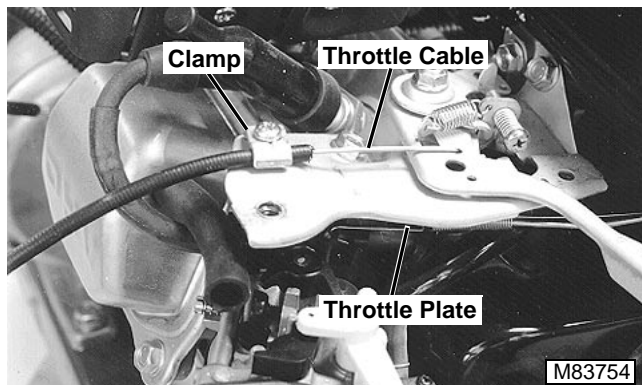

2. Loosen clamp and disconnect throttle cable at throttle plate assembly.

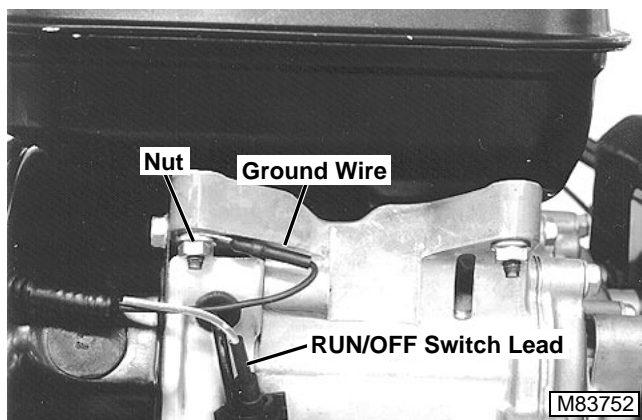

3. Remove nut and RUN/OFF switch ground wire.
4. Disconnect RUN/OFF switch wiring lead.

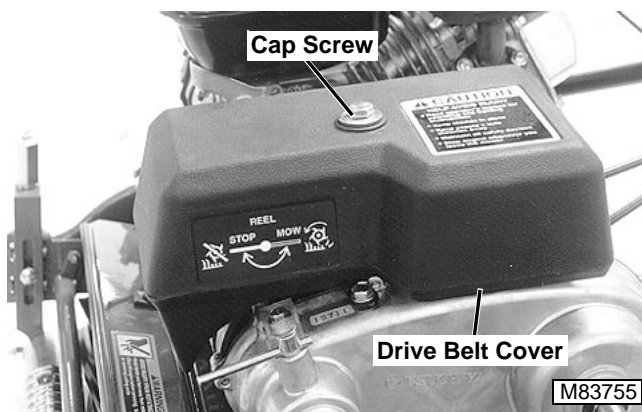

5. Remove cap screw and drive belt cover.

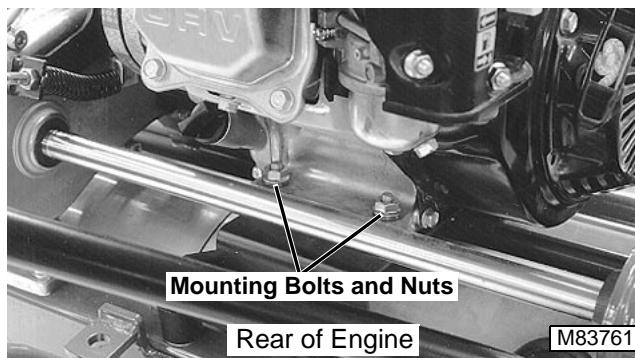
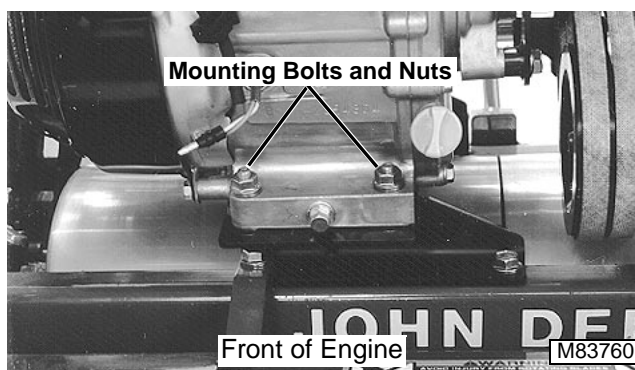

6. Remove front and rear engine mounting bolts and nuts.

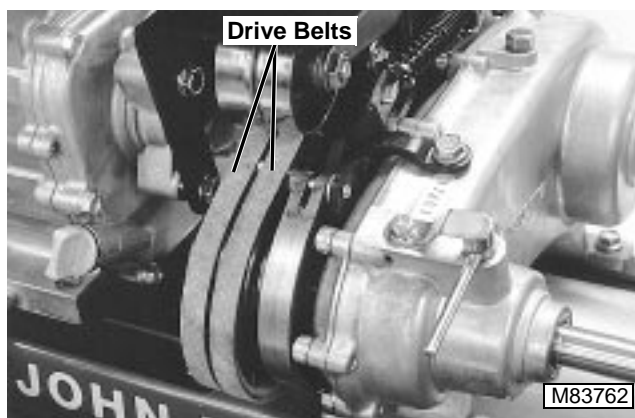

7. Slide engine forward and remove drive belts.
8. Remove engine.

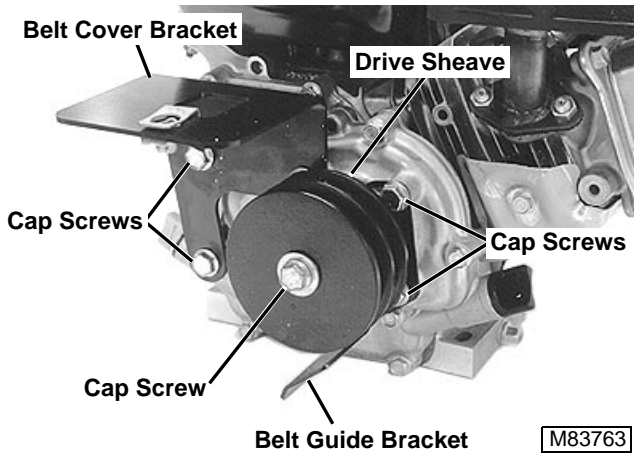

9. If engine is to be repaired, remove:
- Cap screw, washer, drive sheave and key.
 - Cap screws and belt cover bracket
 - Cap screws and brackets.

NOTE: Crankcase capacity is approximately **0.6 L (0.63 qt)**.

10. If engine is to be repaired, remove drain plug and drain crankcase.

Installation is done in the reverse order of removal.

NOTE: If the engine has been rebuilt (cylinder rebored or deglazed, etc.), the oil should be changed after the first 20 hours (maximum) of operation.

- Fill engine to proper level with oil of correct specifications. (See 4-CYCLE GASOLINE ENGINE OIL—NORTH AMERICA on page 2-8, or 4-CYCLE GASOLINE ENGINE OIL—EUROPE on page 2-9.)
- Adjust drive belt tension. (See DRIVE BELT TENSION CHECK AND ADJUSTMENT on page 5-10.)
- Adjust drive belt guide. (See DRIVE BELT GUIDE ADJUSTMENT on page 5-11.)
- Adjust throttle cable. (See THROTTLE CABLE CHECK AND ADJUSTMENT on page 3- 22.)

AIR CLEANER ASSEMBLY

Removal/Installation

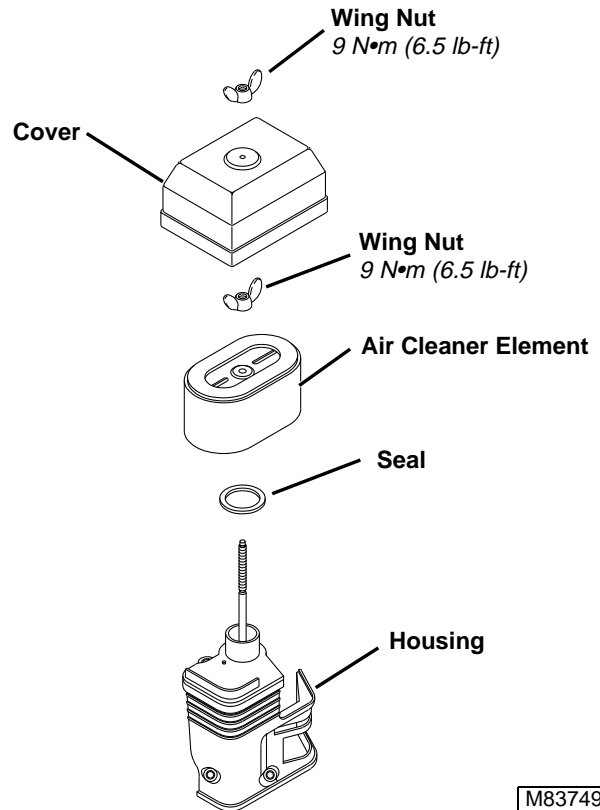

1. Remove wing nut and cover.
2. Remove wing nut and air cleaner.

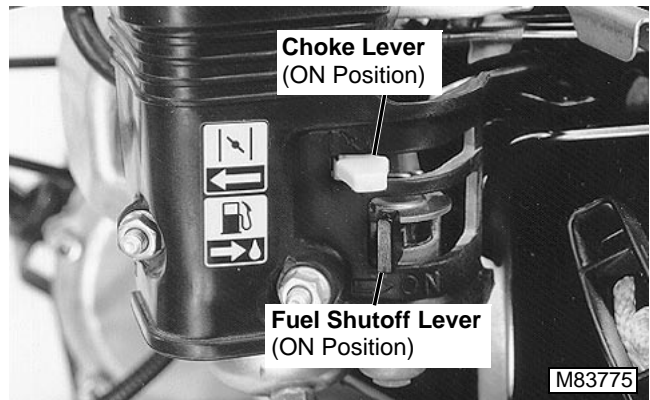

3. Move fuel shutoff valve to OFF position.
4. Move choke lever to FULL CHOKE position.

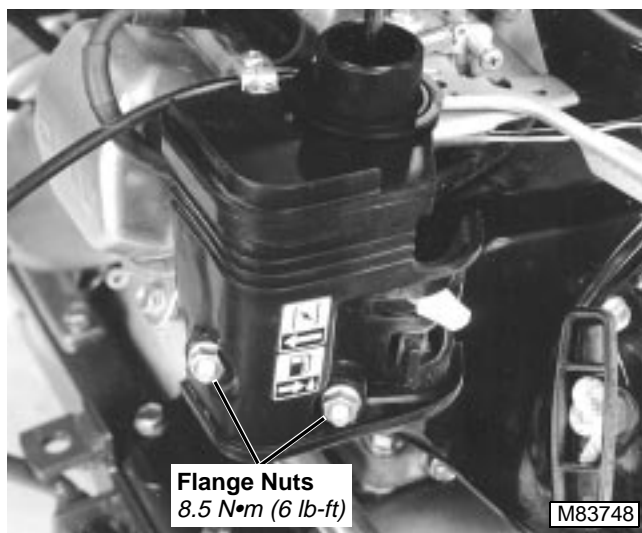

5. Remove two flange nuts.
6. Remove cap screw.
7. Remove air cleaner housing and gasket.
8. Inspect and clean air filter element. Replace if necessary. (See Service procedure.)
9. Inspect gasket for damage. Replace if necessary.

Installation is done in the reverse order of removal.

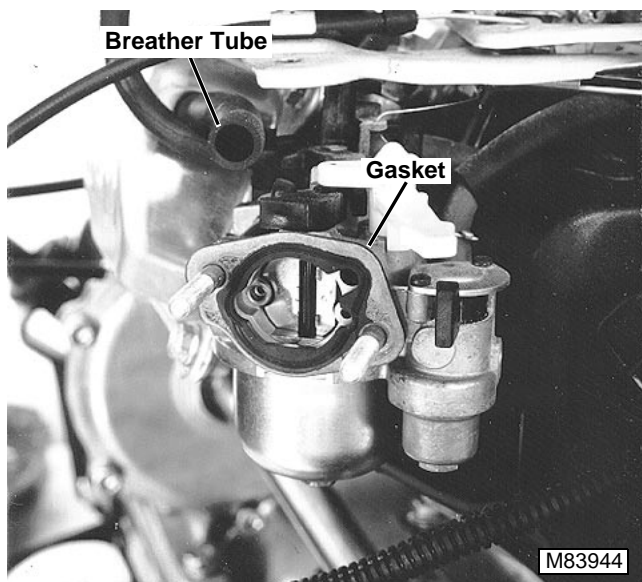

- Install gasket as shown.
- Connect breather tube to air cleaner housing.
- Tighten air cleaner element and cover wing nuts to **9 N•m (6.5 lb-ft)**.
- Tighten housing flange nuts to **8.5 N•m (6 lb-ft)**.

Service

IMPORTANT: Carefully remove air cleaner cover and elements. Inspect inside paper element and intake passage for signs of dust. If present, replace elements and test engine compression or inspect for damage.

Any time the air cleaner is removed, check for free choke plate operation during reassembly.



1. Remove air cleaner cover and element. (See AIR CLEANER ASSEMBLY—Removal/Installation on page 3-30.)

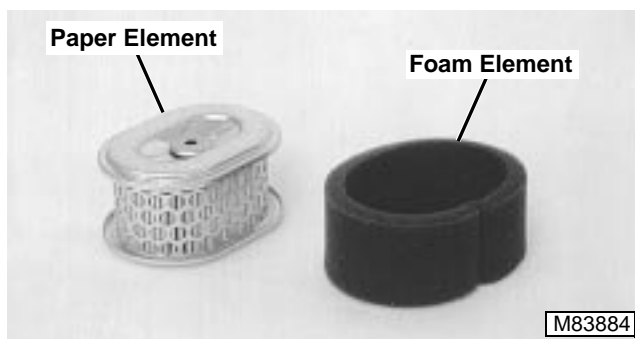

2. Remove foam element from paper element.
3. Wash foam element in warm soapy water, rinse and allow to dry thoroughly.
4. Apply 12—15 drops of clean engine oil to foam element. Squeeze out excess oil.

IMPORTANT: DO NOT clean paper element with solvent or compressed air.

5. Gently tap paper element to remove dust.
6. Inspect paper element:
 - Element is still usable if you can see light through it and element appears clean.
 - Replace element if oily, dirty or damaged in any way.
7. Inspect cover and housing for damage. Replace parts as necessary.
8. Assemble and install air cleaner assembly.

THROTTLE PLATE ASSEMBLY

Removal/Installation

1. Remove air cleaner assembly. (See AIR CLEANER ASSEMBLY—Removal/Installation on page 3-30.)

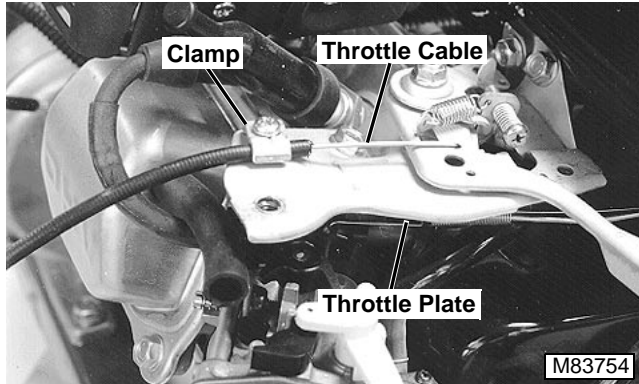

2. Loosen clamp and disconnect throttle cable at throttle plate assembly.

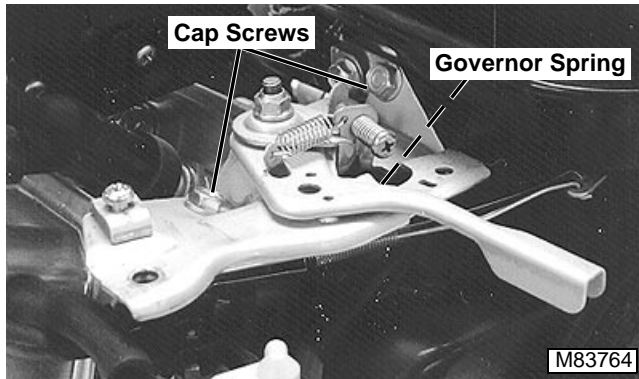

3. Disconnect governor spring.
4. Remove two cap screws.
5. Remove throttle plate assembly.

Installation is done in the reverse order of removal.

- Adjust throttle cable. (See THROTTLE CABLE CHECK AND ADJUSTMENT on page 3-22.)

CARBURETOR

Removal/Installation



CAUTION

Gasoline is extremely flammable. DO NOT smoke. Always work in a ventilated area away from open flame or spark producing equipment, this includes equipment that utilizes pilot lights.

1. Remove air cleaner assembly. (See AIR CLEANER ASSEMBLY—Removal/Installation on page 3-30.)

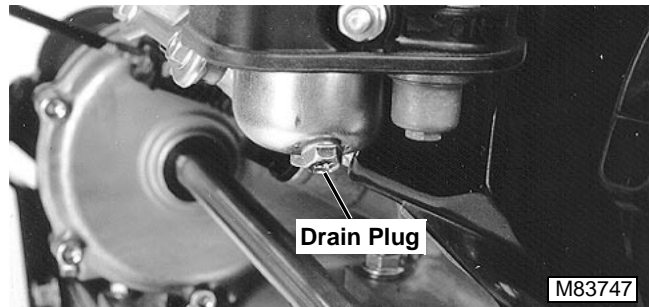

NOTE: Fuel tank capacity is approximately **3.6 L (0.95 qt)**.

2. Remove drain plug and drain fuel into a properly marked container.



3. Disconnect fuel line at carburetor.

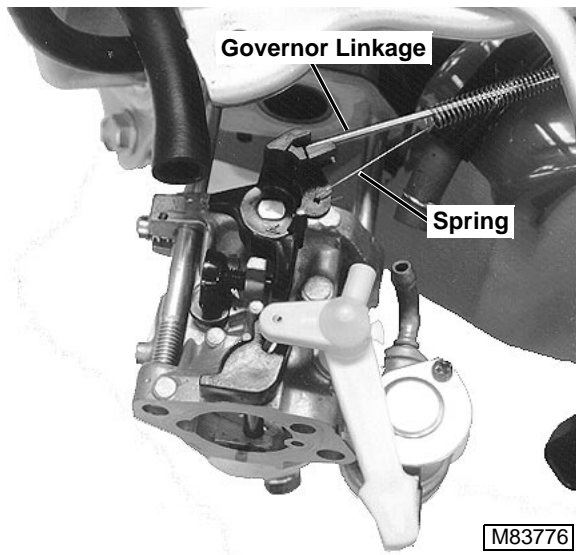

4. Slide carburetor forward (away from engine) until slot aligns with governor linkage. Disconnect linkage and spring.
5. Remove carburetor.

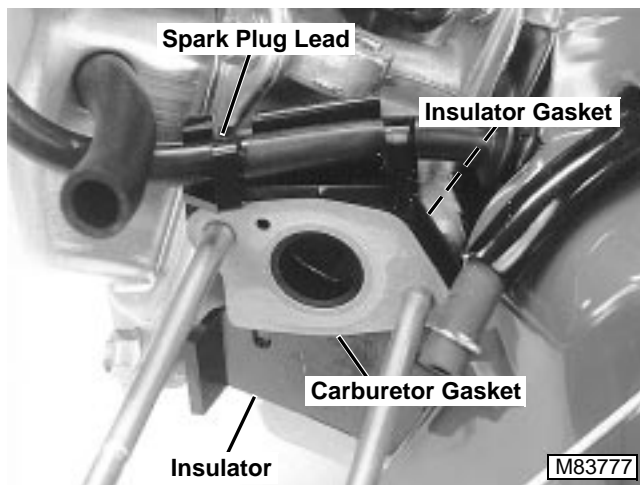

NOTE: Throttle plate assembly removed for photo clarity only.

6. Remove spark plug lead from insulator.
7. Remove insulator and gaskets.

Installation is done in the reverse order of removal.

- Use new gaskets for Installation.
- Tighten air cleaner housing flange nuts to **8.5 N•m (6 lb-ft)**.
- Adjust engine slow idle speed. (See SLOW IDLE SPEED ADJUSTMENT on page 3-22.)
- Adjust engine fast idle speed. (See GOVERNOR/FAST IDLE SPEED ADJUSTMENT on page 3-23.)

Disassembly/Assembly

ATTENTION!

DO NOT attempt to repair, replace jets, or adjust the engine emissions carburetor unless you are a factory trained technician with authorization to service CARB/EPA Certified Emissions Carburetors.



CAUTION

Gasoline is extremely flammable. DO NOT smoke. Always work in a ventilated area away from open flame or spark producing equipment, this includes equipment that utilizes pilot lights.

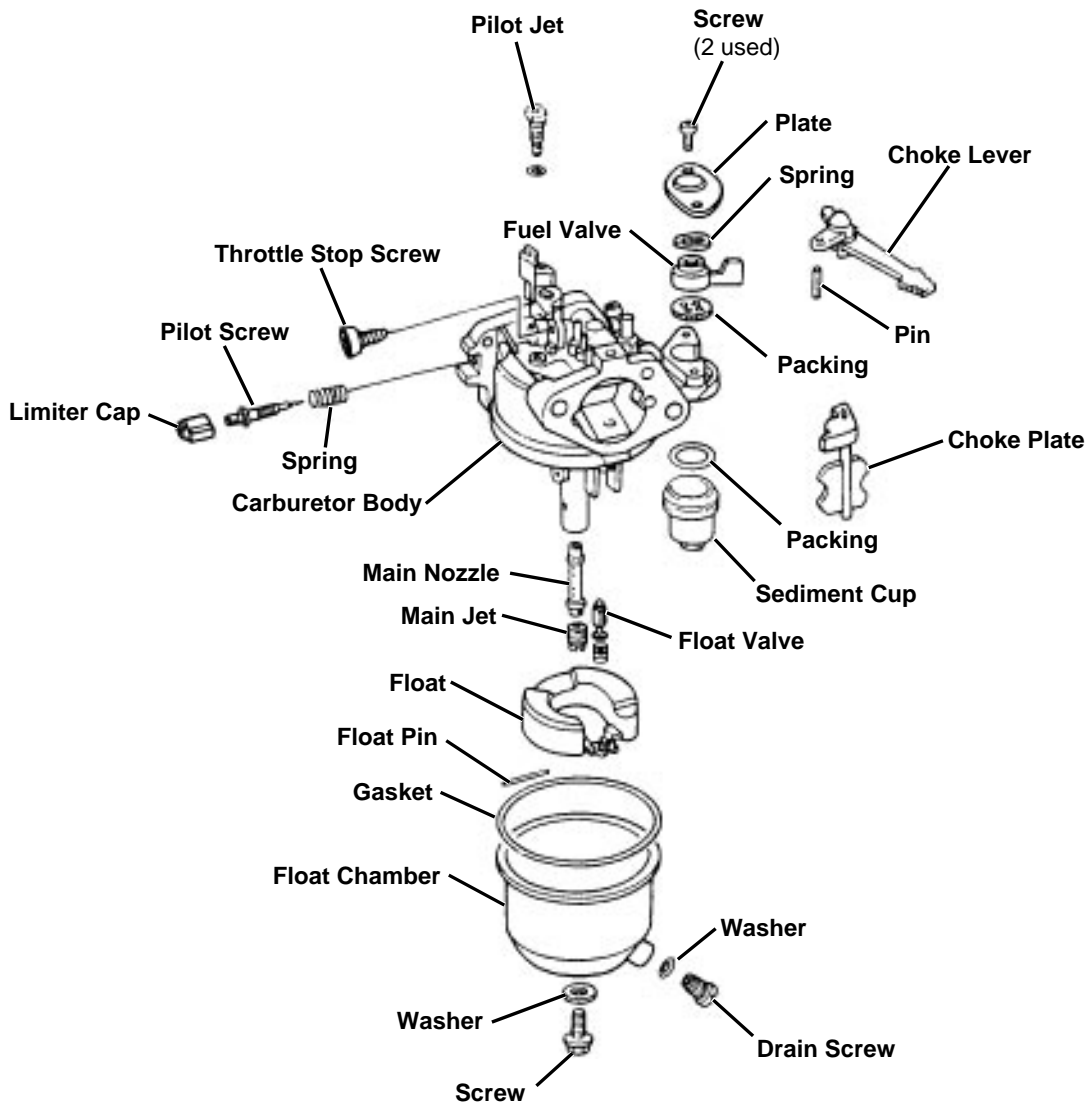

M83879

Clean/Inspect/Rebuild

IMPORTANT: DO NOT clean holes or passages with small drill bits or wire.

NOTE: If all rubber or plastic parts cannot be removed for cleaning, use a cleaning solvent with a high flash point that will not damage these parts when cleaning.

Leave pilot screw and limiter cap in place during cleaning. Removal of limiter cap requires breaking the pilot screw. Remove only if replacement of screw is required. If replacement is required, see Pilot Screw and Limiter Cap Replacement.

1. Remove rubber and plastic parts from carburetor. Soak all carburetor metal parts in a carburetor cleaning solution for 1/2 hour maximum.



CAUTION

Reduce compressed air to less than 210 kPa (2 bar) (30 psi) when using for cleaning purposes. Clear area of bystanders, guard against flying chips, and wear personal protection equipment including eye protection.

IMPORTANT: Rinse carburetor parts in warm water to neutralize corrosive action of cleaner on aluminum.

2. Rinse carburetor parts in warm water and dry with compressed air. DO NOT use rag or paper to dry parts; lint can plug holes and passages in carburetor.
3. Inspect all parts for wear or damage:
 - Inspect the carburetor body for wear or damage. Verify all sealing surfaces and flanges are smooth and free of nicks and burrs. Replace as necessary.

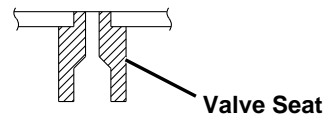

Float Valve

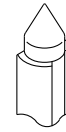

Good

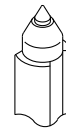

Worn (Replace)

M83880

- Inspect inlet needle for wear or damage. The tip should be smooth, without any grooves, scratches or tears. If worn or damaged, replace the float assembly and carburetor body as a set.
- Check float level height. (See Float Level Adjustment procedure on page 3-36.)

Pilot Screw and Limiter Cap Replacement

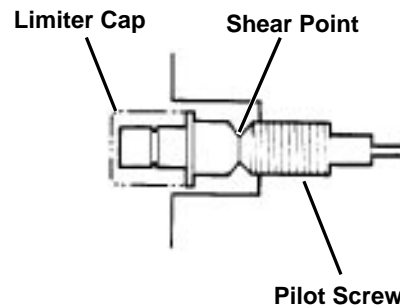

NOTE: Removal of limiter cap requires breaking the pilot screw. Remove only if replacement of screw is required.

1. Remove broken pilot screw.

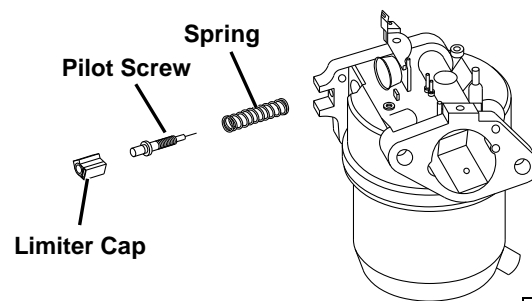

2. Place spring on pilot screw and install screw in carburetor.
3. Turn pilot screw in (clockwise) until lightly seated, then turn out (counterclockwise) **1-5/8 turns**.

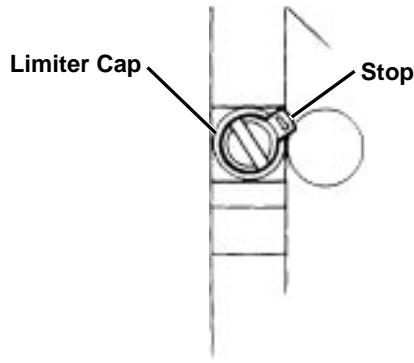

M83883

IMPORTANT: DO NOT allow the pilot screw to turn while installing limiter cap.

4. Apply Loctite 660 to inside of limiter cap.
5. Install limiter cap on pilot screw.

Float Level Adjustment

1. Assemble carburetor (minus the float chamber).
2. Place carburetor with engine-side mounting flange down on a flat, level surface.



M83910

3. Measure the distance between the top of the float and carburetor body with the float valve resting against the seat as shown. **DO NOT** compress the spring. The float height should measure **13.7 mm (0.54 in.)**.
4. Replace the float and/or float valve if the measurement is out of specification.

BLOWER HOUSING ASSEMBLY

Removal/Installation

1. Removal air cleaner assembly. (See AIR CLEANER ASSEMBLY—Removal/Installation on page 3-30.)

CAUTION

Gasoline vapor is explosive. **DO NOT** expose to spark or flame. Serious personal injury can result.

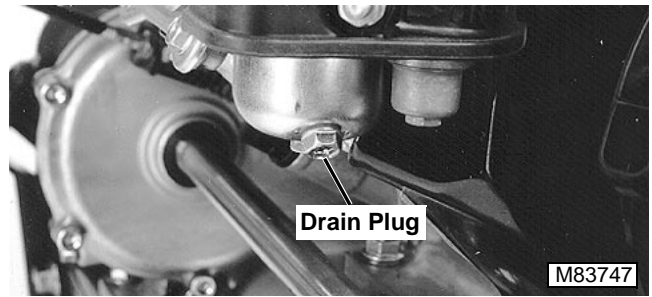

NOTE: Fuel tank capacity is approximately 3.6 L (0.95 qt).

2. Remove drain plug and drain fuel into a properly marked container.

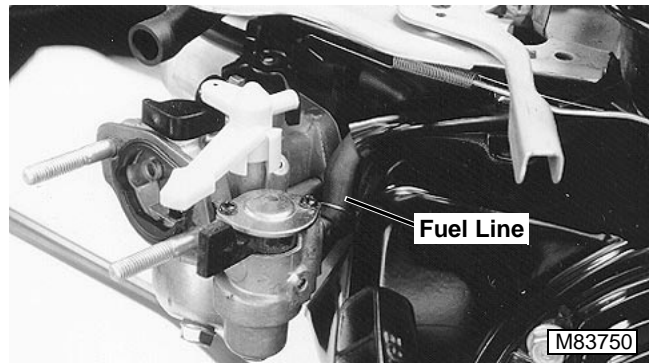

3. Disconnect fuel line at carburetor.

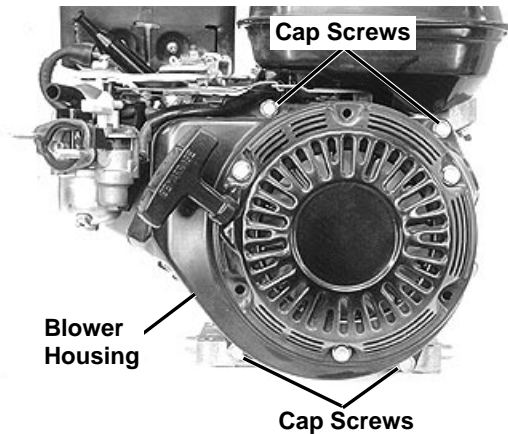

4. Remove four cap screws.
5. Remove blower housing.

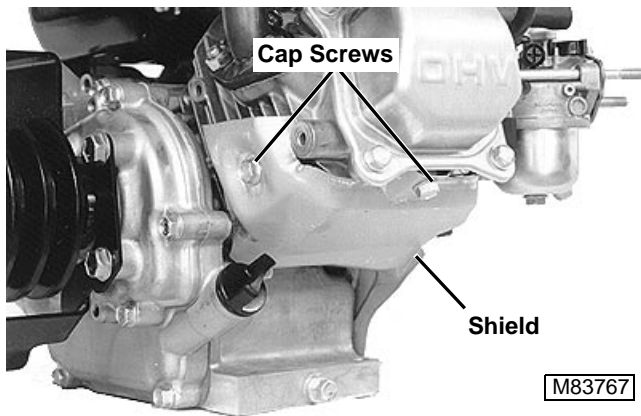

6. Remove two cap screws.
7. Remove shield.

Installation is done in the reverse order of removal.

RECOIL STARTER

Removal/Installation

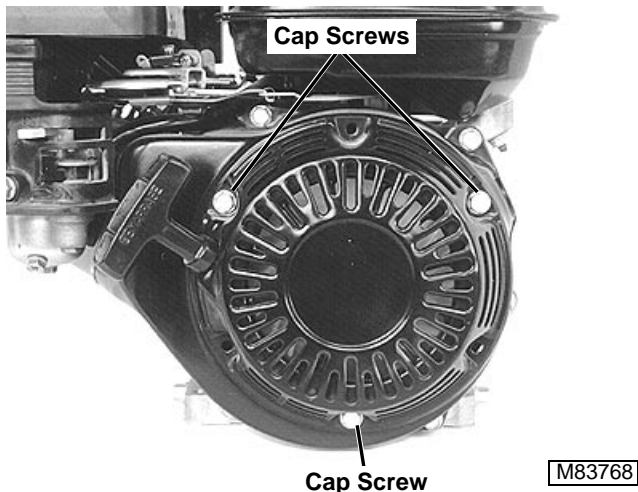

1. Remove three cap screws.
2. Remove recoil starter.

Installation is done in the reverse order of removal.

- Remove dirt and debris before installation.
- Position recoil starter for best starter grip location.

Disassembly/Inspection



CAUTION

Recoil spring is wound under tension. DO NOT let spring fly loose. Hold spring firmly in place while replacing. Wear safety glasses and gloves to protect yourself from possible injury.

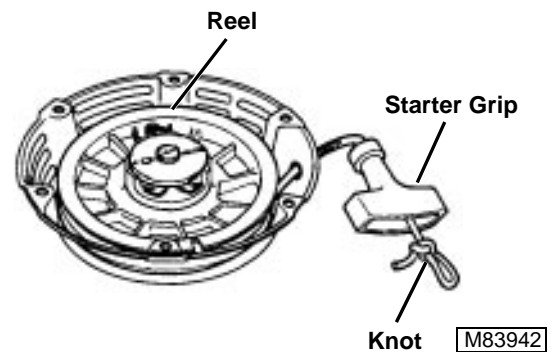

1. Hold reel and carefully feed starter rope out until there is enough slack to untie knot.
2. Remove starter grip.
3. Hold reel and slowly allow the spring to relieve tension.

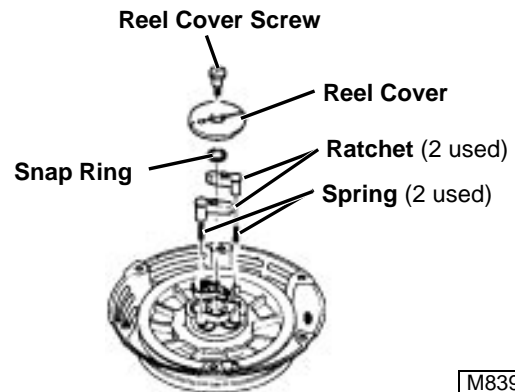

4. Loosen reel cover screw and remove reel cover.
5. Remove ratchets and springs.

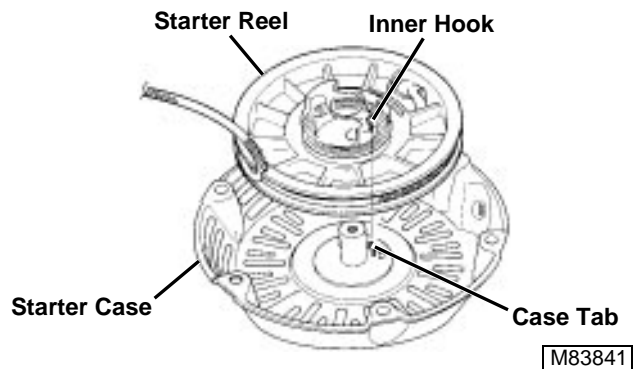

6. Remove the starter reel and spring from the starter case.
7. Inspect all parts for wear or damage. Replace parts as necessary.

Assembly



CAUTION

Recoil spring is wound under tension. DO NOT let spring fly loose. Hold spring firmly in place while replacing. Wear safety glasses and gloves to protect yourself from possible injury.

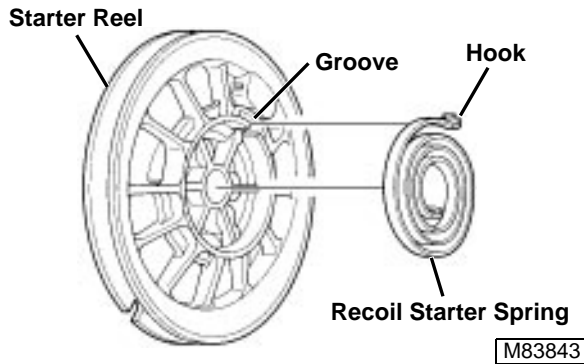

1. Insert hook on outer side of spring into groove on inside of reel.

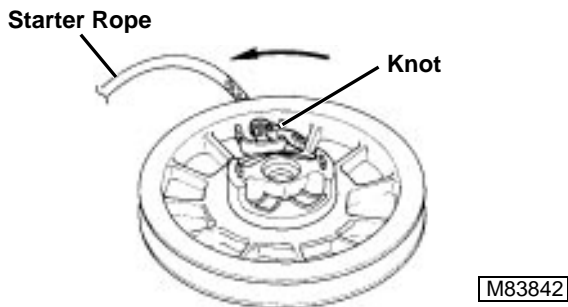

NOTE: Leave approximately 30 cm (12 in.) of rope outside starter reel.

2. Route starter rope through starter reel and tie as shown. Wind starter rope around reel in direction of arrow. Leave approximately 30 cm (12 in.) of rope outside starter reel.

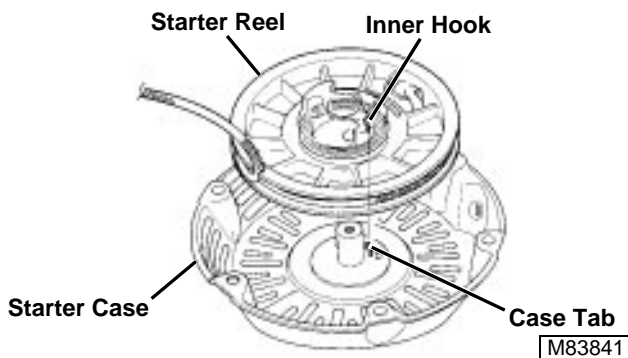

3. Install starter reel on starter case with spring inner hook anchored to case tab.



4. Hold starter case and rotate starter reel two revolutions in direction of arrow for preliminary winding.



5. Route starter rope through starter case rope guide and pull outward.
6. Route starter rope through starter grip and tie as shown.

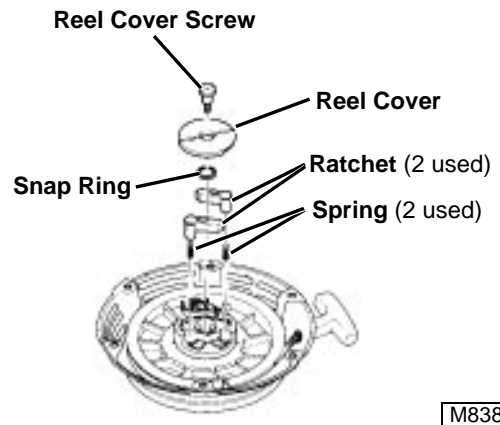

7. Install ratchets, springs and reel cover. Install and tighten reel cover bolt.
8. Check operation of the ratchet by pulling the starter rope several times.

IGNITION COIL

Removal/Installation

1. Remove fuel tank. (See FUEL TANK—Removal/Installation on page 3-27.)
2. Remove blower housing. (See BLOWER HOUSING—Removal/Installation on page 3-36.)
3. Remove throttle plate assembly. (See THROTTLE PLATE ASSEMBLY—Removal/Installation on page 3-32.)

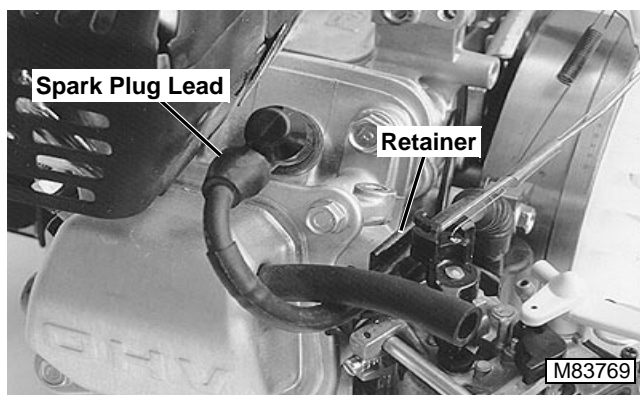

4. Disconnect spark plug lead from spark plug and remove lead from retainer.

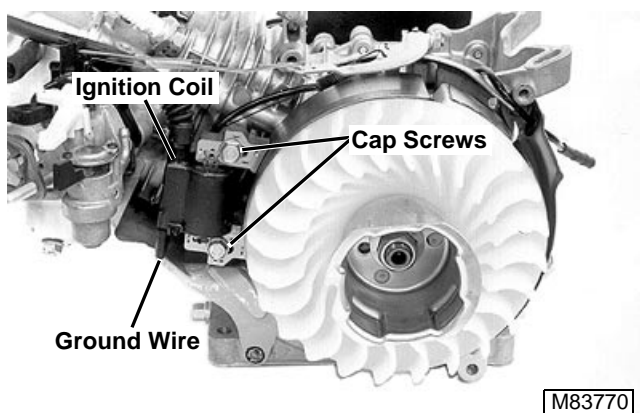

5. Disconnect ground wire.
6. Remove cap screws and ignition coil.

Installation is done in the reverse order of removal.

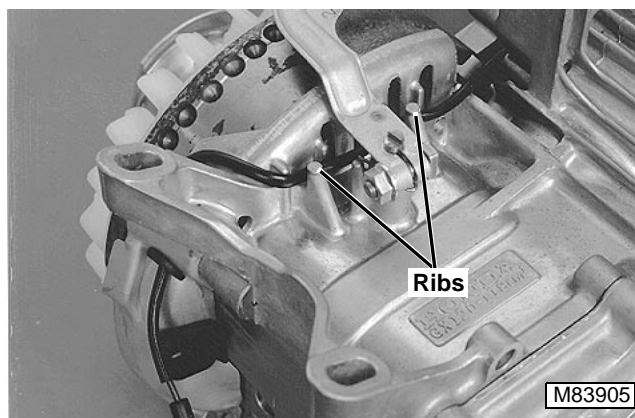

- Secure ignition wire into ribs on crankcase and through grommet.
- Adjust air gap. (See Air Gap Adjustment procedure.)

Air Gap Adjustment

1. Turn flywheel magnet away from ignition coil.
2. Loosen ignition coil mounting cap screws.

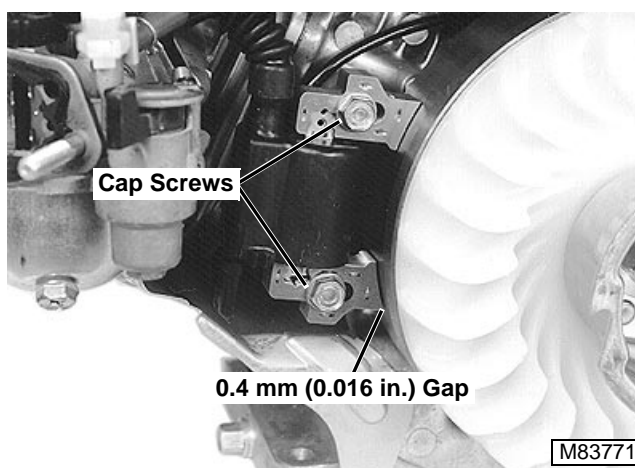

3. Insert an 0.4 mm (0.016 in.) feeler gauge between flywheel and ignition coil.
4. Push ignition coil against flywheel and tighten mounting cap screws.
5. Turn flywheel to remove feeler gauge.

Test

Primary Side:

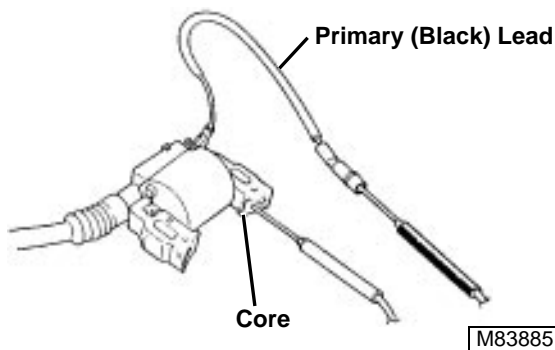

Measure resistance between ignition coil primary (black) lead and iron coil. Replace ignition coil if resistance is not within **0.8—1.0 ohms**.

Secondary Side:

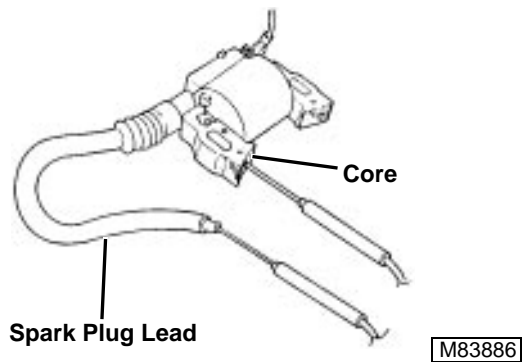

NOTE: A false reading will be obtained if the spark plug cap is not removed.

1. Remove spark plug cap.
2. Measure resistance between the end of the spark plug lead and iron coil. Replace ignition coil if resistance is not within **5.9—7.1 K ohms**.

FLYWHEEL

Removal/Installation

1. Remove ignition coil. (See IGNITION COIL—Removal/Installation on page 3-39.)

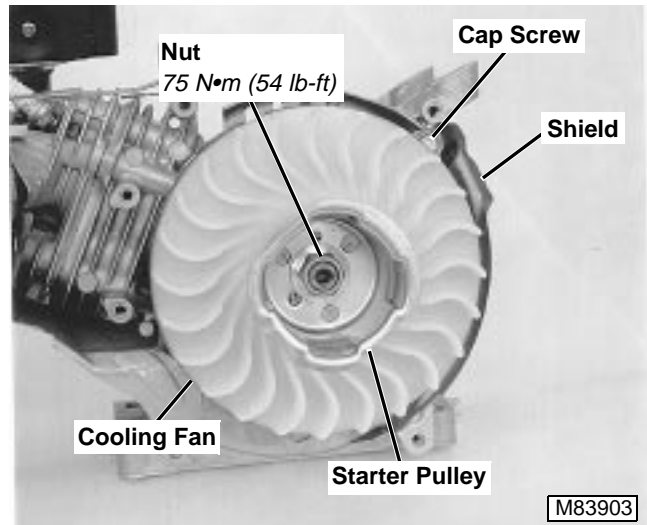

2. Remove cap screw and shield.
3. Remove flywheel nut.
4. Remove starter pulley and cooling fan.

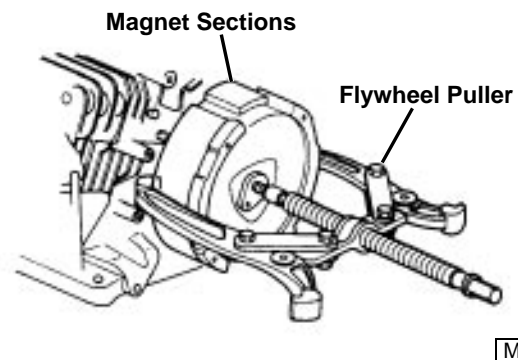

IMPORTANT: Use a puller to remove flywheel. Avoid attaching puller to the magnet sections. To avoid possible damage, **DO NOT** hit the flywheel with a hammer to loosen.

5. Using a puller, remove flywheel and key.

Installation is done in the reverse order of removal.

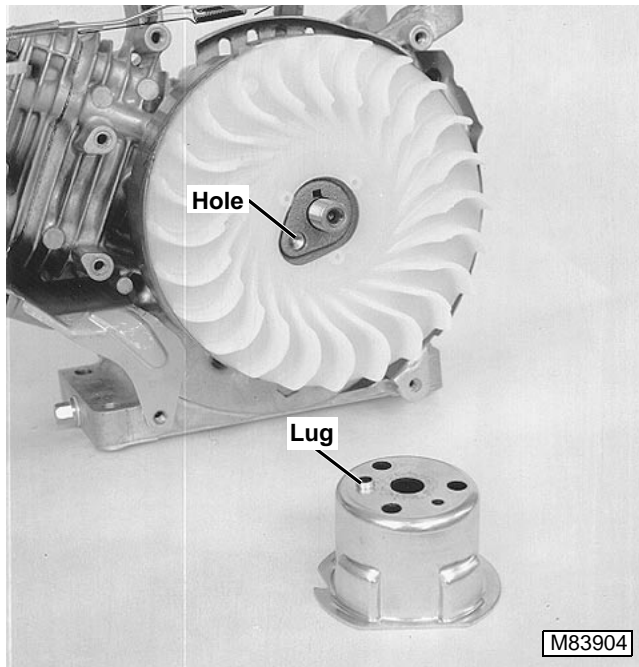

- Align lug on starter pulley with hole on flywheel.
- Tighten flywheel nut to **75 N•m (54 lb-ft)**.

ROCKER ARM COVER

Removal/Installation

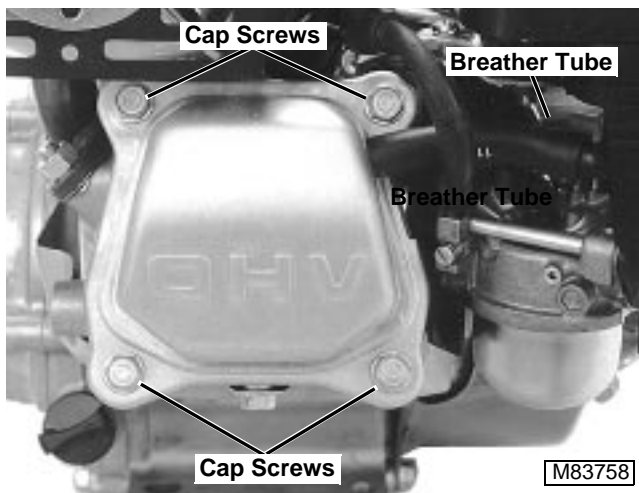

1. Remove four cap screws.
2. Disconnect breather tube at air cleaner assembly.
3. Remove rocker arm cover and gasket.

Installation is done in the reverse order of removal.

- Remove gasket material for mating surfaces of head and rocker arm cover before installation.
- Use new gasket for installation.

CYLINDER HEAD AND VALVES

Removal/Installation

1. Remove carburetor. (See CARBURETOR—Removal/Installation on page 3-32.)
2. Remove throttle plate assembly. (See THROTTLE PLATE ASSEMBLY—Removal/Installation on page 3-32.)
3. Remove muffler. (See MUFFLER—Removal/Installation on page 3-28.)
4. Remove blower housing. (See BLOWER HOUSING—Removal/Installation on page 3-36.)
5. Remove rocker arm cover. (See ROCKER ARM COVER—Removal/Installation on page 3-41.)
6. Disconnect spark plug lead.

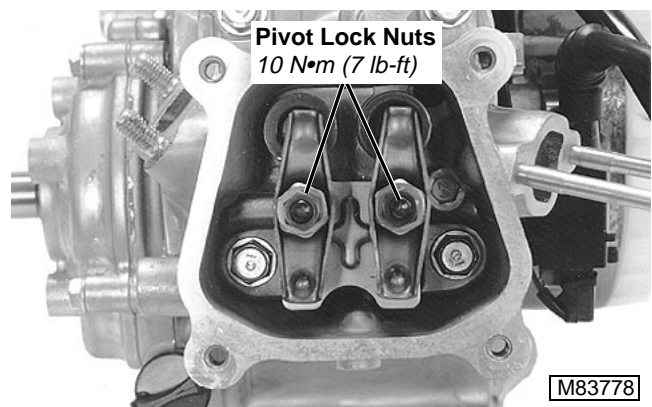

7. Remove rocker arm pivot locknuts and remove rocker arm pivots and rocker arms.
8. Remove push rods.

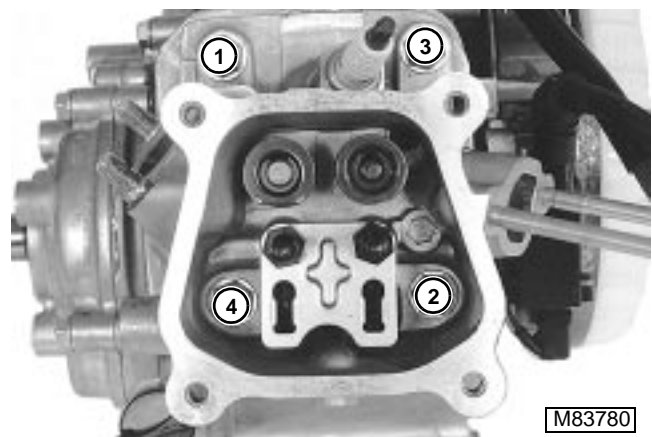

IMPORTANT: Loosen cylinder head bolts 1/4 turn at a time in the sequence shown to avoid warping the cylinder head.

9. Loosen head bolts in the sequence shown .
10. Remove head bolts, cylinder head and gasket.
11. Disassemble and inspect cylinder head and valves. (See Inspection procedures on page 3-43.)

Installation is done in the reverse order of removal.

- Use new gaskets for installation.

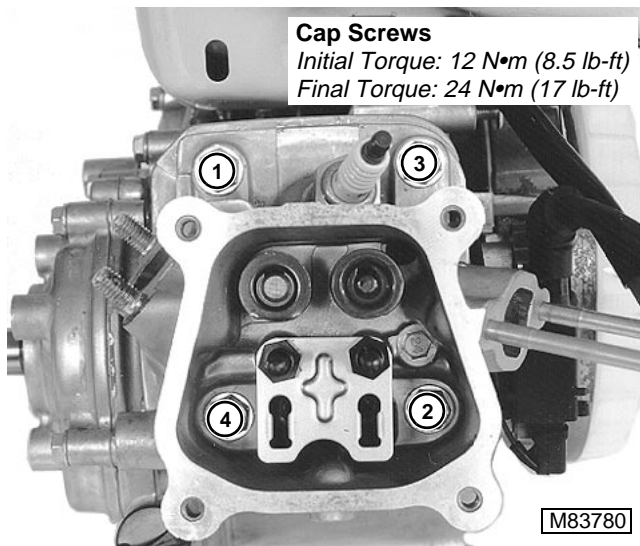

IMPORTANT: Torque should be applied in the sequence shown in increments.

- Tighten cap screws in sequence shown to initial torque of **12 N•m 8.5 lb-ft**. Finish tightening cylinder head to final torque of **24 N•m (17 lb-ft)**.
- Adjust valve clearance. (See VALVE CLEARANCE CHECK AND ADJUSTMENT on page 3-24.)

Disassembly/Assembly

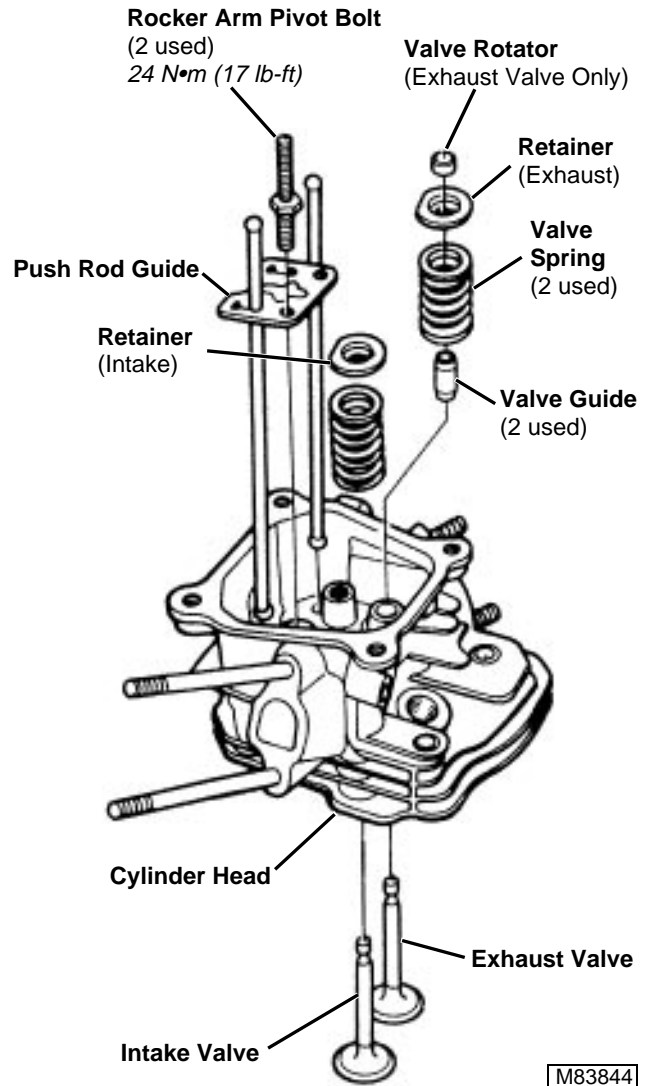

- Inspect all parts for wear or damage. (See Inspection procedures.)

IMPORTANT: If valve rotator is not installed, exhaust valve may drop into cylinder when engine is started.

- Apply a light coat of clean engine oil to intake and exhaust valve stems during assembly.
- Tighten rocker arm pivot bolts to **24 N•m (17 lb-ft)**

Inspection

Cylinder Head:

1. Remove carbon deposits from combustion chamber using SCOTCH-BRITE[®] abrasive pads or an equivalent.



CAUTION

Reduce compressed air to less than 210 kPa (2 bar) (30 psi) when using for cleaning purposes. Clear area of bystanders, guard against flying chips, and wear personal protection equipment including eye protection.

2. Clean head with a suitable solvent and dry with compressed air.
3. Inspect head for cracks or broken cooling fins.
4. Inspect gasket surface for burrs and nicks.

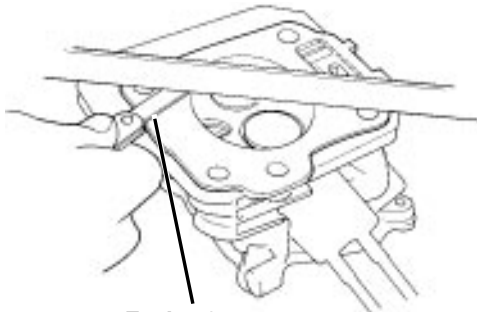

Feeler Gauge

M83845

5. Use a straight-edge and feeler gauge to check head for distortion at several points around head. Replace head if distortion is greater than **0.10 mm (0.004 in.)**.

Valve Guides:

1. Clean inside of valve guides with a valve guide cleaner.



M83846

2. Measure inside diameter of valve guides. Valve guides should measure **5.50 mm (0.217 in.)**. Replace valve guides if inside diameter is **greater than 5.572 mm (0.2194 in.)**. (See Valve Guide Replacement on page 3-44.)
3. Subtract the outside diameter of the valve stems from inside diameter of valve guides to determine guide-to-stem clearance.

Intake Guide-to-Stem Clearance

Standard **0.02—0.044 mm (0.0008—0.0017 in.)**

Wear Limit. **0.10 mm (0.004 in.)**

Exhaust Guide-to-Stem Clearance

Standard **0.06—0.087 mm (0.0024—0.0034 in.)**

Wear Limit. **0.12 mm (0.005 in.)**

4. If guide-to-stem clearance exceeds wear limit, determine if new guides would bring clearance within specifications. If so, replace guides. (See Valve Guide Replacement on page 3-44.) If guide-to-stem clearance would still exceed wear limit, replace both guides and valves.

Valve Seats:



M83847

1. Measure valve seat width. Recondition valve seat if measurement is less than **0.8 mm (0.03 in.)** or greater than **2.0 mm (0.08 in.)**.

Valve Springs:

1. Inspect springs for pitting, rust and burrs. Replace if necessary.

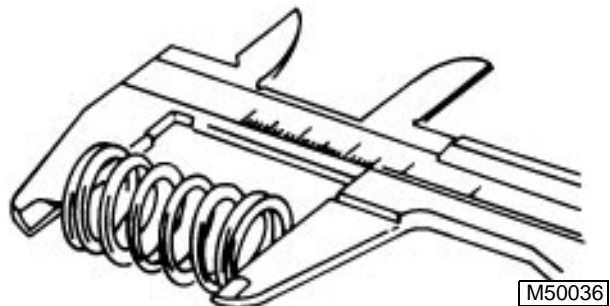

M50036

2. Measure spring free length. Replace spring if measurement is **less than 29.5 mm (1.16 in.)**.

Intake and Exhaust Valves:

1. Remove carbon from valve head, face and stem with a power-operated wire brush. Be sure carbon is removed, not merely burnished.
2. Inspect valve head, face and stem for defects. Replace if necessary.



M53961

3. Measure outside diameter of intake valve stem. Replace if diameter is less than **5.318 mm (0.2094 in.)**.
4. Measure outside diameter of exhaust valve stem. Replace if diameter is less than **5.275 mm (0.2077 in.)**.

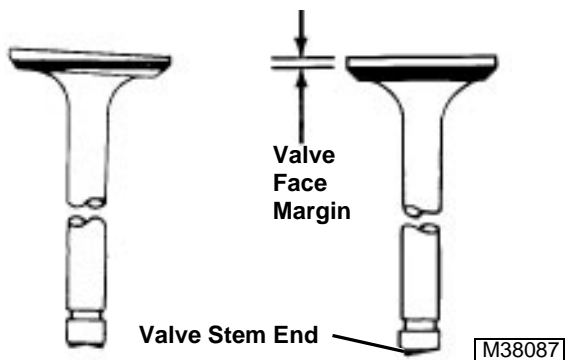

M38087

5. Replace warped valves or valves with less than **0.60 mm (0.024 in.)** margin. Valve stem ends should be ground square before checking valve-to-tappet clearance.

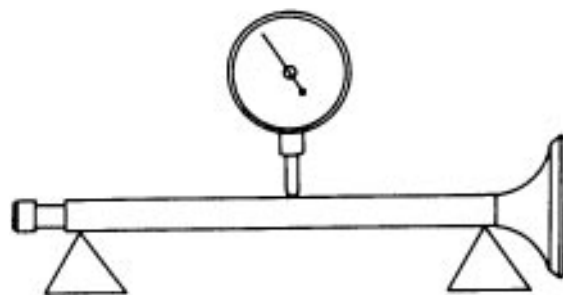

M51753

6. Check valve stem for bends using V-blocks and a dial indicator. Turn valve slowly and read variation on indicator. Replace valve if variation is **greater than 0.03 mm (0.001 in.)**.

Valve Guide Replacement

1. Disassemble and thoroughly clean the cylinder head. (See Disassembly/Assembly procedures on page 3-42.)
2. Chill the replacement valve guides in a freezer for about one hour prior to installation.



CAUTION

To prevent possible burns, use heavy gloves when handling hot cylinder head.

IMPORTANT: DO NOT heat cylinder head over **150°C (300°F)**. Excessive heat may loosen valve seats.

3. Using an oven, heat cylinder head to 150° C (300° F).
4. Remove cylinder head from oven and place on wood blocks with combustion chamber side up.

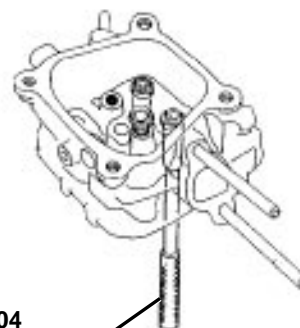

JDG504
5.5 mm Valve
Guide Driver

M83931

5. Using a JDG504 5.5 mm Valve Guide Driver, drive valve guides out from combustion chamber side.

6. Flip the cylinder head over (combustion chamber side down) and place on a flat, firm surface.
7. Remove valve guides from freezer as needed.

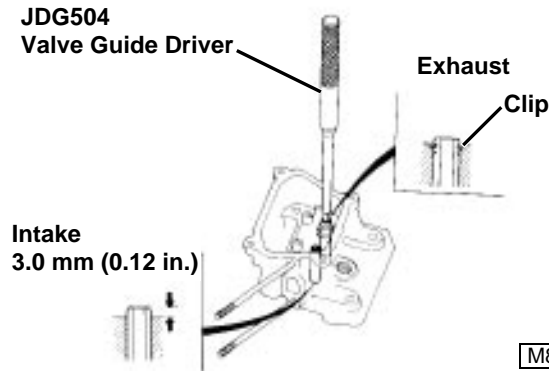

8. Install valve guides using a JDG504 Valve Guide Driver:
 - Exhaust guide is correctly installed when clip is fully seated against cylinder head casting.
 - Intake guide is correctly installed when the top of valve guide is **3.0 mm (0.12 in.)** from the cylinder head casting.

JDG1023
5.5 mm Valve Guide Reamer

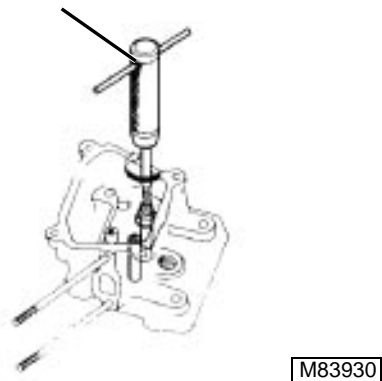

IMPORTANT: Allow the cylinder head to cool to room temperature before reaming valve guides.

9. Coat JDG1023 5.5 mm Valve Guide Reamer and valve guides with Stanisol or kerosene lubricant.
10. Rotate reamer clockwise through the valve guide. Continue rotating reamer while removing it from the valve guide.

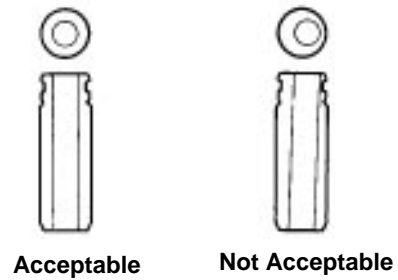

11. Thoroughly clean cylinder head to remove any cutting residue.
12. Inspect valve guide bore; it should be straight, round and centered in the valve guide.
13. Insert valve and check operation. Valve should move smoothly in guide. If valve does not move smoothly, the guide may have been damaged during installation. Replace valve guide if necessary.
14. Recheck valve-to-guide clearance. (See CYLINDER HEAD—Inspection on page 3-43.)

ANALYZE VALVES



Lead deposits on the intake valve are caused by exhaust gas leakage past the valve. This indicates that the valve is not seating properly.

IMPORTANT: DO NOT grind the exhaust valve or life will be shortened.

Lap the valves after resurfacing the seat to correct this condition.

NOTE: Be sure to reset valve-to-tappet clearance after grinding valve seats.

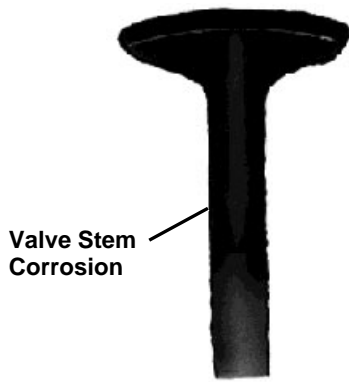

Valve Stem Corrosion

M5563

Valve stem corrosion is caused by moisture in the engine. Moisture in the fuel/air mixture can condense inside the engine when the engine is stopped and cools down.

Valve corrosion can also occur during storage. Fogging or pouring oil in the combustion chamber before storing helps prevent valve corrosion.

Corroded or pitted valves collect deposits and may cause sticking valves. Replace badly corroded or pitted valves.

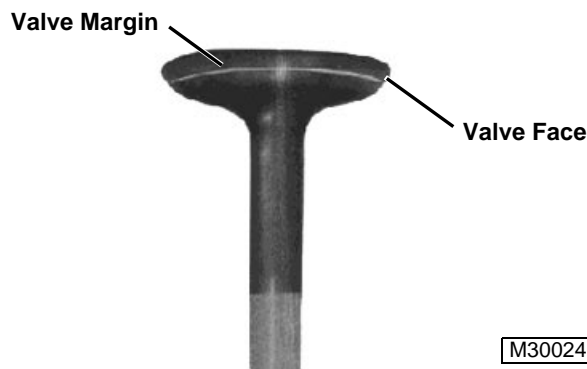

M30024

Exhaust valves are designed to function in temperature exceeding 2760°C (5000°F). However, when operating at high temperatures for long periods of time, valve burning may occur. Valves running too hot will show a dark discoloration of the valve stem into the area protected by the valve guide. Another indication is distortion of the valve margin and valve face. Valve seat inserts may also begin to burn away.

Other causes for valves running hot are worn valve guides or valve springs, incorrect valve clearance, lean fuel-air mixture, and incorrect or overheated spark plug.

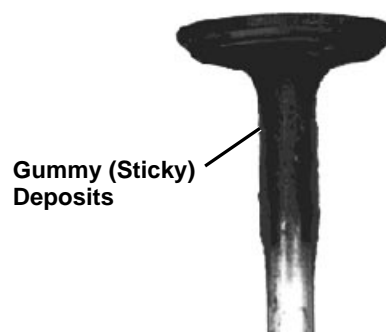

Gummy (Sticky) Deposits

M29936

Using old or stale gasoline is a common cause for sticky valves.

This gummy deposit can be seen on the valve. When this condition exists, the carburetor may also contain gummy deposits and will require cleaning.

Always use fresh gasoline and drain fuel tank, lines and carburetor before storing machine.

RECONDITION VALVE SEATS

1. Thoroughly clean the combustion chamber and valve seats to remove carbon deposits.
2. Inspect valve seats for damage. If seats are loose, warped or distorted beyond reconditioning, replace cylinder head. Pitted or worn seats can be refaced using a seat cutter.

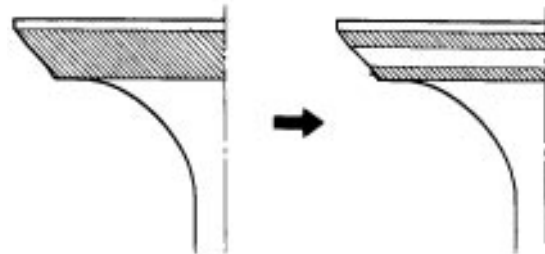

M83849

3. Apply a light coat of Prussian Blue or erasable felt-tipped marker ink to valve face.
4. Insert valve, and snap it closed against seat several times, DO NOT rotate valve. Transferred marking compound will show any area that is not concentric.

IMPORTANT: Turn cutter clockwise, DO NOT turn counterclockwise. Continue to turn cutter as you lift it off the valve seat.

5. To recondition seat, cut at a 45° angle to clean up seat.



Contact Too High



Contact Too Low

M83916

6. Use 30° or 60° cutters to narrow and adjust valve seats so that valve makes contact with the middle of the valve face.
 - Use 30° cutter to remove material from top edge of seat (contact too high).
 - Use 60° cutter to remove material from bottom edge of seat (contact too low).
7. Check valve seat width. If necessary, use a 45° cutter to adjust seat width.

LAP VALVES

If valve seat does not make proper contact, lap the valve into the seat:

1. Apply a small amount of fine lapping compound to face of valve.

Valve Lapping Tool



M83848

2. Grip head of valve with a vacuum cup tool and turn valve to lap valve to seat.
3. Lift valve from seat every 8 to 10 strokes. Lap until a uniform ring appears around the surface of the valve face.
4. Wash all parts in solvent to remove lapping compound. Dry parts.
5. Check position of lap mark on valve face. Lap mark must be on or near the center of valve face.

REDUCTION ASSEMBLY

Removal/Installation

NOTE: Crankcase capacity is approximately **0.6 L (0.63 qt)**.

1. Remove drain plug and drain crankcase.

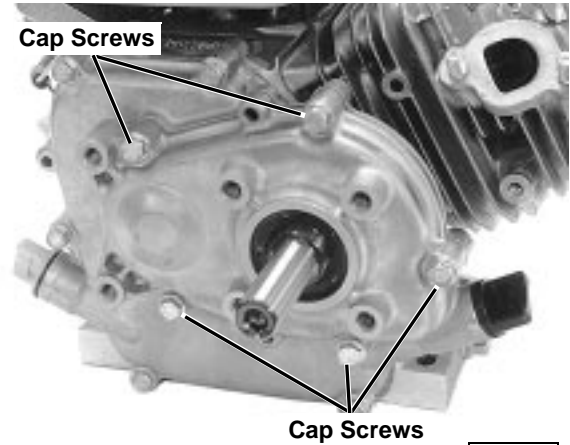

M83779

2. Remove caps screws, cover and gasket.

NOTE: Thrust washer may stick to cover.

3. Remove thrust washer from PTO shaft. Note orientation for assembly.



M83781

4. Hold flywheel with a strap wrench and remove cap screw and washer.
5. Remove drive sprocket, PTO shaft and chain as a unit.

NOTE: If chain is worn or damaged and must be replaced, replace drive sprocket, PTO shaft and chain as a set.

6. Inspect all parts for wear or damage. Replace as necessary.

7. Inspect ball bearing. Replace as necessary. (See Bearing/Oil Seal Replacement procedure.)
8. Replace seal. (See Bearing/Oil Seal Replacement procedure.)

Installation is done in the reverse order of removal.

- Remove gasket material from mating surfaces before installation.
- Use new gaskets for installation.
- Install thrust washer on PTO shaft with bevel facing ball bearing.

Bearing/Oil Seal Replacement

1. Remove reduction assembly cover. (See REDUCTION ASSEMBLY—Removal/Installation on page 3-47.)

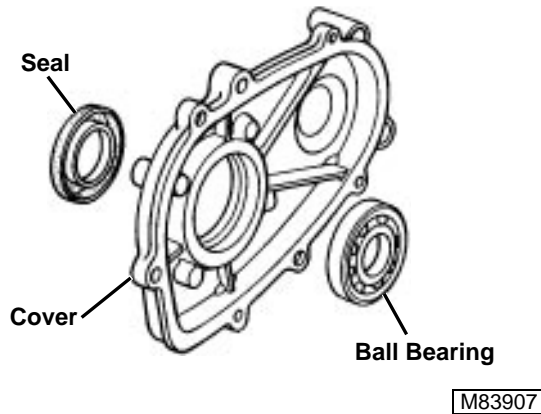

Bearing:

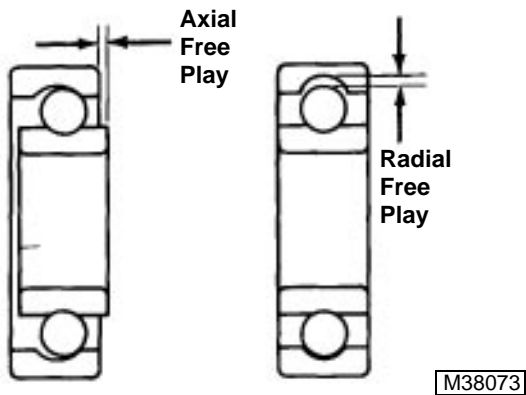

1. Spin bearing by hand and check for axial and/or radial free play. Replace bearing if it has excessive play or is noisy.

NOTE: Remove bearing only if replacement is required.

2. Remove oil seal.

3. Remove bearing using a driver set.
4. Apply a light coat of clean engine oil to bearing outer race.
5. Install bearing using a driver set until fully seated against housing.
6. Install new oil seal.

Oil Seal:

7. Remove worn or damaged seal using a screwdriver.
8. Pack lithium-based grease inside lips of seal.
9. Install seal with lip toward inside of cover using a seal driver set.

CRANKCASE COVER

Removal/Installation

NOTE: Crankcase capacity is approximately 0.6 L (0.63 qt).

1. Remove drain plug and drain crankcase.
2. Remove reduction assembly. (See REDUCTION ASSEMBLY—Removal/Installation on page 3-47.)

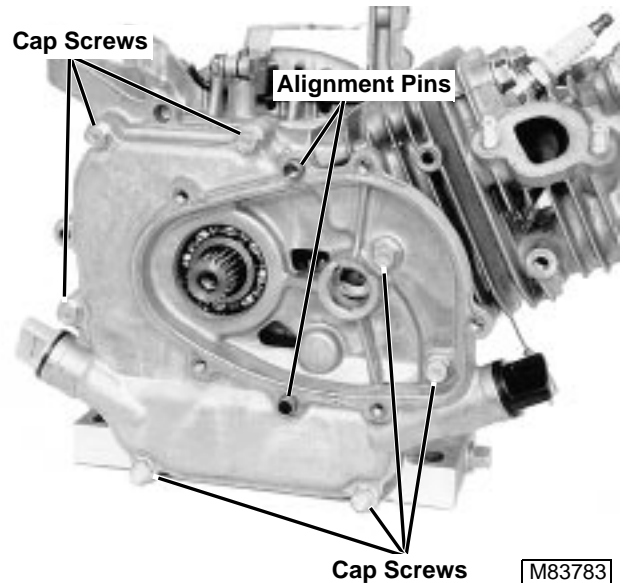

3. Remove alignment pins.
4. Remove seven cap screws.

Installation is done in the reverse order of removal.

- Remove gasket material from mating surfaces before installation.
- Use new gaskets for installation.
- Tighten cap screws to **12 N•m (9 lb-ft)**.

Bearing Inspection/Replacement

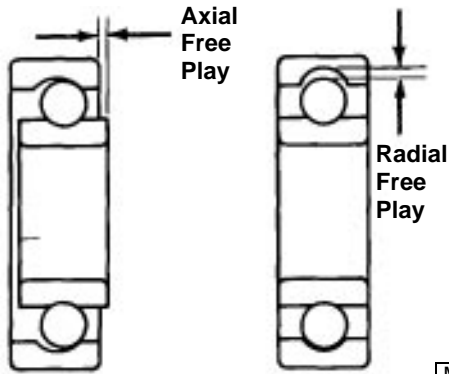

M38073

1. Spin bearing by hand and check for axial and/or radial free play. Replace bearing if it has excessive play or is noisy.

NOTE: Remove bearing only if replacement is required.

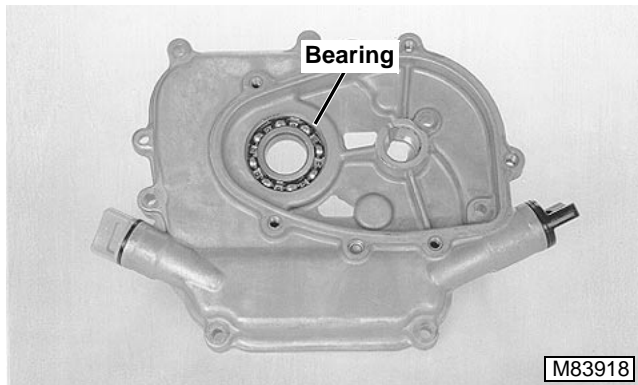

2. Drive bearing out from reduction cover side using a driver set.
3. Apply a light coat of clean engine oil to bearing outer race.
4. Install bearing using driver set until fully seated against housing.

CAMSHAFT AND TAPPETS

Removal/Installation

1. Remove cylinder head. (See CYLINDER HEAD—Removal/Installation on page 3-41.)
2. Remove crankcase cover. (See CRANKCASE COVER—Removal/Installation on page 3-48.)

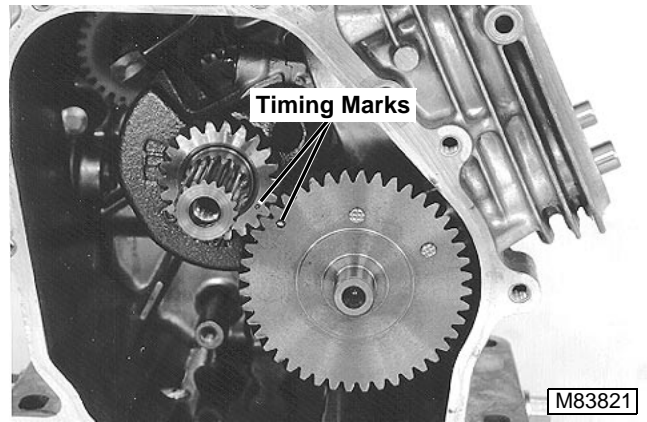

3. Rotate camshaft until timing marks align.
4. Remove and inspect camshaft. (See Inspection procedures.)

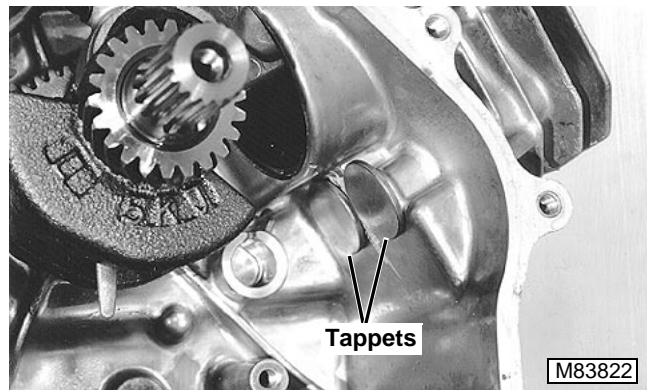

IMPORTANT: Tappets must be install in the same bores from which they were removed.

5. Mark each tappet to aid in installation.
6. Remove and inspect tappets for wear or damage. Replace if necessary.

Installation is done in the reverse order of removal.

- Apply a light coat of clean engine oil to tappets and bores and install tappets in original bores.
- Apply a light coat of clean engine oil to camshaft lobes and journals.
- Align timing marks when installing camshaft.

Inspection

1. Inspect camshaft for wear or damage. Replace if necessary.



M83887

2. Measure cam intake lobe height. Replace camshaft if lobe height is less than **27.45 mm (1.081 in.)**.
3. Measure cam exhaust lobe height. Replace camshaft if lobe height is less than **27.75 mm (1.083 in.)**.



M83888

4. Measure flywheel side journal and PTO side journal diameter. Replace camshaft if either journal diameter is less than **13.916 mm (0.5479 in.)**.



M83889

5. Measure inside diameter of camshaft holder in crankcase cover. Replace crankcase cover if diameter is greater than **14.048 mm (0.5531 in.)**.

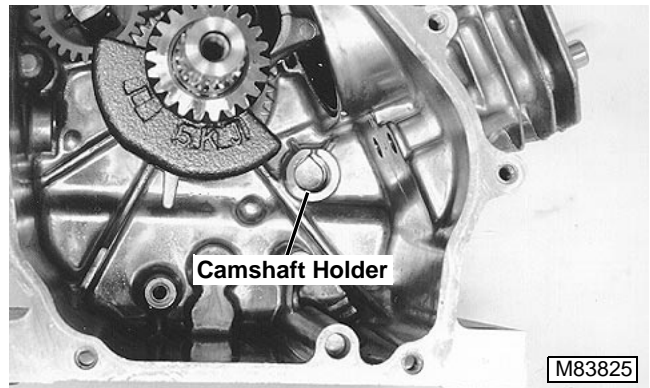

6. Measure inside diameter of camshaft holder in block. Replace block if diameter is greater than **14.048 mm (0.5531 in.)**.

PISTON AND CONNECTING ROD

Removal

1. Remove camshaft and tappets. (See CAMSHAFT AND TAPPETS—Removal/Installation on page 3-49.)
2. Check cylinder bore for carbon and varnish ridges. These ridges can cause piston damage if not removed.
3. If necessary, remove ridge from top of cylinder bore using a ridge reamer.

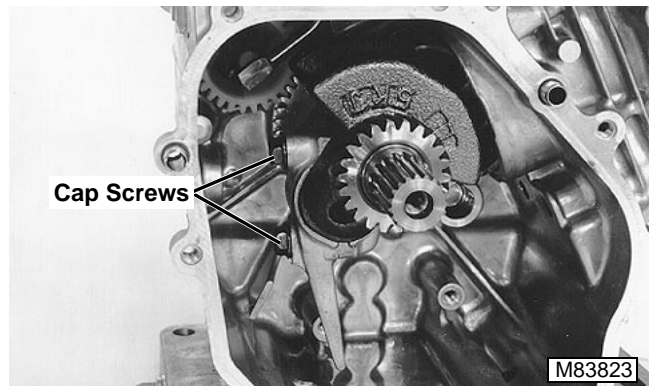

4. Turn crankshaft to expose connecting rod end cap.
5. Remove cap screws and connecting rod cap.
6. Push piston and connecting rod assembly from cylinder bore.
7. Disassemble and inspect all parts for wear or damage. (See Disassembly and Inspection procedures on page 3-51.)

Installation

1. Deglaze cylinder bore. (See CYLINDER BLOCK—Deglaze Cylinder Bore on page 3-60.)
2. Stagger piston ring end gaps 180° apart, but do not align with oil ring side rail end gaps.
3. Apply a light coat of clean engine oil to piston and rings. Compress rings with a ring compressor.
4. Apply a light coat of clean engine oil to cylinder bore, connecting rod bearing surface and ring compressor.

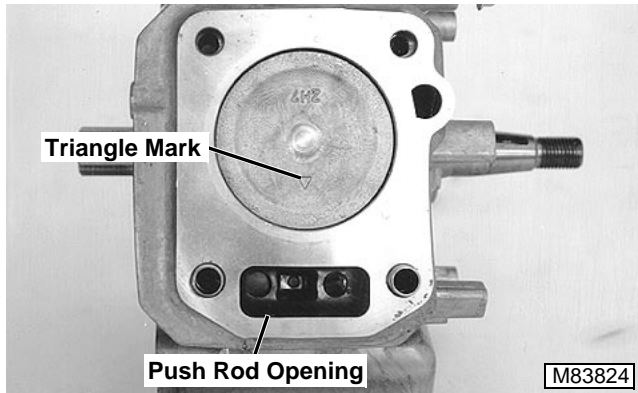

5. Install piston and connecting rod assembly in cylinder bore with triangle mark on piston facing the push rod opening.

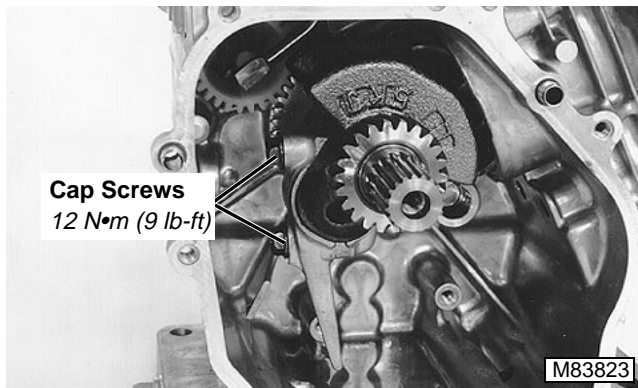

6. Install connecting rod cap with dipper toward camshaft and ribs on cap and connecting rod aligned. Tighten cap screws to **12 N•m (9 lb-ft)**.
7. Install camshaft and tappets, crankcase cover and cylinder head.

Disassembly

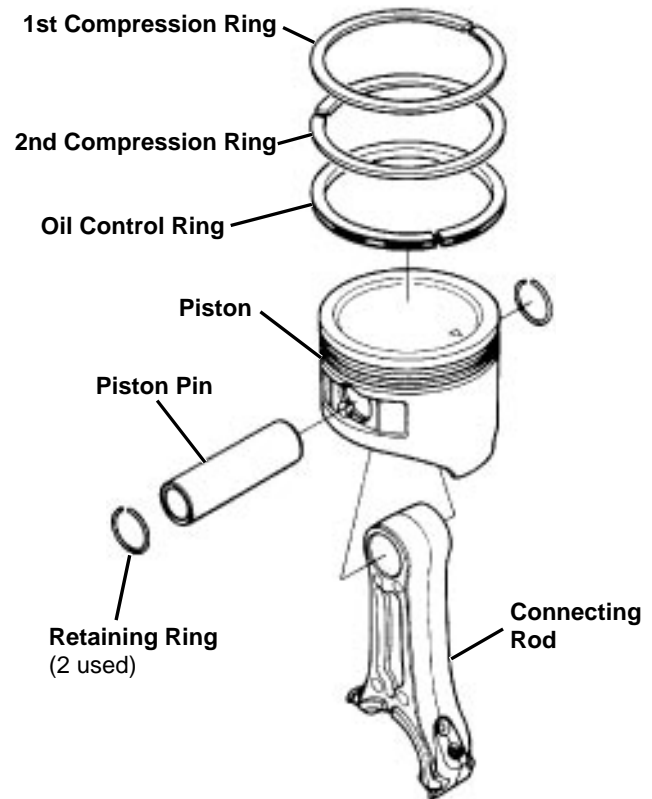

- Analyze piston and piston ring wear. (See ANALYZE PISTON RING WEAR on page 3-55 and ANALYZE PISTON WEAR on page 3-57.)
- Remove piston rings using a piston ring expander.

IMPORTANT: DO NOT reuse piston pin retaining rings. Always use new retaining rings for assembly.

- Inspect all parts for wear or damage. (See Inspection procedures.)

Assembly

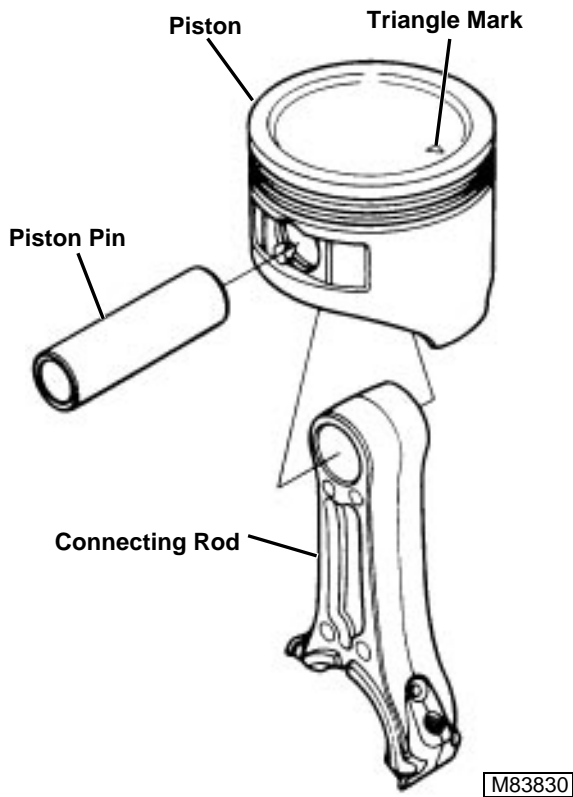

IMPORTANT: DO NOT reuse piston pin retaining rings.

1. Install connecting rod to piston with long end of connecting rod toward triangle mark on piston.
2. Apply a light coat of clean engine oil to piston pin and connecting rod bearing.
3. Install piston pin.

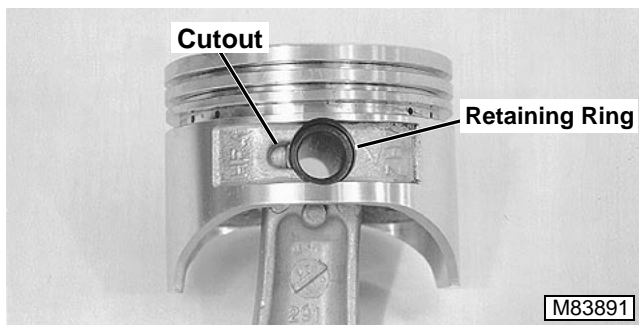

IMPORTANT: DO NOT align retaining ring gap with cutout in piston pin bore.

4. Install retaining rings by inserting one end in groove, and holding other end with a needle-nosed pliers, rotate the ring into place.

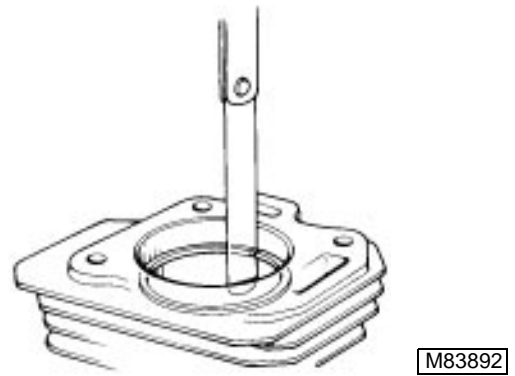

5. Before installing rings on piston, check ring end gap in cylinder bore. (See Check Piston Ring End Gap on page 3-55.)

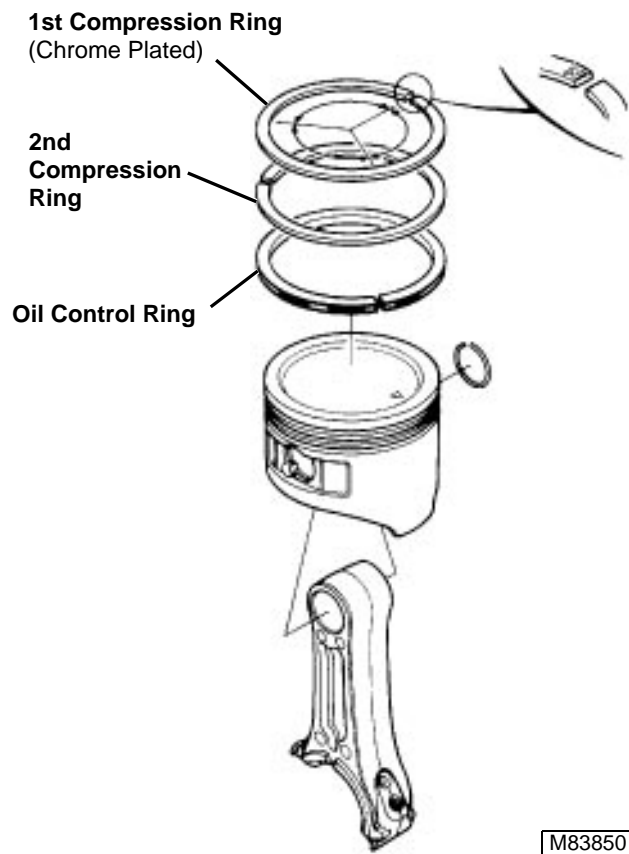

IMPORTANT: Install all rings with marking facing up.

Be sure that top and second compression rings are not interchanged.

DO NOT align any piston ring end gaps with piston pin bore.

NOTE: Rings should rotate freely in grooves after installation.

6. Install oil control and compression rings:
 - Install oil control ring in bottom groove with mark facing up. Position end gap approximately 45° away from triangle mark.
 - Install 2nd compression ring in middle groove with mark facing up. Position end gap approximately 120° away from end gap of oil control ring.
 - Install 1st compression ring in top groove with mark facing up. Position end gap approximately 120° away from end gap of 2nd compression ring.

Inspection

Piston:

IMPORTANT: DO NOT use a caustic cleaning solution or a wire brush to clean piston.

1. Remove all deposits from piston.

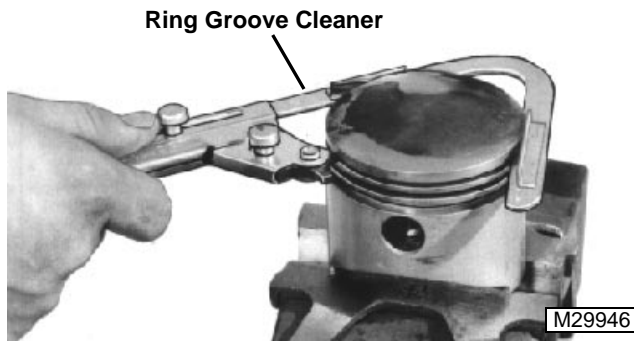

2. Clean carbon deposits from piston ring grooves with a ring groove cleaner. If cleaning tool is not available, break an old ring and use it to carefully clean groove.
3. Check that all oil return passages in grooves are open.
4. Inspect piston for scoring or fractures. Replace piston if damaged.

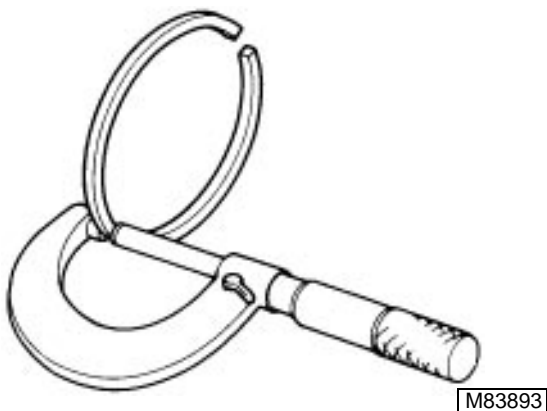

5. Measure 1st and 2nd compression ring thickness. Replace rings if measurement is less than **1.37 mm (0.054 in.)**.

6. Measure oil control ring thickness. Replace ring if measurement is less than **2.37 mm (0.093 in.)**.

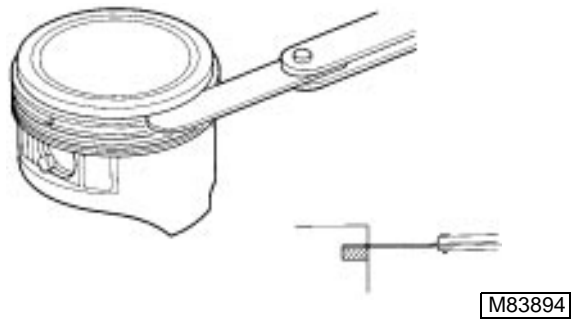

7. Using new rings, check piston ring-to-groove clearance at several points around piston. Replace piston if any clearance is greater than **0.15 mm (0.006 in.)**.

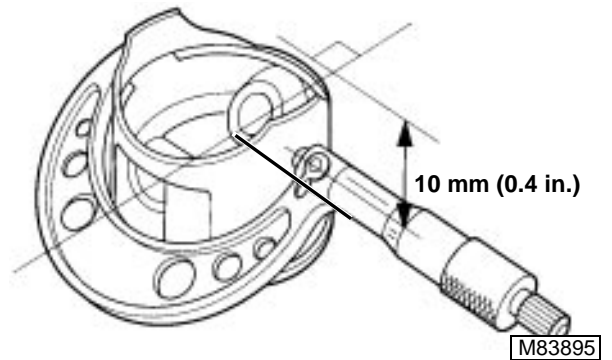

8. Measure piston outside diameter at a point 10 mm (0.4 in.) from the bottom of the skirt and 90° to the piston pin bore. Replace piston if outside diameter measures less than specifications.

NOTE: If the engine has had a previous major overhaul, an oversized piston may have been installed. Pistons and rings are available in 0.25 mm (0.010 in.) and 0.50 mm (0.020 in.) oversize.

Piston O.D. Specifications (Wear Limit):

Standard Piston	59.845 mm (2.3561 in.)
0.25 mm (0.010 in.)	
Oversize Piston	60.095 mm (2.3661 in.)
0.50 mm (0.020 in.)	
Oversize Piston	60.345 mm (2.3761 in.)

9. Measure cylinder bore diameter. (See CYLINDER BLOCK—Inspection on page 3-59.)
10. Subtract piston outside diameter measurement from cylinder bore measurement to determine piston-to-cylinder bore clearance.
11. Replace piston and/or rebore cylinder block if clearance is greater than **0.12 mm (0.005 in.)**. (See CYLINDER BLOCK—Rebore Cylinder Bore on page 3-60.)



M80427

12. Measure piston pin bore diameter in piston. Replace piston if measurement is greater than **13.048 mm (0.5137 in.)**.



M83896

3. Measure connecting rod piston pin bore. Replace connecting rod if measurement is greater than **13.07 mm (0.515 in.)**.

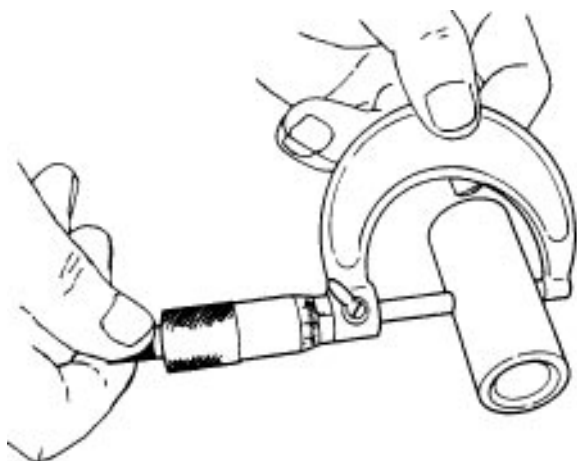

M83897

NOTE: If the engine has had a previous major overhaul, an undersized connecting rod may have been installed. A 0.25 mm (0.010 in.) undersize connecting rod is available.

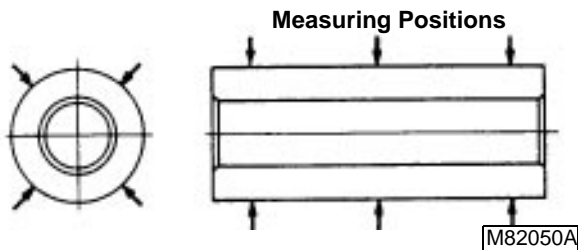

M82050A

13. Measure piston pin diameter at six places. Replace pin if any measurement is less than **12.954 mm (0.5100 in.)**.
14. Subtract piston pin outside diameter measurement from piston pin bore measurement to determine piston pin-to-bore clearance. Replace piston pin and/or piston if clearance is greater than **0.08 mm (0.003 in.)**.

4. Install connecting rod cap. Tighten cap screws to **12 N•m (9 lb-ft)**.
5. Measure connecting rod crankshaft bearing. Replace connecting rod if measurement is greater than specifications.

Crankshaft Bearing Diameter Specifications (Wear Limit):

Standard Crankshaft 26.066 mm (1.0262 in.)
0.25 mm (0.010 mm)
Undersize Crankshaft 25.816 mm (1.0164 in.)

Connecting Rod:

1. Analyze crankshaft and connecting rod wear. (See ANALYZE CRANKSHAFT AND CONNECTING ROD WEAR on page 3-59.)
2. Clean and inspect connecting rod. Replace if scored or damaged.

Check Connecting Rod Side Play

1. Remove crankshaft from cylinder block. (See CRANKSHAFT—Removal/Installation on page 3-58.)

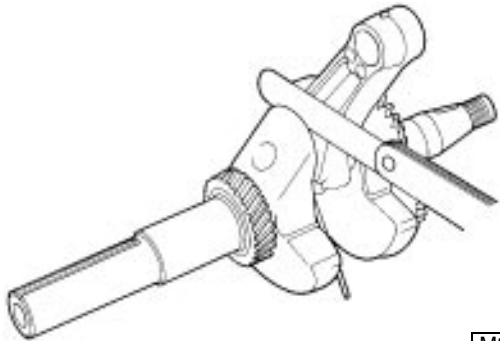

M83898

2. Install connecting rod on crankshaft. Tighten connecting rod cap screws to **12 N•m (9 lb-ft)**.
3. Measure connecting rod side clearance. Replace connecting rod and/or crankshaft if clearance is greater than **1.1 mm (0.043 in.)**.

Check Connecting Rod-to-Crankshaft Clearance

1. Remove crankshaft from cylinder block. (See CRANKSHAFT—Removal/Installation on page 3-58.)
2. Clean all oil from crankshaft journal and connecting rod bearing surfaces.

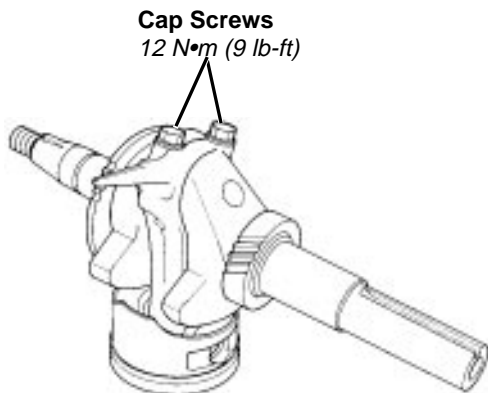

M83899

NOTE: DO NOT rotate crankshaft while Plastigauge is in place.

3. Place a piece of Plastigauge® on the crankshaft journal, and install connecting rod and cap. Tighten connecting rod cap screws to **12 N•m (9 lb-ft)**.

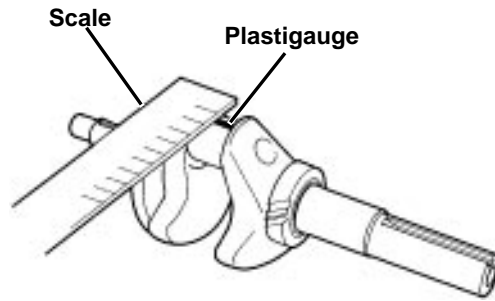

M83900

NOTE: If the engine has had a previous major overhaul, an undersized connecting rod may have been installed. A 0.25 mm (0.010 in.) undersize connecting rod is available.

4. Remove cap and measure Plastigauge®. If clearance is greater than **0.12 mm (0.005 in.)**, replace connecting rod and recheck clearance.
5. If after replacing connecting rod clearance is still beyond specifications, replace crankshaft.

Check Piston Ring End Gap

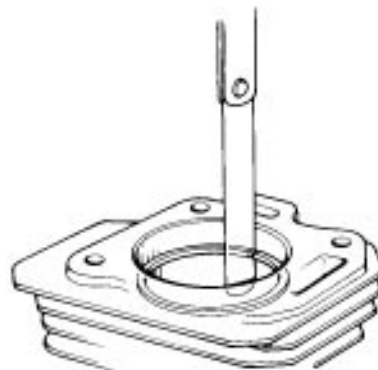

M83892

1. Install each ring squarely in bore approximately 25.4 (1.00 in.) down from top of cylinder.
2. Measure end gap. Replace rings if end gap is greater than **1.0 mm (0.04 in.)**.

ANALYZE PISTON RING WEAR

Rings of the wrong size or rings having improper end gaps will not conform to the shape of the cylinder. This results in high oil consumption and excessive blow-by.

Ring end gaps should be staggered on the piston during installation. (See PISTON AND CONNECTING ROD on page 3-50.) End gaps in alignment can also cause oil consumption and blow-by.

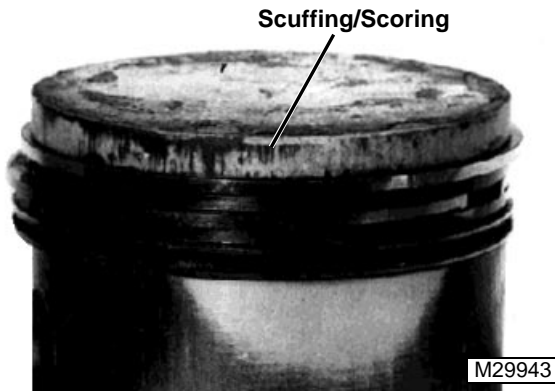

Light scuffing or scoring of both rings and piston occurs when unusually high friction and combustion temperatures approach the melting point of the piston.

When this condition exists, it is due to one or more of the following probable causes:

- Dirty cooling shroud and cylinder head.
- Lack of cylinder lubrication.
- Improper combustion.
- Wrong bearing or piston clearance.
- Too much oil in crankcase causing fluid friction.

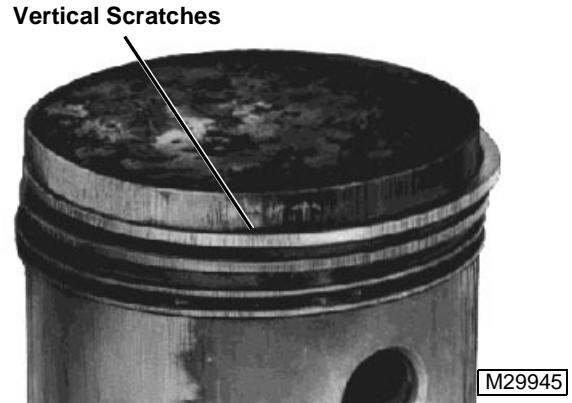

Vertical scratches across the piston rings are due to an abrasive in the engine. Abrasives may be airborne, may have been left in the engine during overhaul, or may be loose lead or carbon deposits.

When this condition exists, check for one or more of the following:

- Damaged, collapsed or improperly installed air filter.
- Loose connection or damaged basket between air cleaner and carburetor.
- Air leak around carburetor-to-cylinder head gasket.
- Air leak around throttle shaft.
- Failure to properly clean cylinder bore after reconditioning engine.

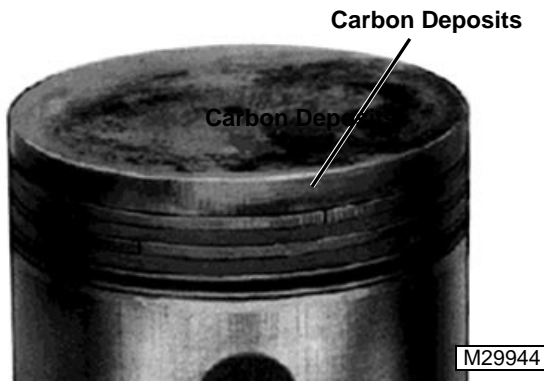

The engine operating at abnormally high temperature may cause varnish, lacquer or carbon deposits to form in the piston ring grooves making the piston rings stick. When this happens, excessive oil consumption and blow-by will occur.

Engine overheating and ring sticking is usually caused by one or more of the following:

- Overloading.
- Incorrect ignition timing.
- Lean fuel mixture.
- Dirty cooling fins.
- Incorrect oil.
- Low oil supply.
- Stale fuel.

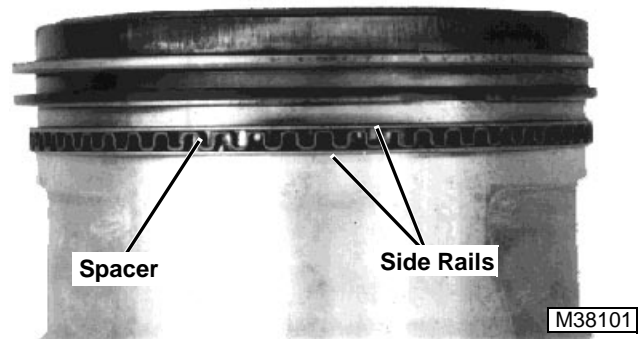

Abrasive particles in engine oil cause scratches on side rails of oil control ring. Inner spacer wear or distortion may cause:

- High oil consumption.
- Increased deposits in combustion chamber.
- Sticking compression rings.

Increased oil consumption may be caused by:

- Worn side rails with low tension.
- Worn or distorted inner spacer.

ANALYZE PISTON WEAR

Detonation is abnormal combustion causing excessive temperature and pressure in the combustion chamber. Commonly called knock, spark knock or timing knock, detonation occurs as the compressed fuel-air mixture ignites spontaneously to interrupt the normal ignition.



The following is a list of possible causes for detonation.

- Pre-ignition.
- Lean fuel mixture.
- Low octane fuel.
- Advanced ignition timing.
- Engine lugging.
- Build-up of carbon deposits on piston or cylinder head, causing excessive compression.
- Wrong cylinder head or milling of head increasing compression ratio.



Pre-ignition is the igniting of the fuel-air mixture prior to regular ignition spark. Pre-ignition causes shock, resulting in pings, vibration, detonation and power loss. Severe damage to piston, rings and valves results from pre-ignition.

Check the following for causes of pre-ignition:

- Internal carbon deposits.
- Incorrect spark plug (high heat range).
- Broken ceramic in spark plug.
- Sharp edges on valves.
- Sharp edges in combustion chamber.



Check rod and piston alignment when piston shows a diagonal wear pattern extending across the skirt of the piston. Contact with the cylinder wall show on the bottom of the skirt at left and at the ring lands at the right.

A cylinder bored at an angle to the crankshaft can also cause improper ring contact with the cylinder.

This condition causes:

- Rapid piston wear.
- Uneven piston wear.
- Excess oil consumption.



A broken retaining ring caused the damage shown.

Retaining rings loosen or break due to:

- Rod misalignment.
- Excessive crankshaft end play.
- Crankshaft journal taper.
- Weak retaining rings.
- Incorrectly installed retaining rings.

Inertia can cause a broken retaining ring to beat out the piston and cylinder, causing extensive damage.

CRANKSHAFT

Removal/Installation

1. Remove flywheel. (See FLYWHEEL—Removal/Installation on page 3-40.)
1. Remove camshaft. (See CAMSHAFT AND TAPPETS—Removal/Installation on page 3-49.)
2. Remove piston and connecting rod. (See PISTON AND CONNECTING ROD—Removal on page 3-50.)

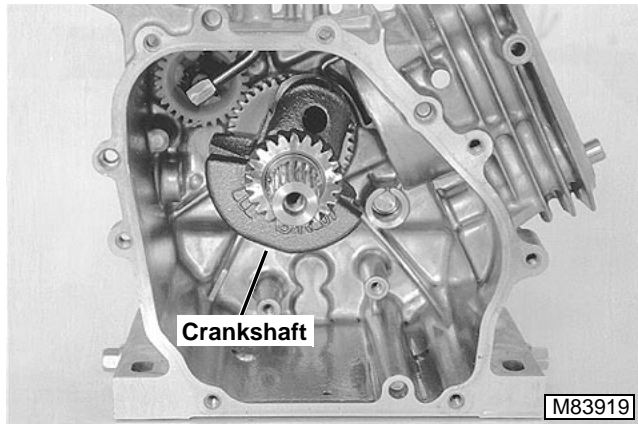

3. Remove crankshaft.
4. Inspect ball bearing in cylinder block. (See CYLINDER BLOCK—Bearing Inspection/Replacement on page 3-60.)
5. Inspect crankshaft for wear or damage. (See Inspection procedure.)

Inspection

1. Analyze crankshaft and connecting rod wear. (See ANALYZE CRANKSHAFT AND CONNECTING ROD WEAR on page 3-59).

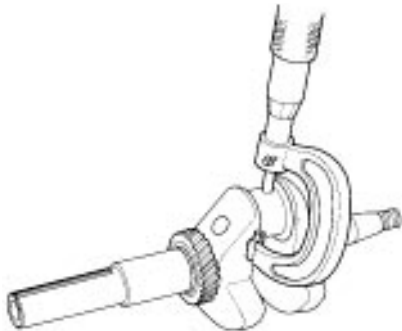

2. Measure connecting rod journal. Replace crankshaft if journal diameter is less than **25.92 mm (1.020 in.)**
3. Check Connecting Rod-to-Crankshaft Clearance. (See Check Connecting Rod-to-Crankshaft Clearance on page 3-55.)
4. Check Connecting Rod Side Play. (See Check Connecting Rod Side Play on page 3-55.)

5. Inspect timing and governor drive gears for wear or damage. Replace if necessary. (See Timing/Governor Gear Replacement procedure.)

Timing/Governor Gear Replacement

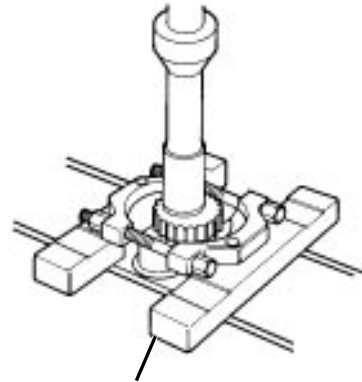

Knife-Edge Puller

NOTE: The removal/installation procedure is identical for both the timing and governor gears.

1. Mark a reference line on the timing/governor gear and crankshaft.
2. Using a knife-edged puller, press the gear off the crankshaft.
3. Using the old gear as a reference, mark the new gear in the same position as the old gear.

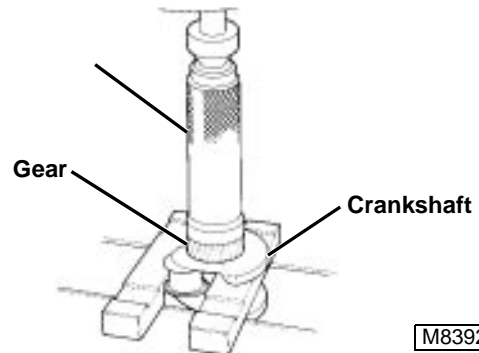

4. Support the crankshaft as shown.
5. Place the gear on the crankshaft and align the marks on the gear and crankshaft.
6. Using driver, press gear on crankshaft until fully seated.

ANALYZE CRANKSHAFT AND CONNECTING ROD WEAR

Check connecting rod and cap for damage or unusual wear patterns.

Lack of lubrication or improper lubrication can cause the connecting rod and cap to seize the crankshaft, the connecting rod and piston may both break causing other internal damage. Inspect block carefully before rebuilding engine.

Crankshaft and connecting rod damage can also result from:

- Engine run low on oil or without oil.
- Oil not changed regularly.
- Bearing cap installed incorrectly.

CYLINDER BLOCK

Inspection

1. Clean block and check for cracks.

NOTE: Cracks not visible to the eye may be detected by coating the suspected area with a mixture of 25% kerosene and 75% light engine oil. Wipe area dry and immediately apply coating of zinc oxide dissolved in wood alcohol. If crack is present, coating becomes discolored at the defective area. Replace block if any cracks are found.

A bare block is available for service.

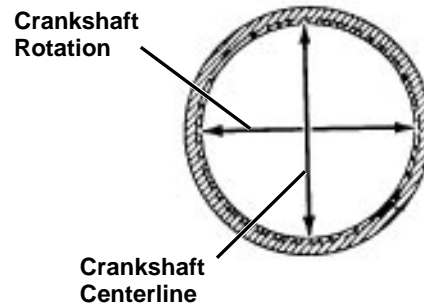
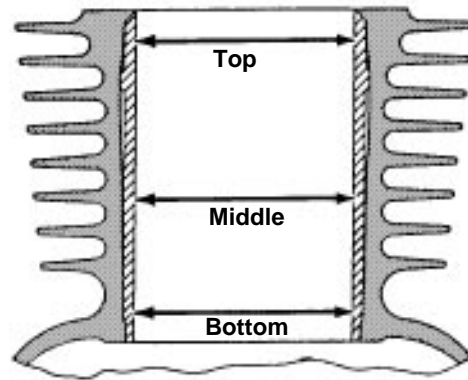

2. Measure cylinder bore diameter at three positions; top, middle and bottom. At these three positions, measure in both directions; along the crankshaft centerline and in the direction of crankshaft rotation.

NOTE: If the engine has had a previous major overhaul, oversize pistons and rings may have been installed. Pistons are available in 0.25 mm (0.010 in.) and 0.50 mm (0.020 in.) oversize.

Cylinder Bore I.D.:

Standard Piston

Standard 60.0 mm (2.36 in.)
Wear Limit. 60.165 mm (2.3687 in.)

0.25 mm (0.010 in.) Oversize Piston

Standard 60.25 mm (2.37 in.)
Wear Limit. 60.415 mm (2.3787 in.)

0.50 mm (0.020 in.) Oversize Piston

Standard 60.5 mm (2.41 in.)
Wear Limit. 60.665 mm (2.3887 in.)

Bearing Inspection/Replacement

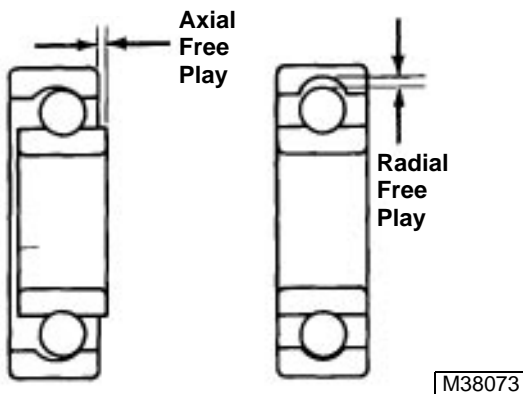
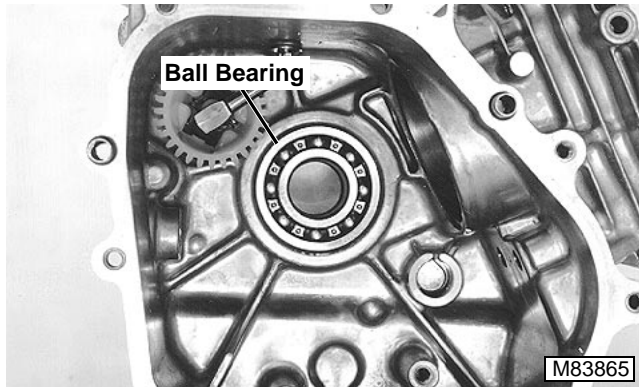

1. Spin bearing by hand and check for axial and/or radial free play. Replace bearing if it has excessive play or is noisy.

NOTE: Remove bearing only if replacement is required.

2. Remove oil seal.
3. Remove bearing using a driver set.
4. Apply a light coat of clean engine oil to bearing outer race.
5. Install bearing using driver set until fully seated against crankcase casting.
6. Install new oil seal

Oil Seal Replacement



7. Remove worn or damaged oil seal using a screwdriver.
8. Pack lithium-based grease inside lips of seal.
9. Install seal with lip toward inside of crankcase using a seal driver set.

Deglaze Cylinder Bore

1. Deglaze cylinder bore using a rigid hone with a 220 to 300 grit stone.
2. Use hone as instructed by manufacturer to obtain a 45° crosshatch pattern.

IMPORTANT: DO NOT use gasoline, kerosene or commercial solvents to clean cylinder bore. Solvents will not remove all abrasives from cylinder walls.

3. Clean cylinder walls using clean white rags and warm soapy water. Continue to clean cylinder until white rags show no discoloration.
4. Dry cylinder and apply a light coat of clean engine oil.

Rebore Cylinder Block

IMPORTANT: Check stone for wear or damage. Use correct stone for the job.

NOTE: The cylinder can be rebored to use 0.25 mm (0.010 in.), and 0.50 mm (0.020 in.) oversize piston and rings. Have a reliable repair shop rebore the block, or use a drill press and honing tool.

Rebore cylinder with a honing tool to initial and final bore specifications.

1. Align center of bore to drill press center.
2. Lower and raise hone until end extends 20—25 mm (0.75—1.0 in.) past end of cylinder.
3. Adjust hone stones until they contact the narrowest point of the cylinder walls.
4. Coat the inside of cylinder with honing oil. Turn hone by hand. Adjust if too tight.
5. Run drill press between 200—250 rpm. Move hone up and down in cylinder approximately 20 times per minute.

NOTE: Measure bore when cylinder is cool.

6. Stop press and check cylinder diameter.

NOTE: Finish should not be smooth. It should have a 40°—60° cross-hatch pattern.

7. Check bore for size, taper and out of round.

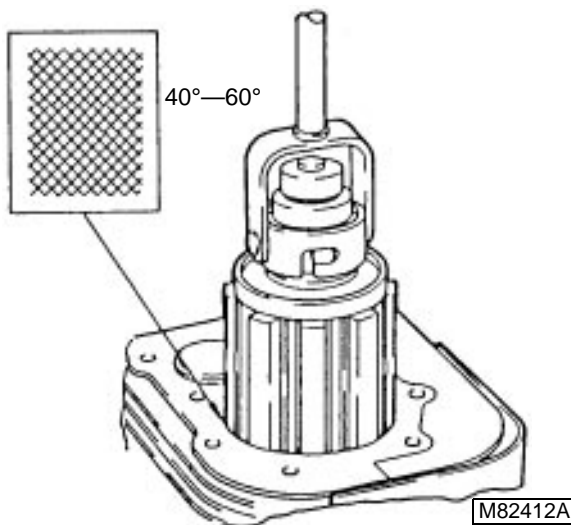

8. If cylinder bore exceeds wear limit, rebore cylinder or replace block.
9. Hone the cylinder an additional 0.007—0.009 mm (0.0003—0.0004 in.) for final bore specifications. This allows for 0.020 mm (0.0008 in.) shrinkage when cylinder cools.

IMPORTANT: DO NOT use gasoline, kerosene or commercial solvents to clean cylinder bore. Solvents will not remove all abrasives from cylinder walls.

10. Clean cylinder walls using clean white rags and warm soapy water. Continue to clean cylinder until white rags show no discoloration.
11. Dry cylinder and apply a light coat of clean engine oil.

GOVERNOR

Removal/Installation

1. Remove crankshaft. (See CRANKSHAFT—Removal/Installation on page 3-58.)

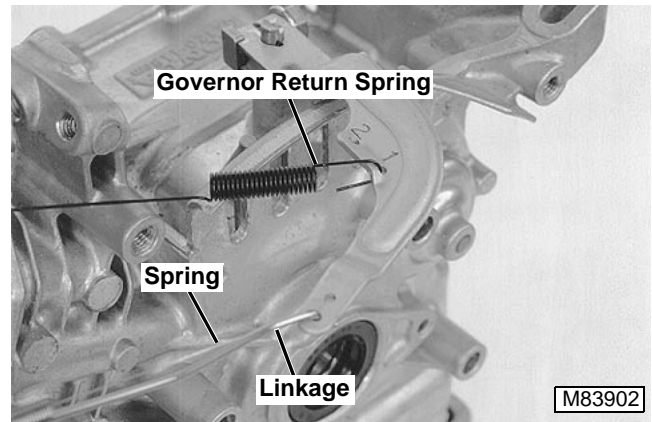

2. Remove governor return spring.
3. Remove linkage and spring.

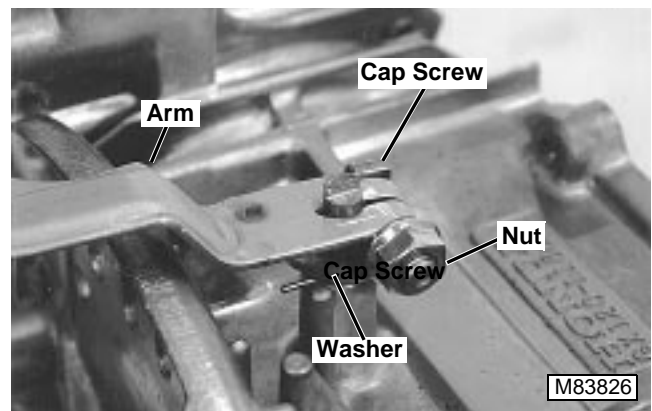

4. Remove nut and screw.
5. Remove governor arm and washer.

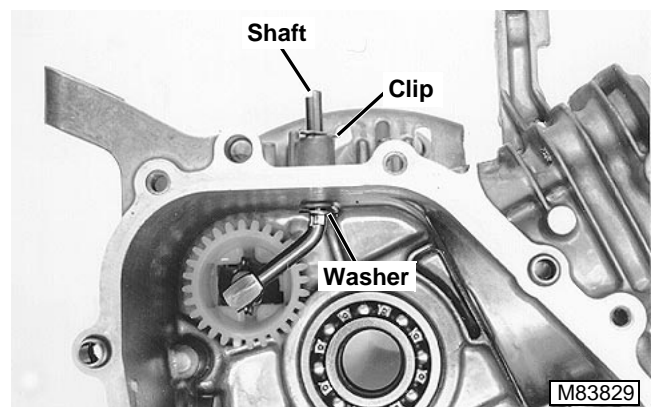

6. Remove clip, governor arm shaft and washer.

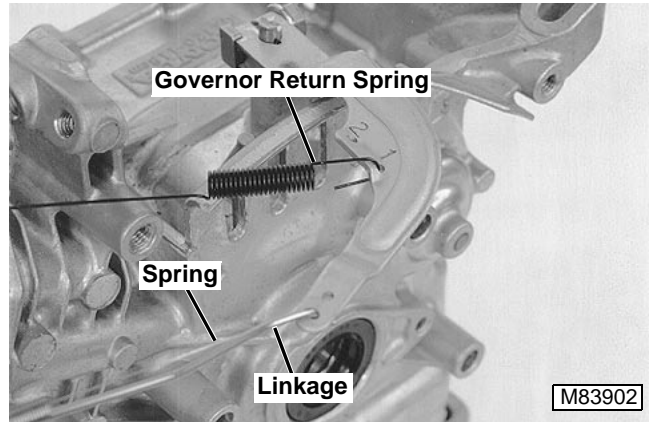
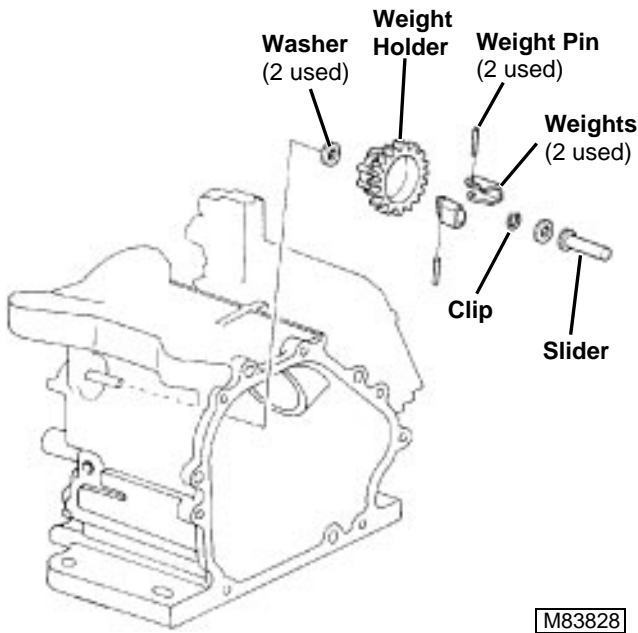

- Install governor spring in hole marked "1".
- Adjust governor. (See GOVERNOR/FAST IDLE SPEED ADJUSTMENT on page 3-23.)

7. Spread governor weights and remove slider.
8. Remove washer.
9. Remove clip and governor weight holder.
10. Remove washer.
11. Remove pins and weights if necessary.
12. Inspect all parts for wear or damage. Replace parts as needed.

Installation is done in the reverse order of removal.

- Check to make sure governor weights move freely.
- Insert clip firmly into shaft groove.
- Check to make sure slider moves freely

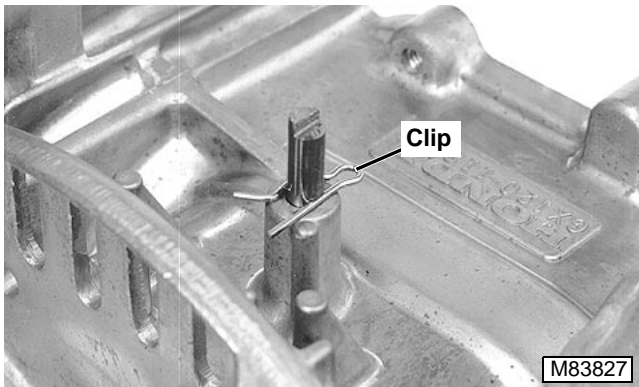

- Position shaft over governor slider, and install clip with straight side of clip against the groove in shaft.

CONTENTS

Page

ELECTRICAL

THEORY AND DIAGNOSTIC INFORMATION

THEORY OF OPERATION INFORMATION	4-2
DIAGNOSTIC INFORMATION	4-2
WIRE COLOR ABBREVIATION CHART	4-2
READING ELECTRICAL SCHEMATICS	4-3

COMPONENT LOCATION4-4

ELECTRICAL SCHEMATIC4-5

WIRING HARNESS.....4-6

TROUBLESHOOTING CHART.....4-7

CIRCUIT OPERATION AND DIAGNOSIS

IGNITION CIRCUIT OPERATION	4-8
IGNITION CIRCUIT OPERATION—ENGINE SHUTTING OFF	4-10
IGNITION CIRCUIT DIAGNOSIS	4-12

TESTS

COMMON CIRCUIT TESTS	4-14
FLYWHEEL MAGNET TEST	4-14
RUN/OFF SWITCH TEST	4-15

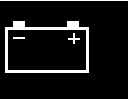

THEORY AND DIAGNOSTIC INFORMATION

THEORY OF OPERATION INFORMATION

The theory of operation stories divide the electrical system into individual circuits by function. Each circuit is isolated from the main wiring schematic and only shows the components that are used in it. The story contains information on function, operating conditions, and theory of operation. The circuit schematics are drawn with the components in the operating position, with the power, or battery positive, into them across the top and the ground, or battery negative, across the bottom.



DIAGNOSTIC INFORMATION

The diagnostic procedures is used to test the complete circuit regardless of the problem or complaint. Select a symptom or system from the quick check or troubleshooting chart and follow the test procedures under that heading.

The diagnostic procedure lists:

- Test conditions
- Test sequence
- Test location
- Normal reading
- Check or test to perform if reading is not normal

When performing the test or check, be sure to set your machine up to the test conditions listed and follow the sequence carefully. The middle “**NORMAL**” column gives the reading or condition that should be obtained when performing the test or check. If the results of the test or check are not normal, perform the test, check, or adjustment listed in the third “**IF NOT NORMAL**” column to repair the malfunction. The detailed tests or adjustments referred to in the “**IF NOT NORMAL**” column are located at the end of that group. The system diagram that accompanies each test procedure is drawn to resemble machine components. The key number on the art matches the number in the “**TEST LOCATION**” column and the leader line points to the exact point the test is to be made.

WIRE COLOR ABBREVIATION CHART

Blk	Black
Blu	Blue
Brn	Brown
Grn	Green
Gry	Gray
Org	Orange
Pnk	Pink
Pur	Purple
Red	Red
Tan	Tan
Wht	White
Yel	Yellow
Blk/Wht	Black/White
Blu/Wht	Blue/White
Brn/Wht	Brown/White
Brn/Yel	Brown/Yellow
Dk Blu	Dark Blue
Dk Brn/Lt Grn	Dark Brown/Light Green
Dk Brn/Red	Dark Brown/Red
Dk Brn/Yel	Dark Brown/Yellow
Dk Grn	Dark Green
Lt Blue	Light Blue
Lt Grn	Light Green
Org/Wht	Orange/White
Pnk/Blk	Pink/Black
Pur/Wht	Purple/White
Red/Blk	Red/Black
Red/Wht	Red/White
Wht/Blk	White/Black
Wht/Red	White/Red
Yel/Blk	Yellow/Black
Yel/Red	Yellow/Red
Yel/Wht	Yellow/White

COMPONENT LOCATION

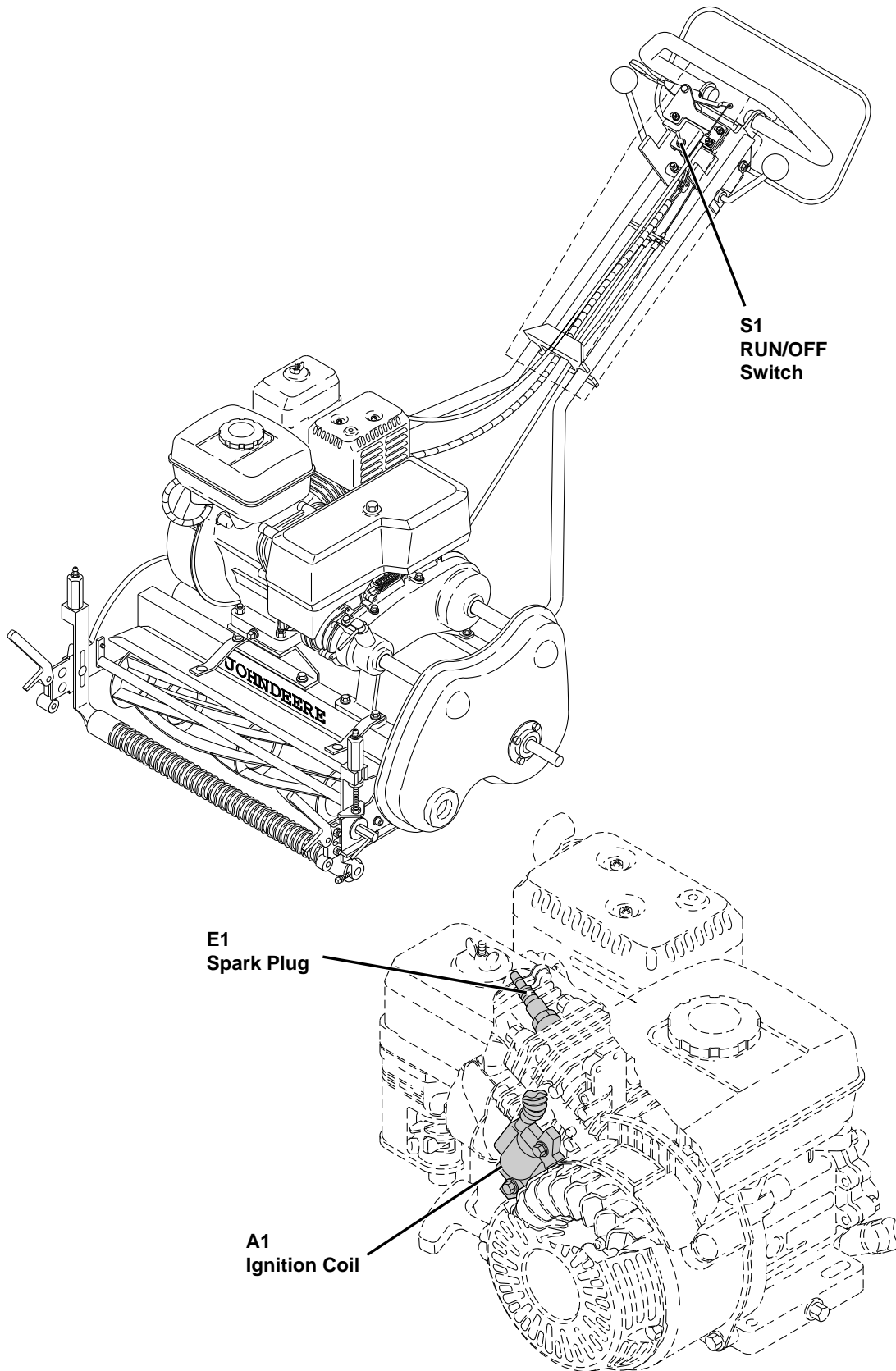
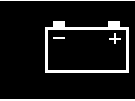

M83948

ELECTRICAL SCHEMATIC

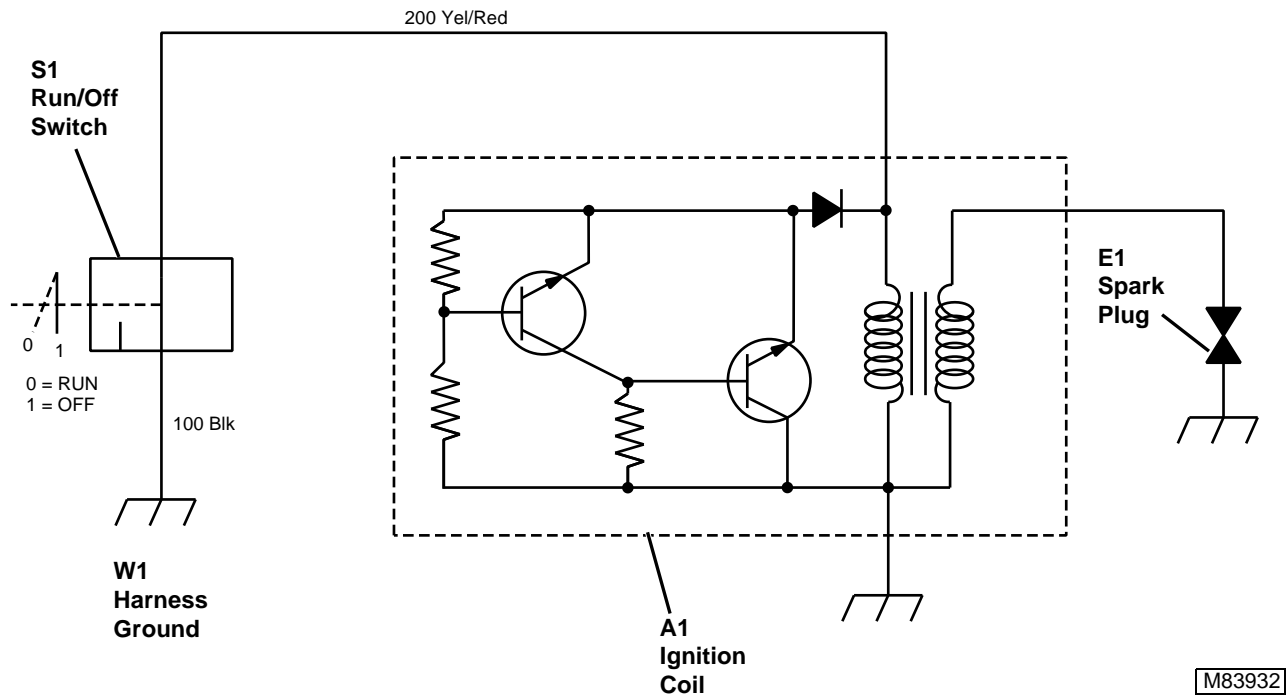

WIRING HARNESS

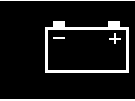
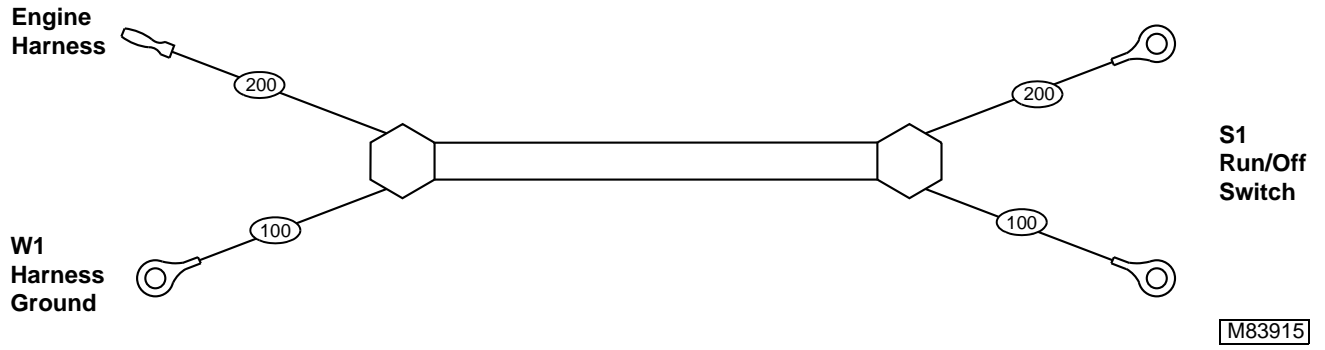

TROUBLESHOOTING

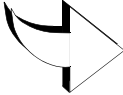
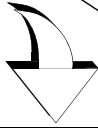
Problem or Symptom  Check or Solution 	No spark.	Engine will not shut off.									
Check ground circuit.	●										
See Ignition circuit diagnosis.		●									

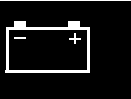

CIRCUIT OPERATION AND DIAGNOSIS

IGNITION CIRCUIT OPERATION

Function:

To create a spark that ignites that fuel/air mixture in the engine.

Operating Conditions:



- RUN/OFF switch in RUN position.

Theory of Operation

The ignition system is a transistor-controlled magneto design. There are no moving parts and there is no need for an external power source (battery). The power and triggering signal are both generated by a permanent magnet on the outside edge of the flywheel, is therefore not adjustable. The engine is shut off by grounding the ignition coil through the RUN/OFF switch.

The ignition coil consists of an iron core with two sets of wires wound around it. The primary winding is connected to As the flywheel turns, the permanent magnet on the flywheel aligns with the ignition coil and produces current in the primary coil by electromagnetic induction.

In the initial stage low voltage current is produced. The low voltage current flows through resistor "A" to the base of transistor "A", causing it to open and allows current to build in the primary coil windings (primary coil current flow). Resistor "B" has high resistance, so current will be prevented from flowing to the base of transistor "B".

In the second stage (spark produced), the flywheel current flow is increased. The current can now flow through the resistor "B" to the base of transistor "B". Transistor "B" is now energized which causes transistor "A" to open. Current then flows through transistor "B" (Primary coil secondary current flow). A voltage of several hundred volts is then produced in the primary coil windings by electromagnetic induction.

The high voltage current flows through the coil wire to the spark plug. The voltage is now high enough to jump the spark plug gap and a spark is produced, igniting the fuel/air mixture in the cylinder.

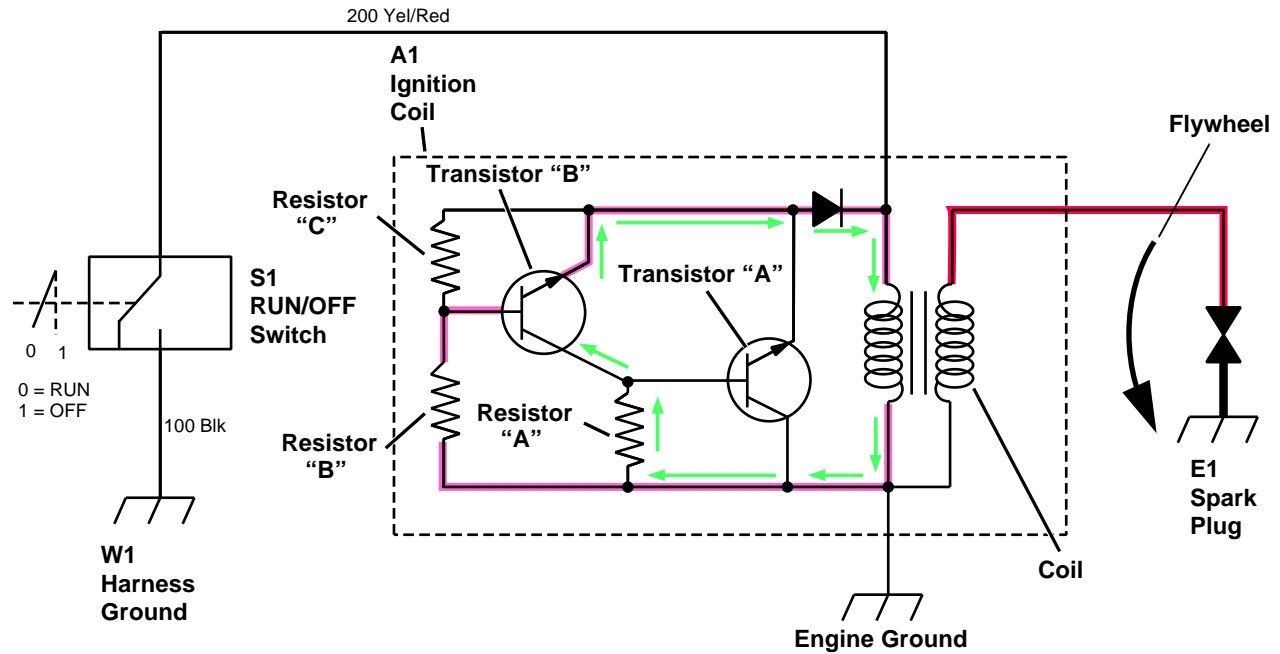
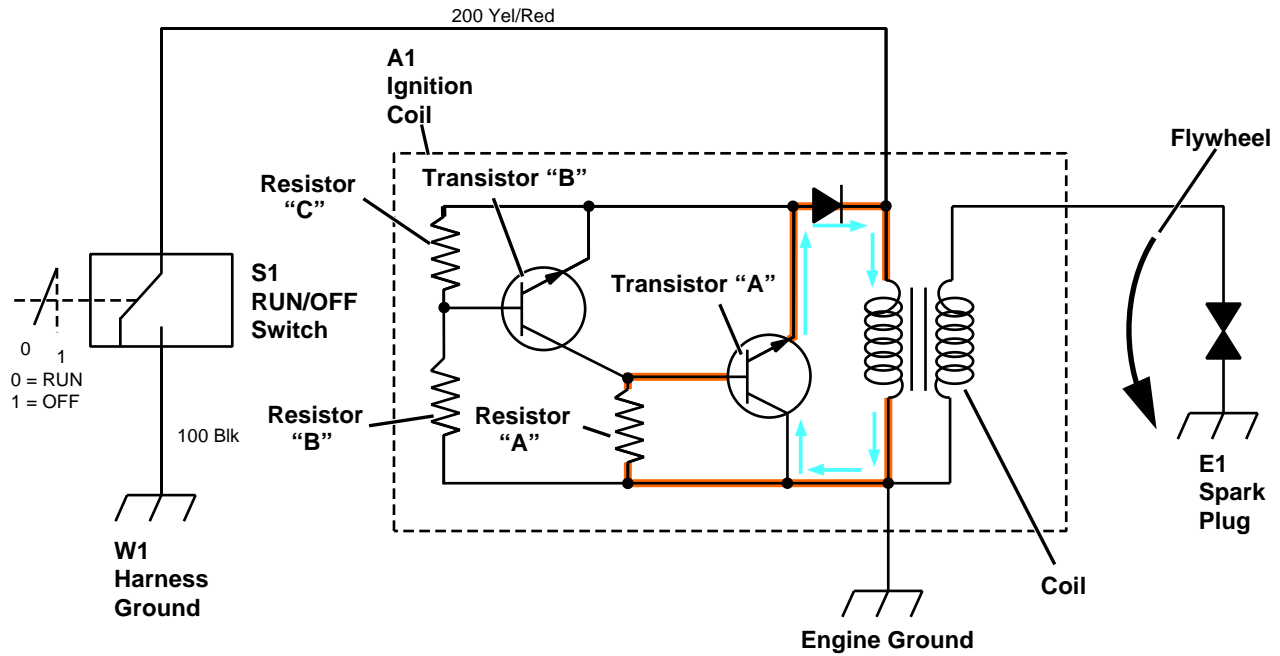

- Low Voltage Primary Circuit
- Primary Coil Current Flow
- Low Voltage Secondary Circuit
- Ground Circuit
- Primary Coil Secondary Current Flow
- High-Voltage Coil Circuit

M83935

IGNITION CIRCUIT OPERATION— ENGINE SHUTTING OFF

Function:

To shut the engine off by grounding the ignition coil through the RUN/OFF switch.

Operating Conditions:

- RUN/OFF switch in OFF position.

Theory of Operation

When the RUN/OFF switch is moved to the OFF position, a path to ground is provided through the switch. This prevents voltage from building up in the coil primary windings, preventing a spark from being generated.



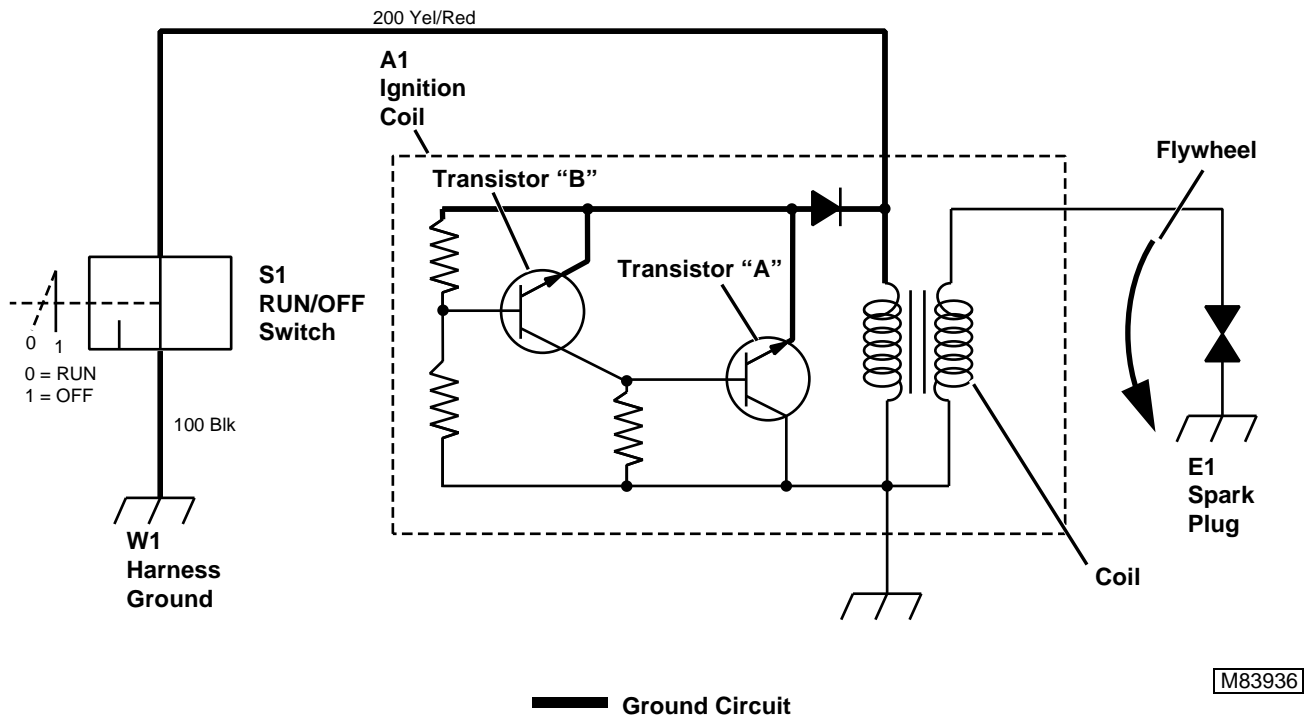

IGNITION CIRCUIT DIAGNOSIS

When diagnosing an ignition problem, isolate the magneto circuit from the ground circuit by disconnecting the RUN/OFF switch connectors. If the engine will not start, check the magneto circuit first and then the ground circuit. If the engine will not shut off, check the ground circuit first. Remember the engine is stopped by grounding the ignition coil through the RUN/OFF switch.

Test Conditions:

- RUN/OFF switch in RUN position.
- Travel clutch in NEUTRAL position.
- Check connection(s) for corrosion and looseness when checking/testing.

Test/Check Point	Normal	If Not Normal
1. Spark plug/spark tester (See SPARK TEST on page 3-25.)	Spark test indicates hot, blue spark.	No Spark present: Test ignition coil. (See IGNITION COIL—Test on page 3-40.) Check armature air gap. (See IGNITION COIL—Air Gap Adjustment on page 3-39.) Check flywheel magnet. (See FLYWHEEL MAGNET TEST on page 4-14.)
		Spark present: Check spark plug condition and gap. (See SPARK PLUG GAP ADJUSTMENT on page 3-26.) If plug is good, continue checking ground circuit.

Test Conditions:

- RUN/OFF switch in OFF position.
- Ohmmeter (or continuity tester) lead connected to Yel/Red wire No. 200 at engine connector.

Test/Check Point	Normal	If Not Normal
2. RUN/OFF switch—Terminal No. 2.	Maximum 0.1 ohms resistance.	Replace wire harness.
3. RUN/OFF switch—Terminal No. 3.	Maximum 0.1 ohms resistance.	Test RUN/OFF switch. (See RUN/OFF SWITCH TEST on page 4-15.)
4. Engine ground.	Maximum 0.1 ohms resistance.	Replace wire harness.

Test Conditions:

- RUN/OFF switch in RUN position.

Test/Check Point	Normal	If Not Normal
5. RUN/OFF switch—Terminal No. 3.	No continuity. (High resistance.)	Test RUN/OFF switch. (See RUN/OFF SWITCH TEST on page 4-15.)

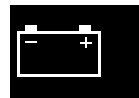
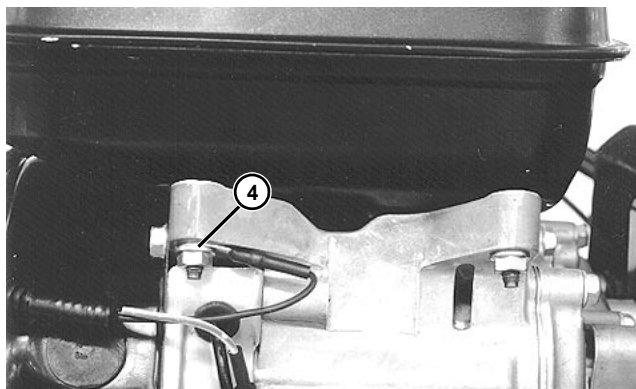
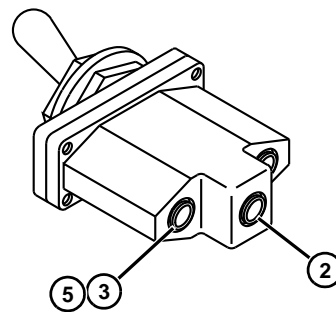
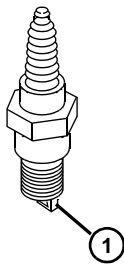

TESTS

COMMON CIRCUIT TESTS

Shorted Circuit:

A shorted circuit may result in the wrong component operating (i.e. improper wire-to-wire contact). To test for a shorted or improperly wired circuit:

1. Turn component switch ON.
2. Start at the controlling switch of the component that should not be operating.
3. Follow the circuit and disconnect wires at connectors until component stops operating.
4. Shorted or improper connections will be the last two wires disconnected.

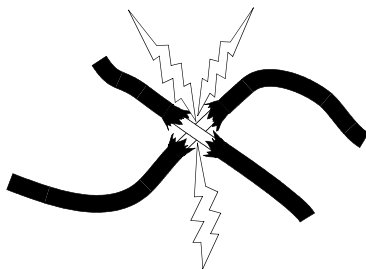

M85600

High Resistance or Open Circuit:

High resistance or open circuits usually result in slow, dim or no component operation (i.e. poor, corroded, or disconnected connections). Voltage at the component will be low when the component is in operation. To test for high resistance and open circuits:

1. Check all terminals and grounds of the circuit for corrosion.
2. If terminals are not corroded or loose, the problem is in the component or wiring.



M85601

Grounded Circuit:

Grounded circuits usually result in no component operation or a blown fuse.

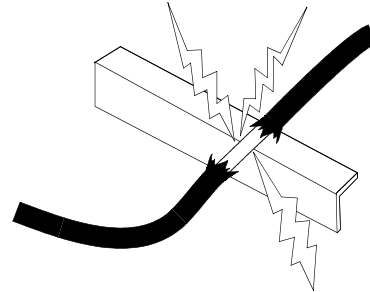

M85602

FLYWHEEL MAGNET TEST

Reason:

To make sure the flywheel magnet has enough force to induce current in the ignition coil.

Procedure:

1. Park machine on a level surface.
2. Move RUN/OFF switch to OFF position.
3. Engage park brake.
4. Remove blower housing. (See BLOWER HOUSING ASSEMBLY—Removal/Installation on page 3-36.)

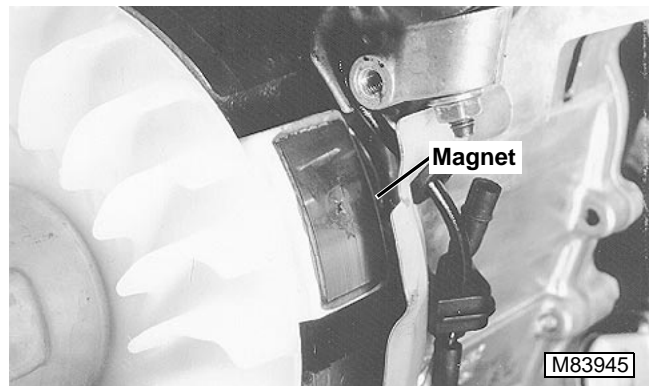

5. Hold a steel tool about 25 mm (1.0 in.) from flywheel magnet. The tool should be attracted by the magnet.

Result:

- Replace the flywheel if the magnet does not attract tool.

RUN/OFF SWITCH TEST

Reason:

To make sure the RUN/OFF switch is operating properly.

Test Equipment:

- Ohmmeter or continuity tester.

Procedure:

1. Park machine on a level surface.
2. Move RUN/OFF switch to OFF position.
3. Engage park brake.
4. Disconnect wires from switch.

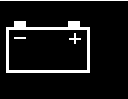
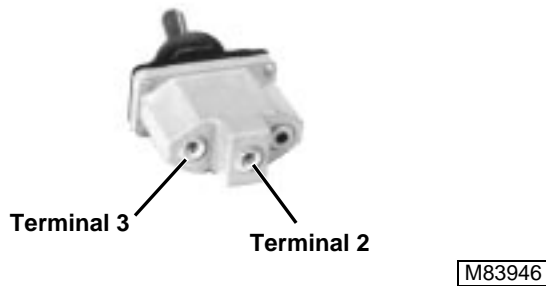

5. Move switch to RUN position.
6. Check continuity across terminals 2 and 3. There should be no continuity.
7. Move switch to OFF position.
8. Check continuity across terminals 2 and 3. There should be continuity.

Results:

- If continuity is not correct, replace switch.



This page intentionally left blank.

CONTENTS

Page

POWER TRAIN

SPECIFICATIONS

ADJUSTMENT SPECIFICATIONS	5-2
REPAIR SPECIFICATIONS.....	5-2

COMPONENT LOCATION AND OPERATION

DRIVE BELT/SPEED REDUCTER SYSTEM	5-3
--	-----

TROUBLESHOOTING

POWER TRAIN TROUBLESHOOTING CHART.....	5-4
--	-----

DIAGNOSIS

MACHINE WILL NOT DRIVE	5-5
NOISY OPERATION	5-6
MACHINE DOES NOT REACH FULL GROUND SPEED.....	5-7
ERRATIC SPEED	5-7
PARK BRAKE DOES NOT HOLD MACHINE	5-8
TRACTION DRIVE PULLS TO ONE SIDE	5-9

CHECKS AND ADJUSTMENTS

DRIVE BELT TENSION CHECK AND ADJUSTMENT	5-10
BELT GUIDE ADJUSTMENT	5-11
TRACTION ROLLER ADJUSTMENT	5-11
TRANSPORT ROLLER DRIVE CHAIN TENSION ADJUSTMENT.....	5-13

REPAIR

CLUTCH CONTROL CABLE.....	5-14
DRIVE BELT REPLACEMENT	5-14
SPEED REDUCER ASSEMBLY	
Removal/Installation	5-15
Disassembly/Inspection	5-17
Assembly	5-20
TRACTION ROLLER ASSEMBLY	
Removal/Installation	5-22
Disassembly/Assembly.....	5-25
DRIVE CHAIN TENSIONERS.....	5-26
DRIVE BELT IDLER BRACKET ASSEMBLY	5-27



SPECIFICATIONS

ADJUSTMENT SPECIFICATIONS

- Drive Belt-to-Guide Clearance (Clutch ENGAGED) 1 mm (0.040 in.)
- Transport Roller Drive Chain-Maximum Deflection11 mm (7/16 in.)

REPAIR SPECIFICATIONS

- Speed Reducer Oil Capacity 0.5 L (0.5 qt)
- Traction Roller Eccentric Nut Torque 22 N•m (16 lb-ft)

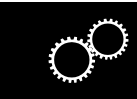

COMPONENT LOCATION AND OPERATION

DRIVE BELT/SPEED REDUCER SYSTEM

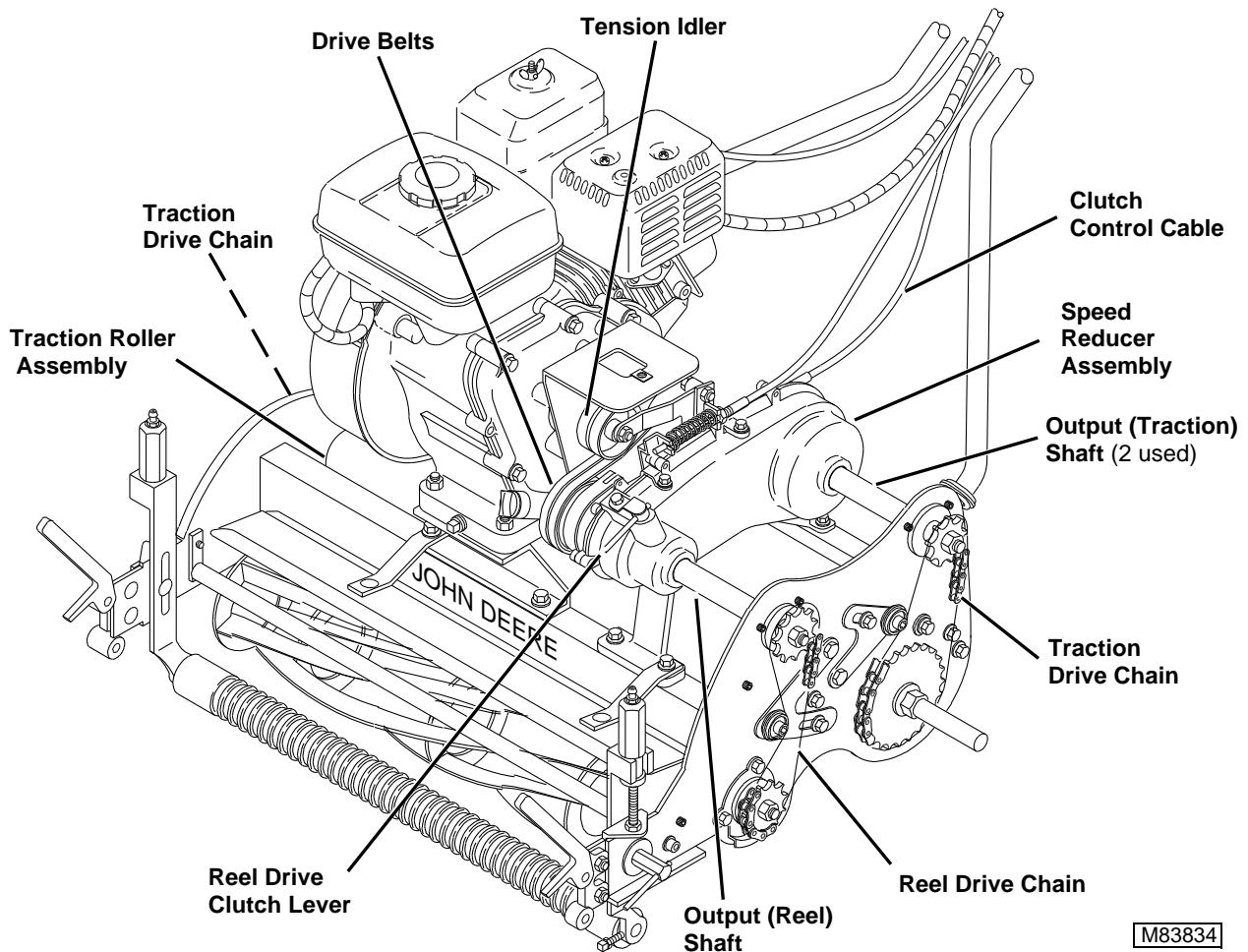
**Function:**

To transmit power to the reel and transport roller assembly. The speed reducer assembly also features a differential assembly to assist in turning.

Theory of Operation:

The speed reducer is connected to the engine by two V-belts. When the travel clutch lever is moved to the ENGAGED position, the cable pulls the tension idler down against the belts, applying tension to the drive belts.

As tension is applied to the belts, the speed reducer input sheave/shaft turns and power is transferred to the differential assembly by way of a chain.

Output (traction) shafts connected to the differential transfer power to the transport roller assembly by way of chain drives on each side of the mower.

The transport roller assembly consists of two independently-driven aluminum rollers. As the mower is turned, the speed reducer differential allows the rollers to turn at different speeds, allowing the mower to turn smoothly.

The speed reducer also drives the cutting unit reel. The reel drive can be disengaged when transporting the mower, by placing the reel drive clutch in the STOP position.

When the reel drive clutch is moved to the MOW position, a ramped clutch is engaged with the input shaft assembly, transferring power to the cutting reel by a chain drive.

TROUBLESHOOTING

POWER TRAIN TROUBLESHOOTING CHART

	Machine will not drive.	Drive train noisy.	Machine does not achieve full ground speed.	Erratic speed	Park brake does not hold machine.	Traction drive pulls to one side.
Engine drive sheave and/or key damaged or missing.	●					
Wrong oil in speed reducer.		●				
Drive belts broken, worn or out of adjustment.	●		●	●		
Clutch cable out of adjustment or damaged.	●		●			
Speed reducer input shaft assembly damaged.	●				●	
Speed reducer input shaft key damaged or missing.	●				●	
Speed reducer chain broken and/or input shaft/differential sprockets damaged.	●	●			●	
Differential gears damaged.	●	●			●	●
Speed reducer bearing(s) worn, binding or damaged.		●	●			●
Traction drive chain(s) loose.		●		●		●
Traction drive chain(s) broken.	●				●	●
Speed reducer output shaft drive sprocket(s) and/or key(s) damaged or missing.	●				●	●
Speed reducer output shaft (frame) bearing(s) worn, binding or damaged.		●	●			●
Park brake engaged.	●		●			
Traction drive roller key(s) and/or sprocket(s) damaged or missing.	●				●	●
Traction drive roller bearing(s) worn, binding or damaged.		●	●			●

DIAGNOSIS

MACHINE WILL NOT DRIVE

Test Conditions:

- Machine parked on level surface.
- RUN/OFF switch in OFF position.
- Park brake disengaged.
- Travel clutch disengaged.

Test Location	Normal	If Not Normal
1. Park brake.	Brake not engaged.	Release park brake.
2. Engine drive sheave.	No damage to drive key or keyway, sheave intact with no evidence of wear.	Replace sheave and/or key.
3. Drive belts.	Not broken, worn, frayed, glazed or stretched.	Replace drive belts. (See DRIVE BELT REPLACEMENT on page 5-14.)
	Properly tensioned.	Adjust drive belt tension. (See DRIVE BELT TENSION CHECK AND ADJUSTMENT on page 5-10.)
4. Speed reducer input shaft assembly.	Key not missing or damaged.	Replace key. (See SPEED REDUCER—Disassembly/Inspection on page 5-17.)
	Shaft not damaged.	Replace input shaft. (See SPEED REDUCER—Disassembly/Inspection on page 5-17.)
	Sprocket not damaged.	Replace sprocket. (See SPEED REDUCER—Disassembly/Inspection on page 5-17.)
5. Speed reducer chain.	Not broken.	Replace chain. (See SPEED REDUCER—Disassembly/Inspection on page 5-17.)
6. Differential Assembly	Gears not damaged.	Replace differential gears. (See SPEED REDUCER—Disassembly/Inspection on page 5-17.)
7. Speed reducer output shafts.	Shafts not damaged.	Replace output shaft(s). (See SPEED REDUCER—Disassembly/Inspection on page 5-17.)
	Sprocket keys not damaged or missing.	Replace keys.
8. Traction drive chains	Not broken.	Replace chain(s).
9. Traction drive roller assembly	Keys not missing or damaged.	Replace keys. (See TRACTION ROLLER ASSEMBLY—Disassembly/Assembly on page 5-25.)
	Sprockets not damaged.	Replace sprockets. (See TRACTION ROLLER ASSEMBLY— Disassembly/Assembly on page 5-25.)

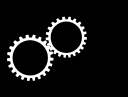

NOISY OPERATION

Test Conditions:

- Machine parked on level surface.
- RUN/OFF switch in OFF position.
- Park brake disengaged.
- Travel clutch disengaged.

Test Location	Normal	If Not Normal
1. Speed reducer dipstick cap. (Check cold.)	Oil between bottom of dipstick and first mark with cap completely turned into threads.	Fill to correct level with oil meeting specifications. (See SPEED REDUCER OIL—NORTH AMERICA or SPEED REDUCER OIL—EUROPE on page 2-10.)
2. Differential Assembly	Gears not damaged.	Replace differential gears. (See SPEED REDUCER—Disassembly/Inspection on page 5-17.)
3. Speed reducer assembly bearings (Input and output shafts).	Bearings not worn or damaged.	Replace bearings. (See SPEED REDUCER—Disassembly/Inspection on page 5-17.)
4. Speed reducer output shaft (frame) bearings.	Bearings not worn or damaged.	Replace bearings. (See FRAME AND DRIVE COVERS on page 9-4.)
5. Traction drive chains.	Chains not loose.	Tighten drive chains. (See TRANSPORT ROLLER DRIVE CHAIN TENSION ADJUSTMENT on page 5-13.)
	Chains properly lubricated.	Apply grease to chains. (See GREASE—NORTH AMERICA or GREASE—EUROPE on page 2-13.)
6. Traction roller assembly.	Bearings not worn or damaged.	Replace bearings (See TRACTION ROLLER ASSEMBLY—Disassembly/Assembly on page 5-25.)

MACHINE DOES NOT REACH FULL GROUND SPEED

Test Conditions:

- Machine parked on level surface.
- RUN/OFF switch in OFF position.
- Park brake disengaged.
- Travel clutch disengaged.

Test Location	Normal	If Not Normal
1. Park brake.	Brake not engaged.	Release park brake.
2. Drive belts.	Not worn, frayed, glazed or stretched.	Replace drive belts. (See DRIVE BELT REPLACEMENT on page 5-14.)
	Properly tensioned.	Adjust drive belt tension. (See DRIVE BELT TENSION CHECK AND ADJUSTMENT on page 5-10.)
3. Speed reducer assembly bearings (Input and output shafts).	Bearings not worn, damaged or binding.	Replace bearings. (See SPEED REDUCER—Disassembly/Inspection on page 5-17.)
4. Speed reducer output shaft (frame) bearings.	Bearings not worn, damaged or binding.	Replace bearings. (See FRAME AND DRIVE COVERS on page 9-4.)
5. Traction roller assembly.	Bearings not worn or damaged.	Replace bearings (See TRACTION ROLLER ASSEMBLY—Disassembly/Assembly on page 5-25.)

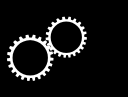

ERRATIC SPEED

Test Conditions:

- Machine parked on level surface.
- RUN/OFF switch in OFF position.
- Park brake disengaged.
- Travel clutch disengaged.

Test Location	Normal	If Not Normal
1. Drive belts.	Not worn, frayed, glazed or stretched.	Replace drive belts. (See DRIVE BELT REPLACEMENT on page 5-14.)
2. Traction drive chains.	Chains not loose.	Tighten drive chains. (See TRANSPORT ROLLER DRIVE CHAIN TENSION ADJUSTMENT on page 5-13.)

PARK BRAKE DOES NOT HOLD MACHINE

Test Conditions:

- Machine parked on level surface.
- RUN/OFF switch in OFF position.
- Park brake disengaged.
- Travel clutch disengaged.

Test Location	Normal	If Not Normal
1. Speed reducer input shaft assembly.	Key not missing or damaged.	Replace key. (See SPEED REDUCER—Disassembly/Inspection on page 5-17.)
	Shaft not damaged.	Replace input shaft. (See SPEED REDUCER—Disassembly/Inspection on page 5-17.)
	Sprocket not damaged.	Replace sprocket. (See SPEED REDUCER—Disassembly/Inspection on page 5-17.)
2. Speed reducer chain.	Not broken.	Replace chain. (See SPEED REDUCER—Disassembly/Inspection on page 5-17.)
3. Differential Assembly	Gears not damaged.	Replace differential gears. (See SPEED REDUCER—Disassembly/Inspection on page 5-17.)
4. Speed reducer output shafts.	Shafts not damaged.	Replace output shaft(s). (See SPEED REDUCER—Disassembly/Inspection on page 5-17.)
	Sprocket keys not damaged or missing.	Replace keys.
5. Traction drive chains	Not broken.	Replace chain(s).
6. Traction drive roller assembly	Keys not missing or damaged.	Replace keys. (See TRACTION ROLLER ASSEMBLY—Disassembly/Assembly on page 5-25.)
	Sprockets not damaged.	Replace sprockets. (See TRACTION ROLLER ASSEMBLY—Disassembly/Assembly on page 5-25.)

TRACTION DRIVE PULLS TO ONE SIDE

Test Conditions:

- Machine parked on level surface.
- RUN/OFF switch in OFF position.
- Park brake disengaged.
- Travel clutch disengaged.

Test Location	Normal	If Not Normal
1. Differential Assembly	Gears not damaged.	Replace differential gears. (See SPEED REDUCER—Disassembly/Inspection on page 5-17.)
2. Speed reducer assembly bearings (output shafts).	Bearings not worn, damaged or binding.	Replace bearings. (See SPEED REDUCER—Disassembly/Inspection on page 5-17.)
3. Speed reducer output shaft (frame) bearings.	Bearings not worn, damaged or binding.	Replace bearings. (See FRAME AND DRIVE COVERS on page 9-4.)
4. Speed reducer output shaft sprocket(s) and/or key(s).	Sprockets not damaged.	Replace sprockets.
	Keys not damaged or missing.	Replace keys.
5. Traction drive chains.	Chains not loose.	Tighten drive chains. G1(See TRANSPORT ROLLER DRIVE CHAIN TENSION ADJUSTMENT on page 5-13.)
	Chains not broken.	Replace drive chain(s).
6. Traction roller assembly.	Bearings not worn or damaged.	Replace bearings (See TRACTION ROLLER ASSEMBLY—Disassembly/Assembly on page 5-25.)
	Sprockets not damaged.	Replace sprockets. (See TRACTION ROLLER ASSEMBLY—Disassembly/Assembly on page 5-25.)
	Keys not damaged or missing.	Replace keys. (See TRACTION ROLLER ASSEMBLY—Disassembly/Assembly on page 5-25.)

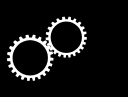

CHECKS AND ADJUSTMENTS

DRIVE BELT TENSION CHECK AND ADJUSTMENT

Reason:

When properly adjusted, with engine OFF and clutch in NEUTRAL, machine should move freely. With clutch ENGAGED, transport roller should not move.

Check Procedure:

1. Park machine on a level surface.
2. Move RUN/OFF switch to OFF position.
3. Move Travel Clutch Lever to NEUTRAL position.
4. Pull the machine backwards, transport wheels/roller turn should turn freely.
 - If transport wheels/roller turn freely, proceed to next step.
 - If transport wheels/roller do not turn, adjust belt tension.
5. Move clutch lever to ENGAGED position.
6. Pull the machine backwards, if transport wheels/roller should not turn.
 - If transport wheels/roller turns, or excessive force is required to engage clutch, adjust belt tension.
 - If transport wheels/roller does not turn, proceed to next step.
7. Move clutch lever to DISENGAGED position.
8. Start engine, the machine should not move forward. If it does, adjust belt tension.

Adjustment Procedure:

NOTE: The drive belt tension should be adjusted just tight enough so that the transport roller does not move when the clutch is engaged. DO NOT over-tighten belt tension.

1. Park machine on a level surface.
2. Move RUN/OFF switch to OFF position.
3. Move Travel Clutch Lever to NEUTRAL position.

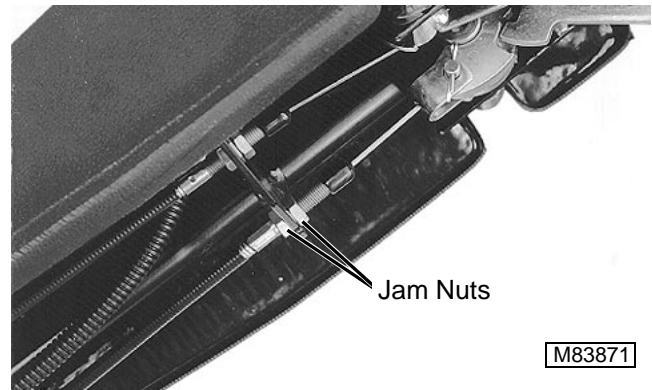

4. Loosen jam nuts (one on each side of bracket).
5. Lengthen or shorten ferrule length to change belt idler tension:
 - Shorten ferrule length to INCREASE tension.
 - Lengthen ferrule length to DECREASE tension.
6. Repeat CHECK procedure. If additional adjustment is required, go to step 7.

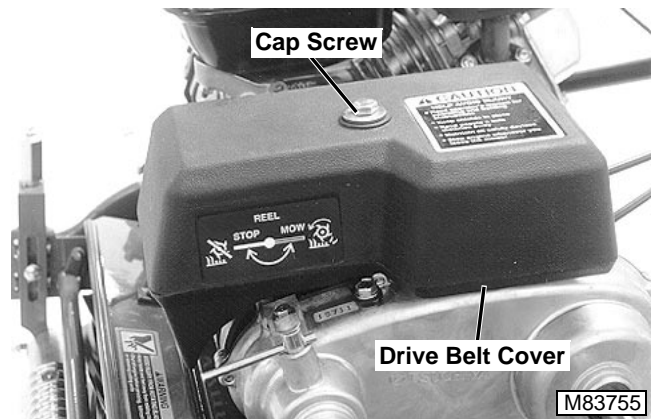

7. Remove cap screw and drive belt cover.

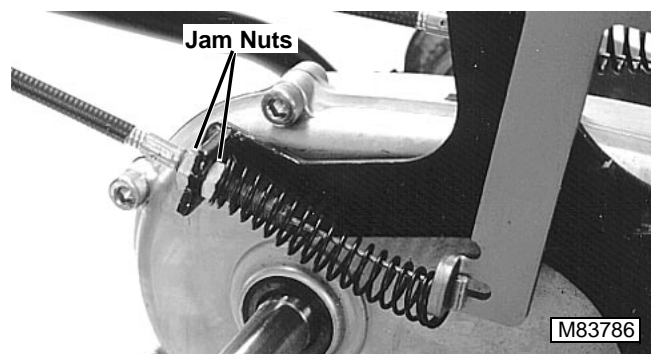

8. Loosen jam nut (one on each side of bracket).
9. Lengthen or shorten ferrule length to change belt idler tension:
 - Shorten ferrule length to INCREASE tension.
 - Lengthen ferrule length to DECREASE tension.
10. Repeat CHECK procedure. If additional adjustment is required, go to step 11.

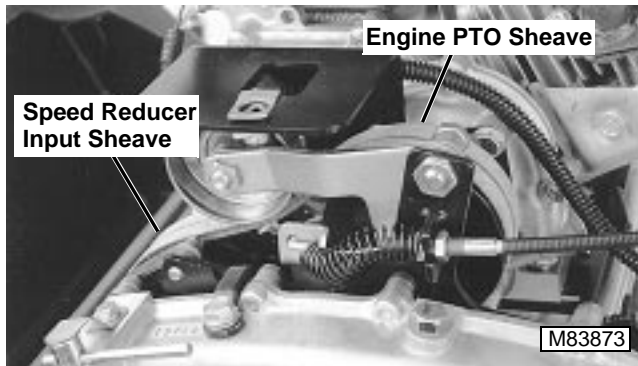

IMPORTANT: Engine PTO sheave and speed reducer input sheave **MUST** align.

11. Loosen engine mounting bolts.
12. Slide engine forward (loosen) or rearward (tighten) to adjust belt tension.
13. Tighten engine mounting bolts.
14. Replace drive belt cover.

DRIVE BELT GUIDE ADJUSTMENT

Reason:

When properly adjusted, the belt guide prevents movement when the clutch is disengaged.

Procedure:

NOTE: The drive belt tension should be properly adjusted before adjusting belt guides. (See DRIVE BELT TENSION CHECK AND ADJUSTMENT on page 5-10.)

1. Park machine on a level surface.
2. Move RUN/OFF switch to OFF position.
3. Move Travel Clutch Lever to ENGAGED position.
4. Engage park brake.

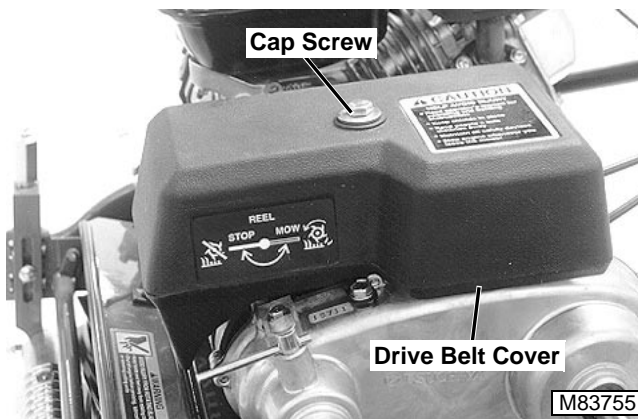

5. Remove cap screw and drive belt cover.

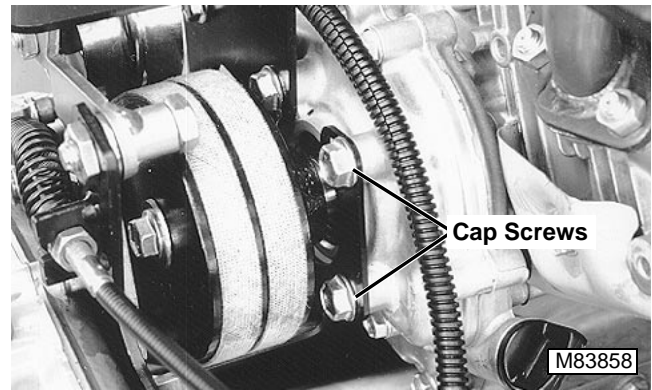

6. Loosen two cap screws, and adjust bracket until there is a **1 mm (0.040 in.)** clearance between belt and guide.
7. Tighten guide mounting bolts.
8. Replace drive belt cover.

TRACTION ROLLER ADJUSTMENT

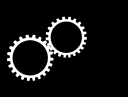

Reason:

In order to ensure an even, level cut, the transport roller must be parallel to the reel.

Equipment:

- #006 Flat Bench Plate
- Feeler Gauge Set (Blade Type)

Procedure:

*NOTE: The cutting height adjustment **MUST** be performed before adjusting transport roller. (See CUTTING HEIGHT ADJUSTMENT on page 8-17.)*

1. Park machine on a level surface.
2. Move RUN/OFF switch to OFF position.
3. Move Travel Clutch Lever to NEUTRAL position.
4. Engage park brake.
5. Remove grass catcher.
6. Remove transport wheels and and right drive collar (if equipped). (See TRANSPORT WHEELS on page 9-3.)

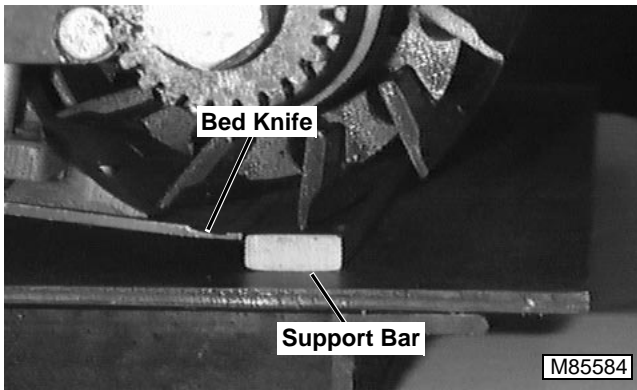

7. Place the machine on a #006 flat bench plate so that the bed knife contacts the rear edge of the support bar.

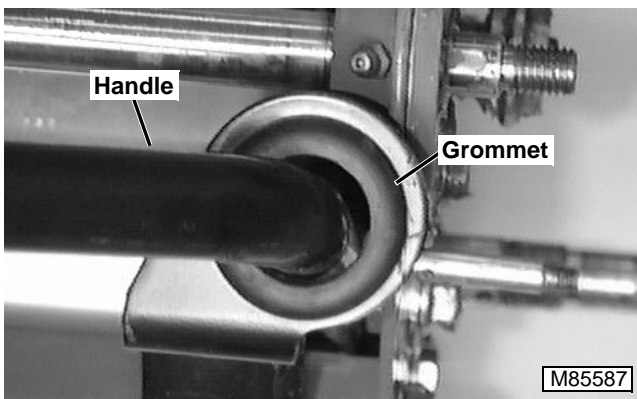

8. Support the handlebars so that they are centered in the grommets. DO NOT lift the transport roller off bench plate.

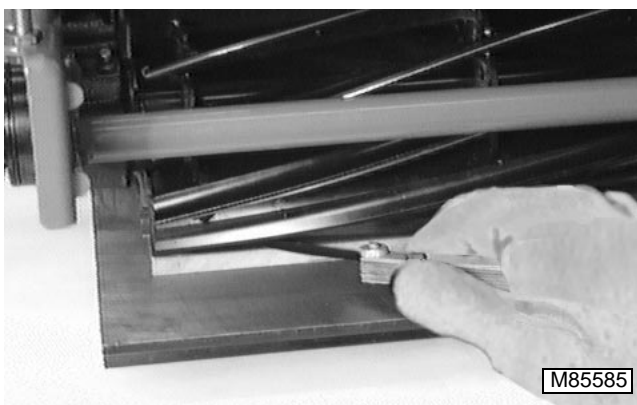

9. Check gap at each end of front roller. If gap is **0.1 mm (0.004 in.) or less**, no adjustment is necessary. If adjustment is require, proceed to step 10.

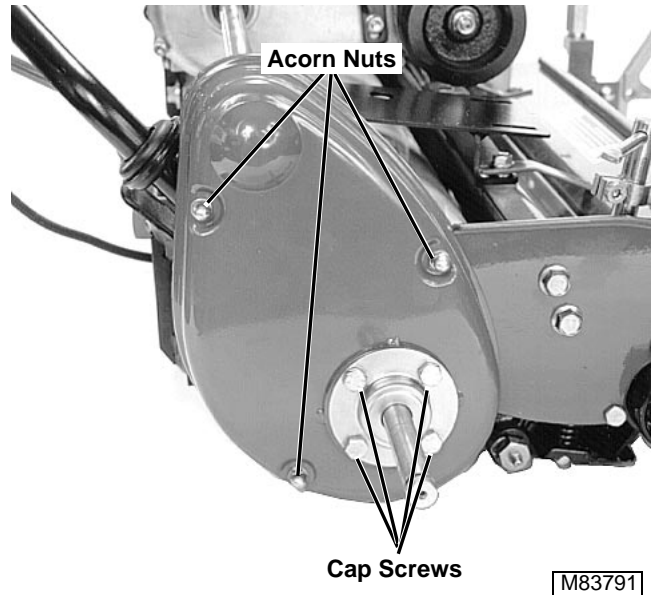

10. Loosen four bearing housing cap screws.
11. Remove three acorn nuts, washers and shoulder bolts, and remove right drive cover.

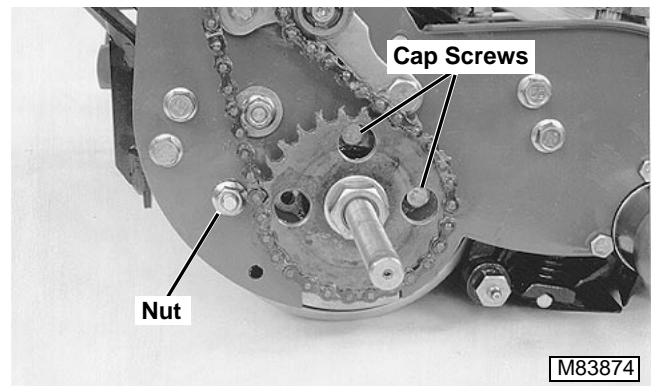

12. Rotate roller until holes in sprocket align with bearing holder cap screws. Loosen two cap screws.
13. Loosen nut attached to eccentric screw.

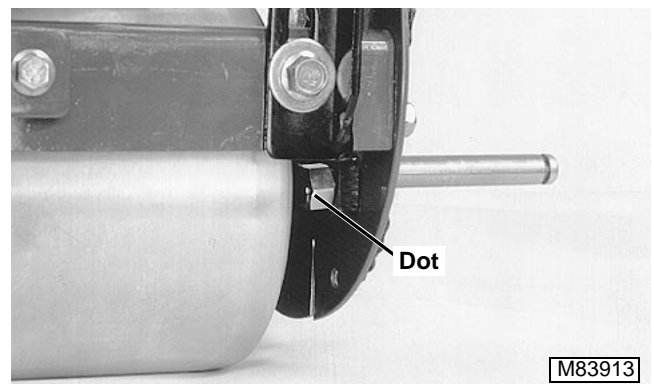

14. Position eccentric dot at position as shown. Rotate eccentric until gap at ends of front roller is less than **0.1 mm (0.004 in.)**.

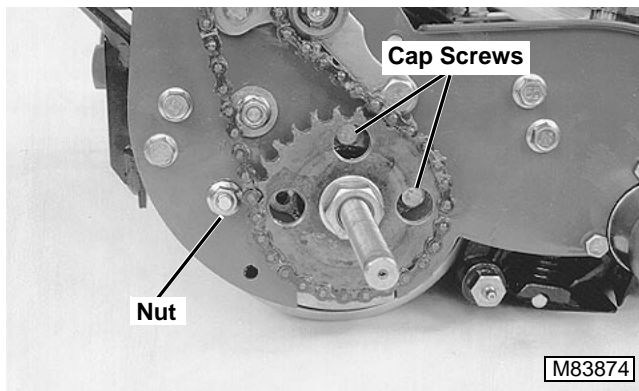

15. Tighten eccentric screw and nut and bearing holder cap screws and eccentric screw and nut to **22 N•m (16 lb-ft)**.
16. Install drive cover.
17. Install transport wheels and drive collars (if equipped). (See TRANSPORT WHEELS on page 9-3.)

TRANSPORT ROLLER DRIVE CHAIN TENSION ADJUSTMENT

Reason:

To maintain proper chain tension.

Procedure:

CAUTION

Block machine securely before servicing or repairing.

1. Park machine on a level surface.
2. Move RUN/OFF switch to OFF position.
3. Move Travel Clutch Lever to NEUTRAL position.
4. Engage park brake
5. Remove transport wheels and left side drive collar (if equipped). (See TRANSPORT WHEELS on page 9-3.)

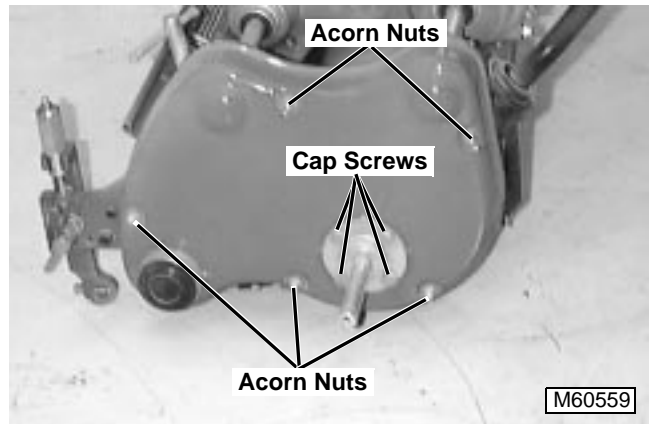

6. Loosen four bearing housing cap screws.
7. Remove five acorn nuts, washers and shoulder bolts, and remove left drive cover.

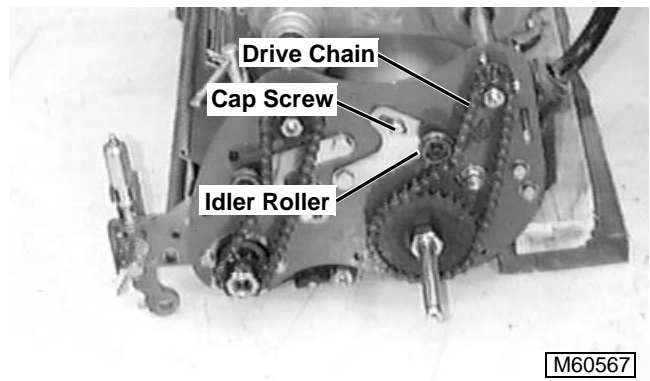

8. Loosen cap screw and reposition idler roller/bracket until chain deflects **11 mm (7/16 in.)** at mid span opposite idler.
9. Tighten cap screw.
10. Install cover and transport wheels (if equipped).
11. Repeat procedure for opposite side.



REPAIR

CLUTCH CONTROL CABLE

Removal/Installation

1. Remove handlebar cover. (See HANDLEBAR COVER—Removal/Installation on page 6-5.)

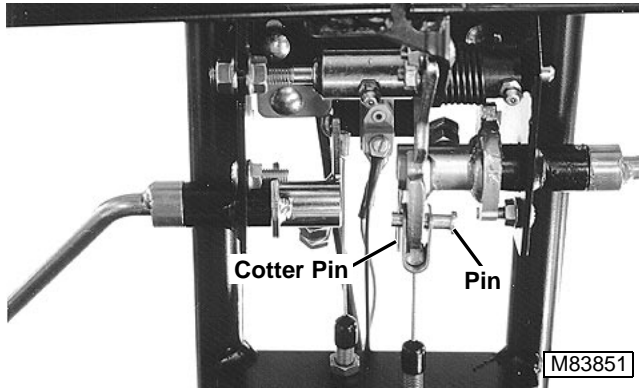

2. Remove cotter pin and pin.

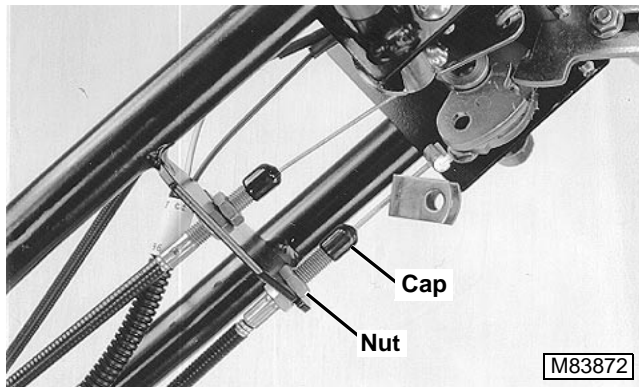

3. Slide cap off cable housing.
4. Remove top nut.
5. Pull cable back until cable housing clears slot.

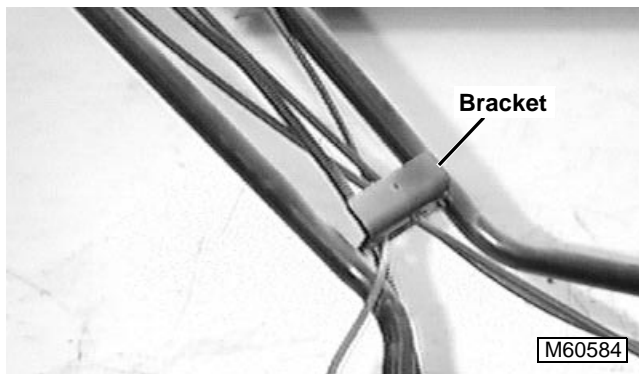

6. Route cable through slotted hole in lower handlebar bracket.

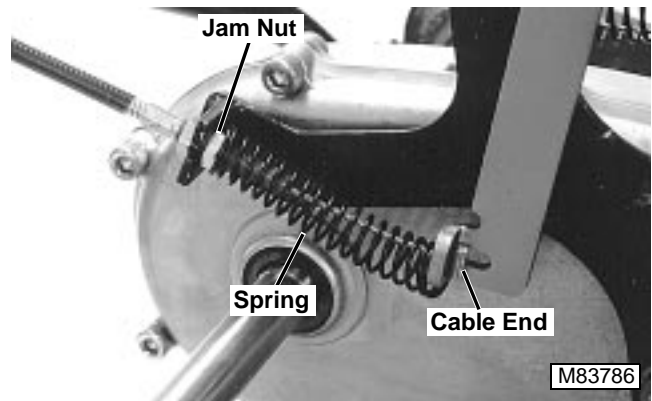

7. Compress spring, disconnect clutch cable end from bracket.
8. Remove spring.
9. Remove jam nut and slide cable end from bracket.

Installation is done in the reverse order of removal.

- Adjust drive belt tension. (See DRIVE BELT TENSION CHECK AND ADJUSTMENT on page 5-10.)

DRIVE BELT REPLACEMENT

1. Remove engine and belts. (See ENGINE—Removal/Installation on page 3-29.)

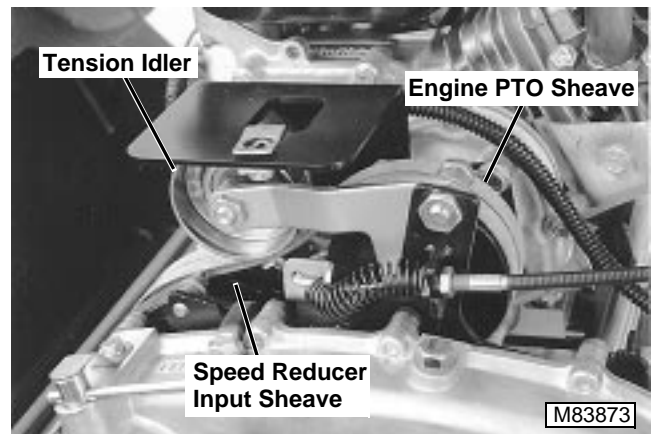

2. Install new belts on gear case sheaves.

NOTE: Belts must be routed UNDER tension idler.

3. Install engine on support and install belts on engine PTO sheaves. DO NOT tighten engine mounting bolts at this time.

IMPORTANT: Engine PTO sheaves MUST align with gear case sheaves.

4. Move engine rearward to tighten belts.

5. Tighten engine mounting bolts.
6. Align belt guide. (See DRIVE BELT GUIDE ADJUSTMENT on page 5-11.)
7. Adjust throttle cable. (See THROTTLE CABLE CHECK AND ADJUSTMENT on page 3-22.)

SPEED REDUCER ASSEMBLY

Removal/Installation

1. Remove transport wheels and drive collars (if equipped). (See TRANSPORT WHEELS on page 9-3.)
2. Remove engine and belts. (See ENGINE—Removal/Installation on page 3-29.)
3. Remove clutch cable. (See CLUTCH CONTROL CABLE—Removal/Installation on page 5-14.)
4. Remove park brake cable. (See PARK BRAKE CABLE REPLACEMENT on page 7-8.)

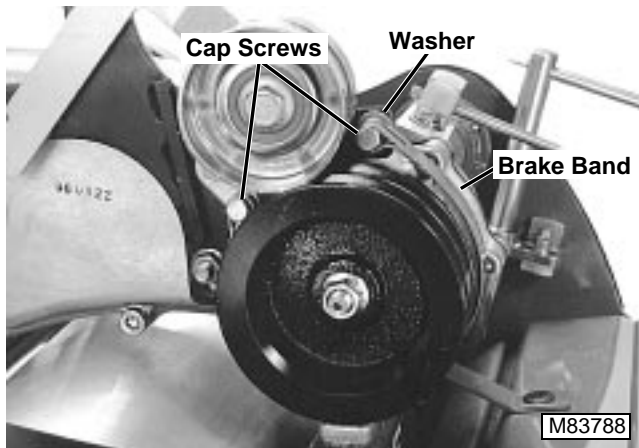

5. Remove cap screws, washer and nuts.
6. Remove brake band.

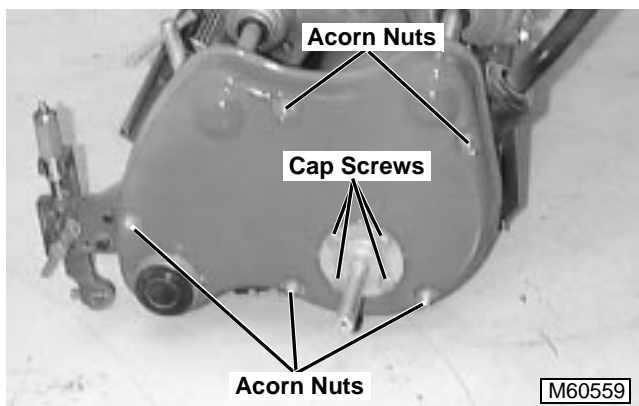

7. Loosen four bearing housing cap screws.
8. Remove five acorn nuts, washers and shoulder bolts, and remove left drive cover.

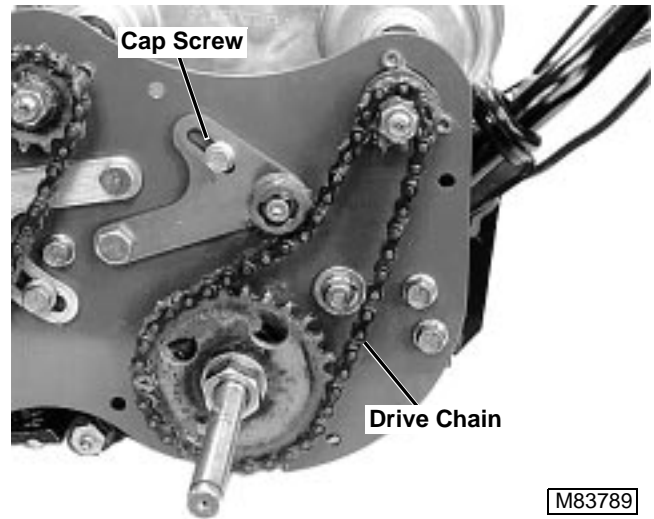

9. Loosen cap screw to release chain tension.
10. Disconnect master link and remove transport roller drive chain.

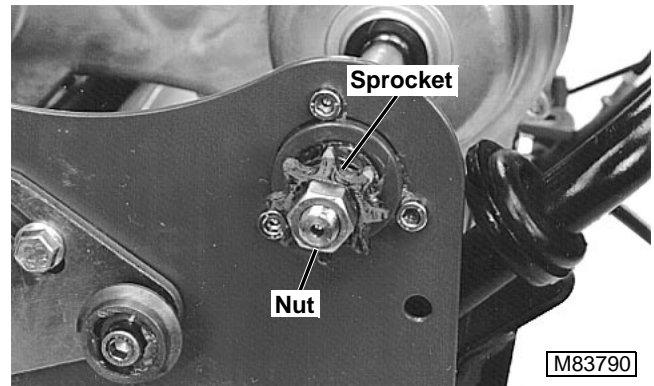

11. Remove nut.
12. Remove sprocket and key.

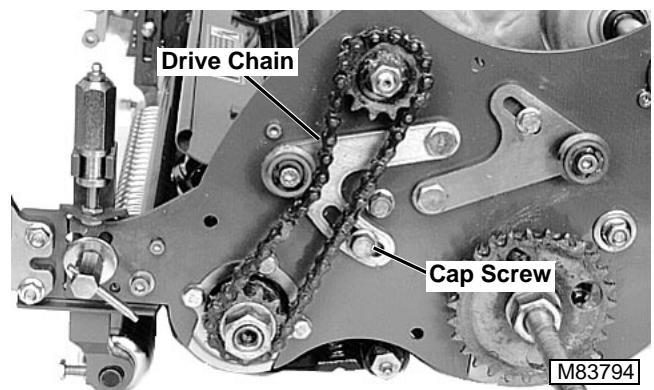

13. Loosen cap screw to release chain tension.
14. Disconnect master link and remove reel drive chain.

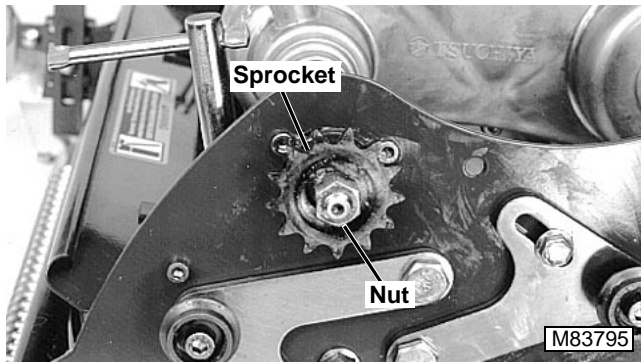

- 15. Remove nut.
- 16. Remove sprocket and key.

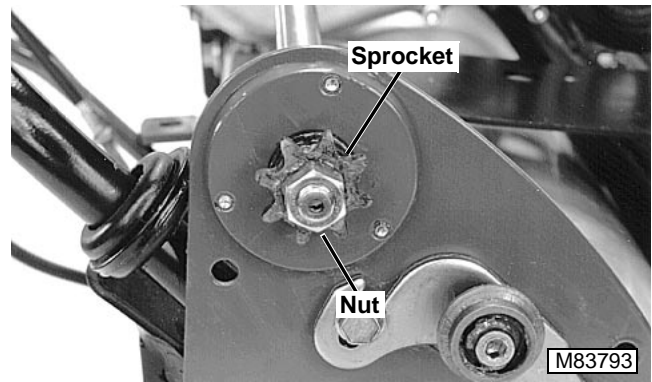

- 21. Remove nut.
- 22. Remove sprocket and key.

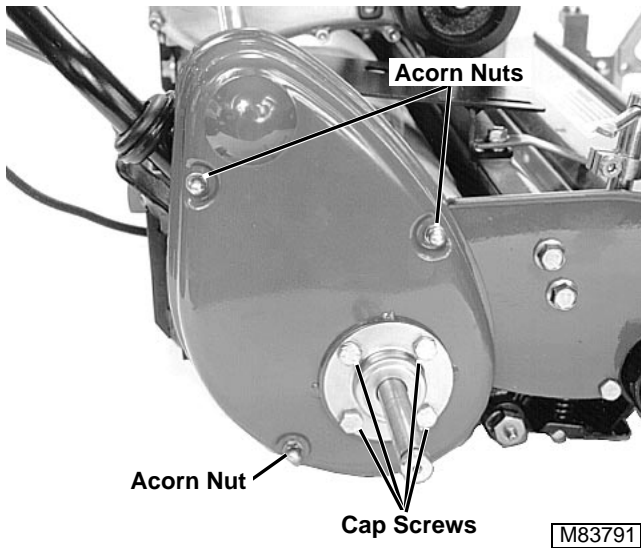

- 17. Loosen four bearing housing cap screws.
- 18. Remove three acorn nuts, washers and shoulder bolts, and remove right drive cover.

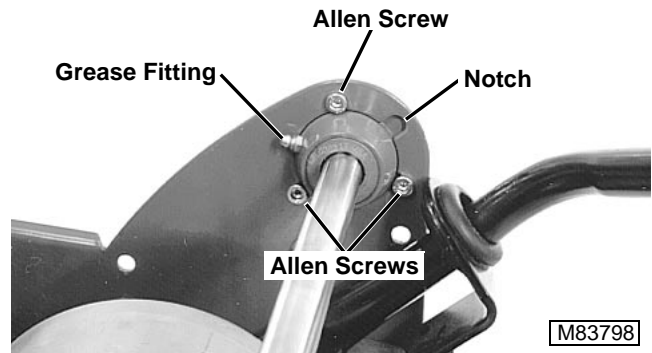

- 23. Remove three allen screws.
- 24. Rotate bearing housing until grease fitting aligns with notch in frame. Remove right bearing housing assembly.

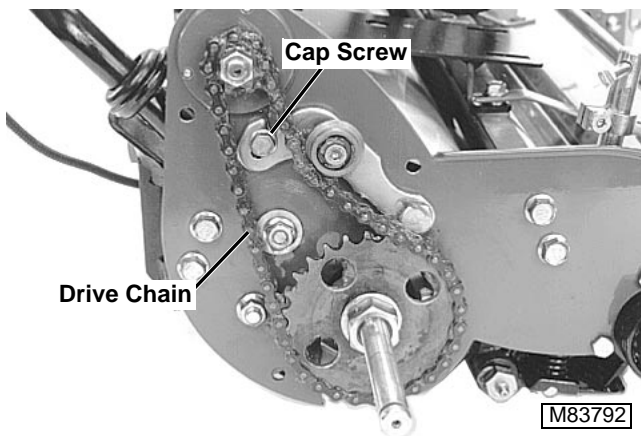

- 19. Loosen cap screw to release chain tension.
- 20. Disconnect master link and remove transport roller drive chain.

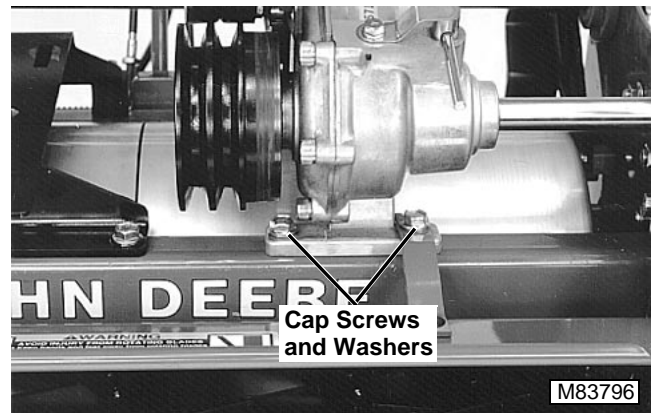

- 25. Remove front speed reducer mounting cap screws and washers.



26. Remove rear speed reducer cap screws and washers.
27. Slide speed reducer assembly to the right and remove.

Installation is done in the reverse order of removal.

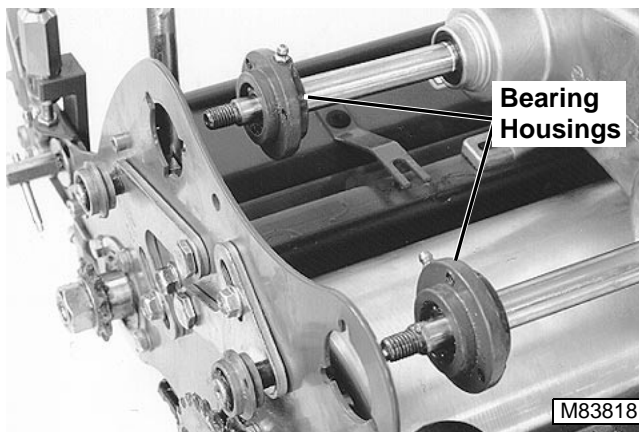

IMPORTANT: To aid in installation and prevent damage to bearings and seals, remove left side bearing housing assemblies and install onto shafts before sliding speed reducer assembly into place.

- Fill speed reducer assembly with oil meeting specifications. (See SPEED REDUCER OIL—NORTH AMERICA or SPEED REDUCER OIL—EUROPE on page 2-10.)
- Adjust drive chain tension. (See TRANSPORT ROLLER DRIVE CHAIN TENSION ADJUSTMENT on page 5-13.)
- Adjust drive belt tension. (See DRIVE BELT TENSION CHECK AND ADJUSTMENT on page 5-10.)
- Align belt guide. (See drive DRIVE BELT GUIDE ADJUSTMENT on page 5-11.)
- Adjust throttle cable. (See THROTTLE CABLE CHECK AND ADJUSTMENT on page 3-22.)
- Adjust park brake. (See PARK BRAKE CHECK AND ADJUSTMENT on page 7-7.)

Disassembly/Inspection

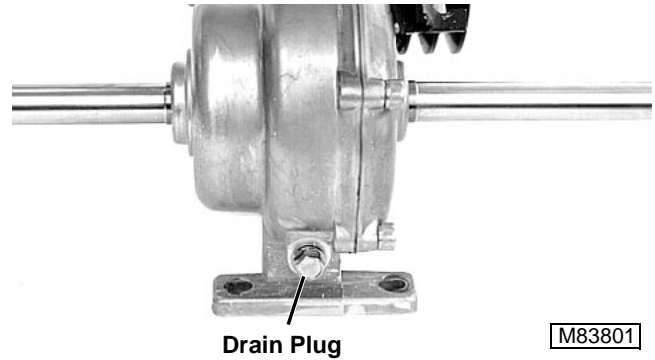

NOTE: Speed reducer oil capacity is approximately 0.5 L (0.5 qt).

1. Remove drain plug and drain oil into properly marked container.

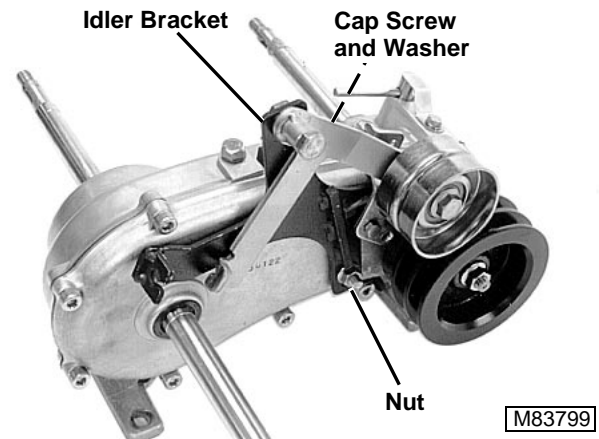

2. Remove nut and washer, cap screw and idler bracket.

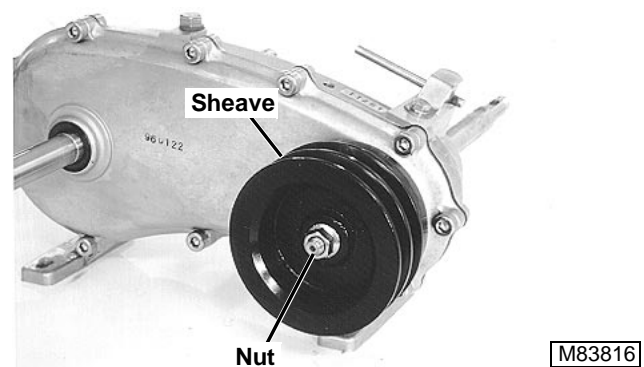

3. Remove nut, sheave and key.

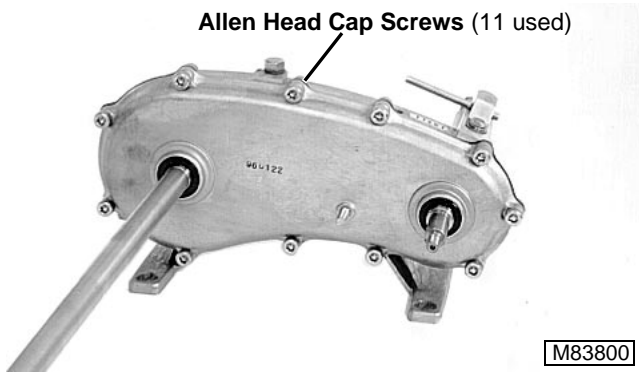

4. Remove 11 allen head cap screws.
5. Remove cover.

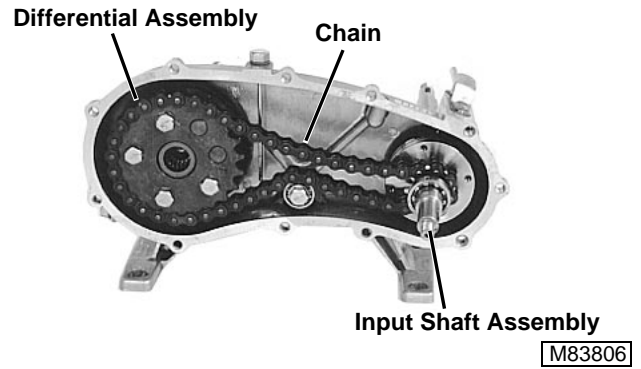

9. Remove differential assembly, chain and input shaft assembly as a unit.

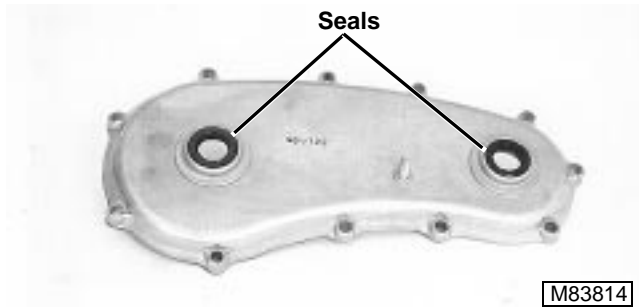

6. Remove seals.

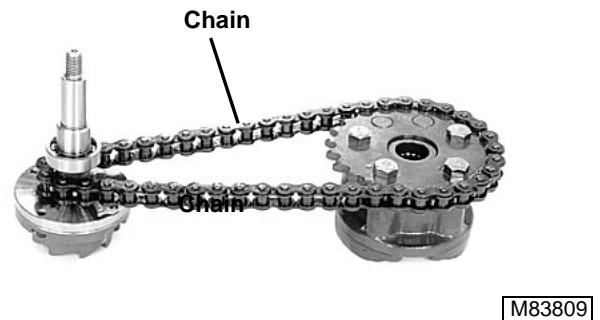

10. Remove chain.
11. Inspect chain for worn or loose links.

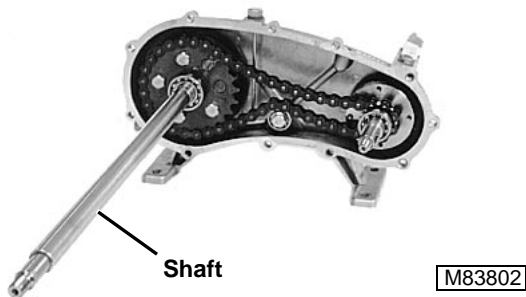

7. Remove shaft.

Input Shaft Assembly:

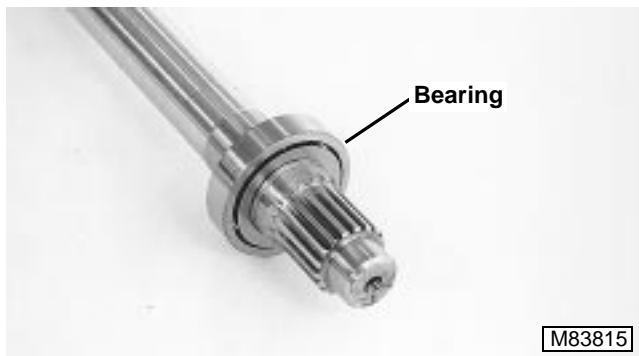

8. Inspect bearing. Replace bearing if worn or damaged.

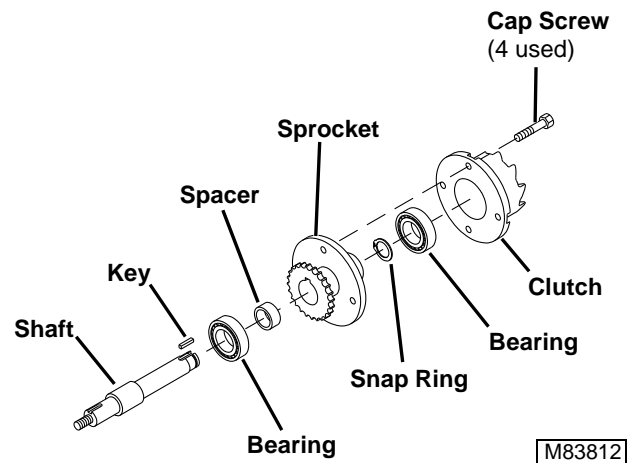

12. Remove four cap screws.
13. Remove clutch and bearing.
14. Remove snap ring.
15. Remove chain sprocket, spacer, bearing and key from shaft.

Differential Assembly:

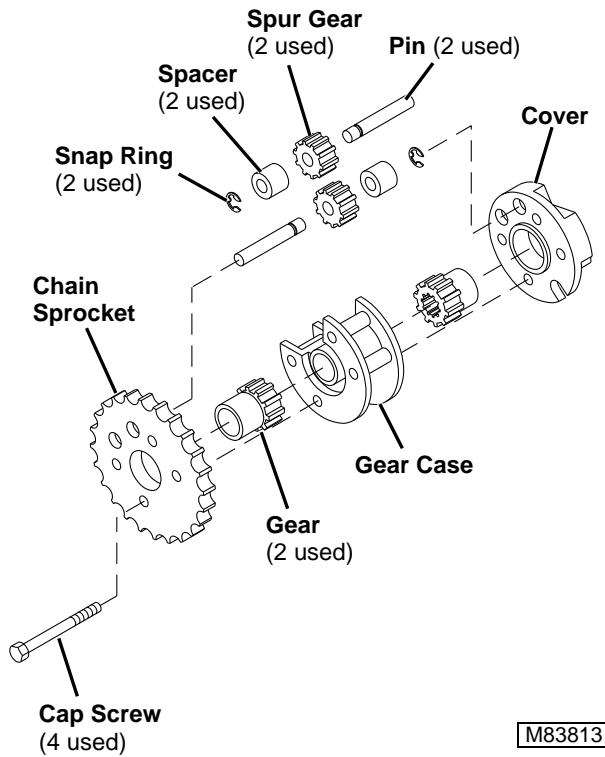

- 16. Remove four cap screws.
- 17. Remove chain sprocket and cover from gear case.
- 18. Remove gears from gear case.
- 19. Remove snap ring and remove spur gears and spacers from pins.

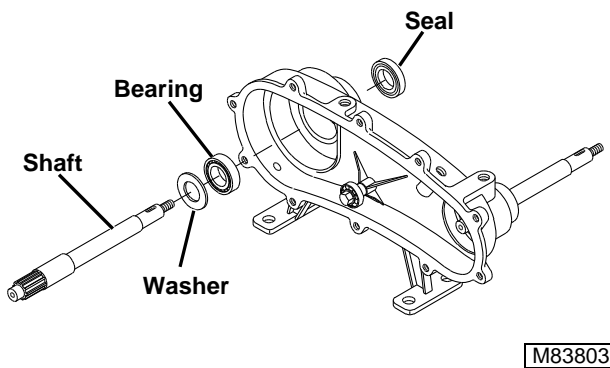

- 20. Remove shaft, washer, bearing and seal.

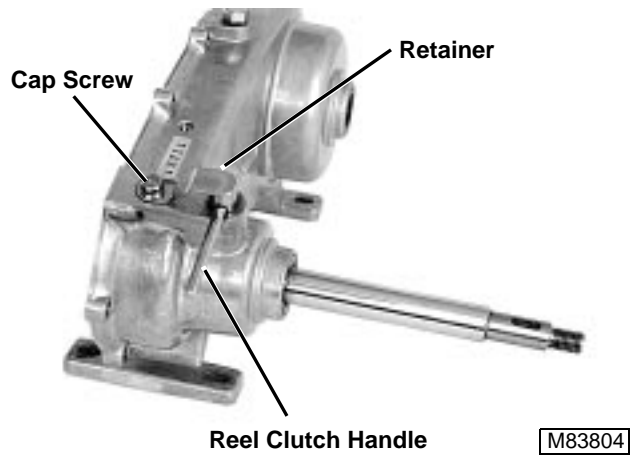

- 21. Remove cap screw, washer, retainer and reel clutch handle.



- 22. Inspect O-ring and eccentric on reel clutch handle.

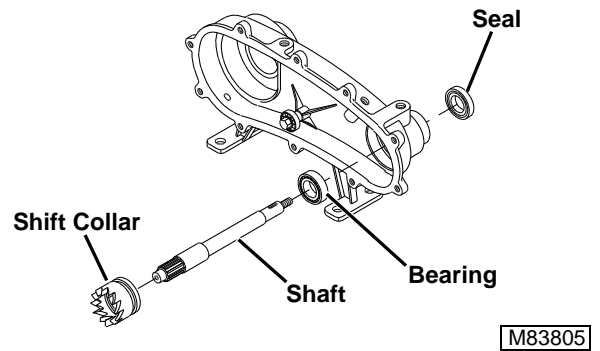

- 23. Remove shaft, shift collar, bearing and seal.

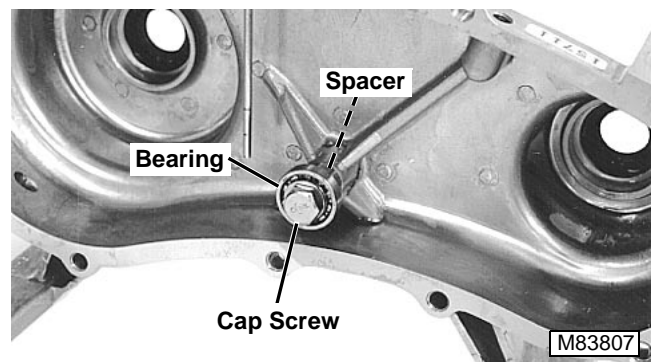

- 24. Remove cap screw, bearing and spacer. Inspect bearing and replace if necessary.
- 25. Remove gasket material from mating surfaces.

CAUTION

Reduce compressed air to less than 210 kPa (2 bar) (30 psi) when using for cleaning purposes. Clear area of bystanders, guard against flying chips, and wear personal protection equipment including eye protection.

26. Clean all metal parts with solvent and blow dry with compressed air.
27. Inspect all parts for damage, nicks or unusual wear. Replace parts as necessary.

Assembly

IMPORTANT: Always use new seal and O-rings. Damaged or used parts will leak.

NOTE: Lubricate all seals and O-rings with multi-purpose grease during installation.

Apply clean oil to all internal parts during assembly. (See SPEED REDUCER OIL—NORTH AMERICA or SPEED REDUCER OIL—EUROPE on page 2-10.)

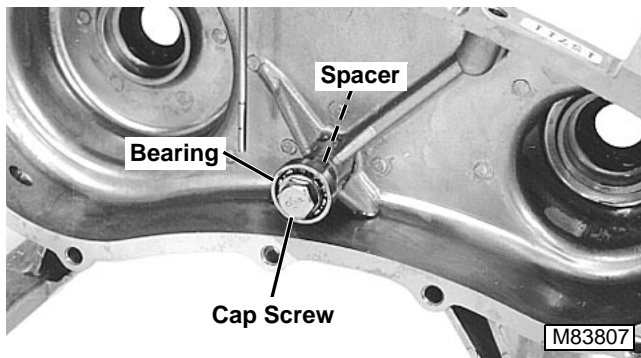

1. Install idler bearing, spacer and cap screw.

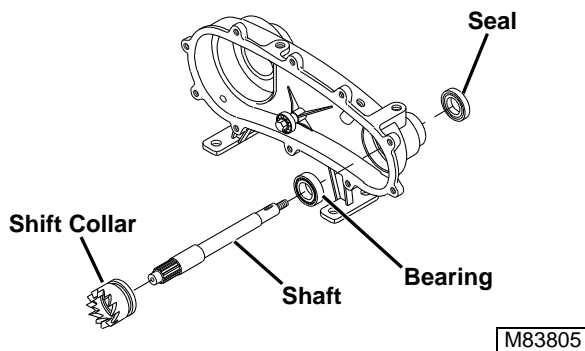

2. Install new seal

NOTE: Make sure bearing is full seated in housing.

3. Install bearing in housing.
4. Install shaft and shift collar.

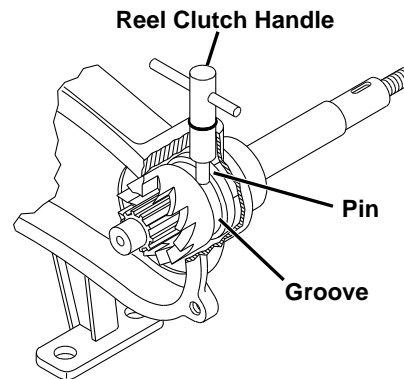

NOTE: Align pin on reel clutch handle with groove in shift collar.

5. Install reel clutch handle.

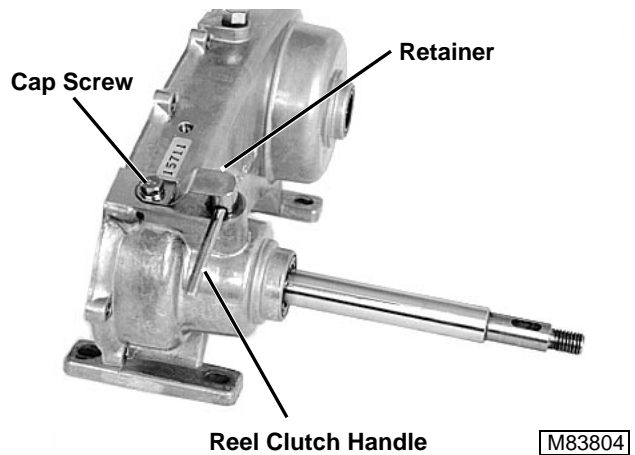

6. Install cap screw, washer and retainer.

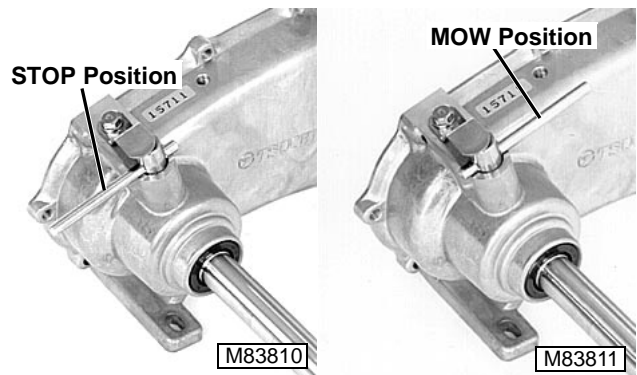

7. Check for full movement of reel clutch handle from STOP to MOW position.

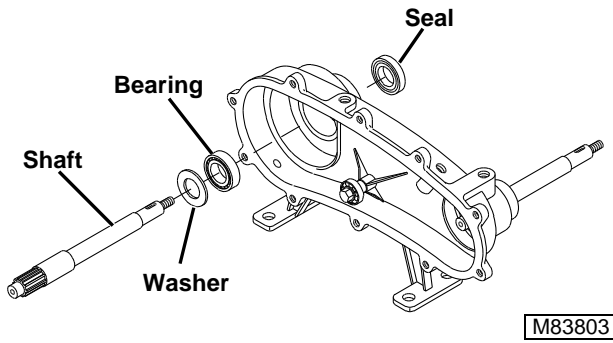

8. Install new seal.

NOTE: Make sure bearing is full seated in housing.

- 9. Install bearing in housing.
- 10. Install shaft and washer.

Differential Assembly:

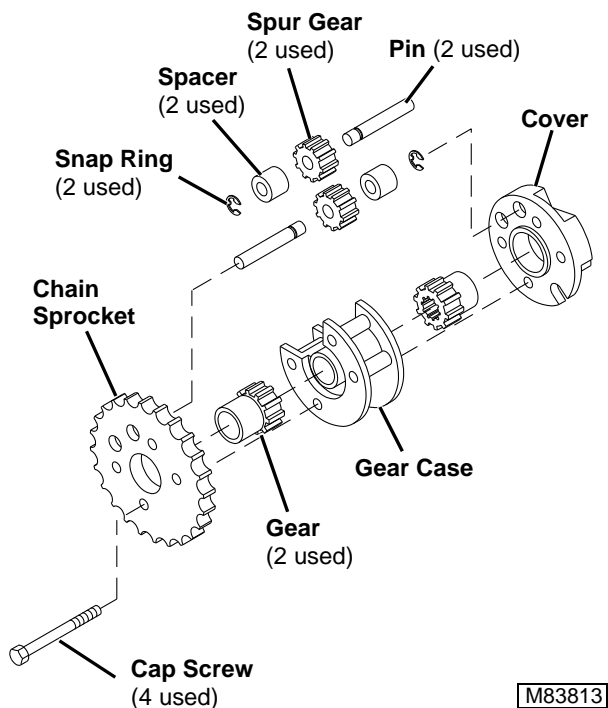

- 11. Install gears in gear case with gear teeth facing inside of gear case.
- 12. Install spur gears and spacers on pins. Secure with snap ring.

NOTE: Install spur gear shaft assemblies with one spur gear against chain sprocket and other spur gear against cover.

- 13. Assemble spur gear assemblies, gear case, cover and chain sprocket, using four cap screws.

Input Shaft Assembly:

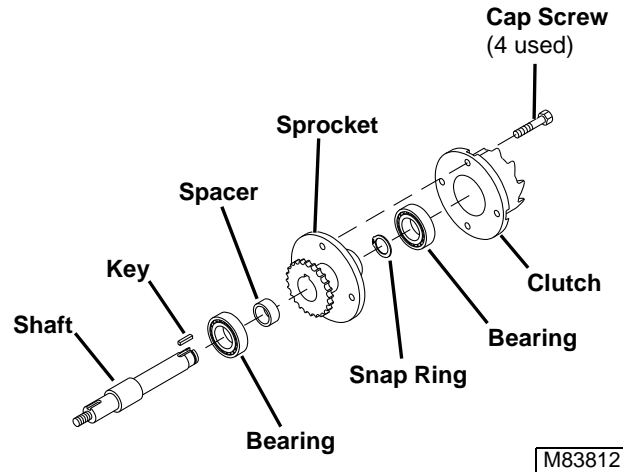

- 14. Install bearing, spacer, key and sprocket on shaft. Secure with snap ring.
- 15. Install bearing in clutch.
- 16. Install clutch on sprocket using four cap screws.

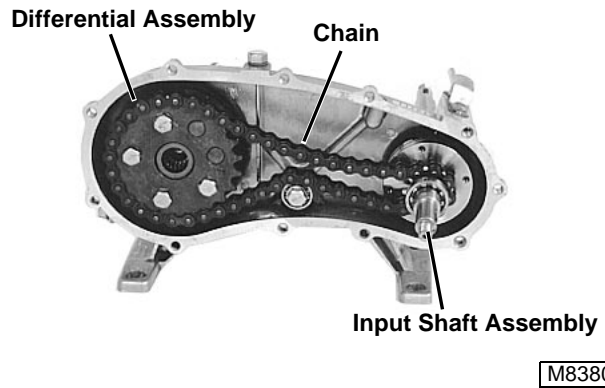

- 17. Install chain around differential assembly and input shaft assembly and install as a unit.

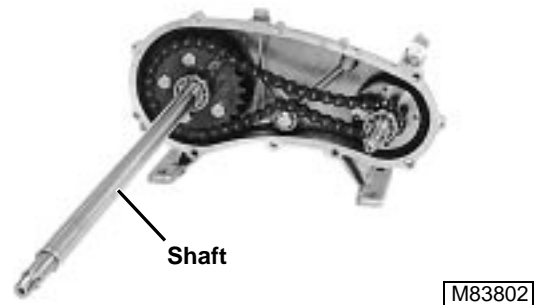

- 18. Install shaft in differential assembly.

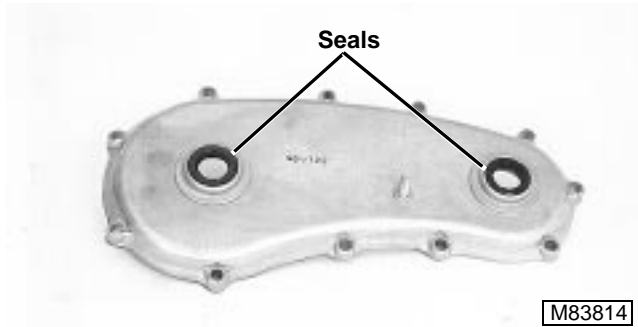

19. Install new seals in cover.



IMPORTANT: Apply multipurpose grease to lips of seals and wrap ends of shafts with tape to prevent damage to seal when installing cover.

20. Install cover with new gasket.
21. Install cap screws.

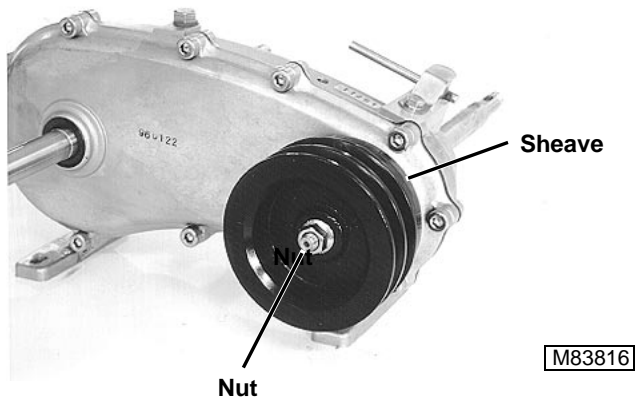

22. Install key, sheave and nut.

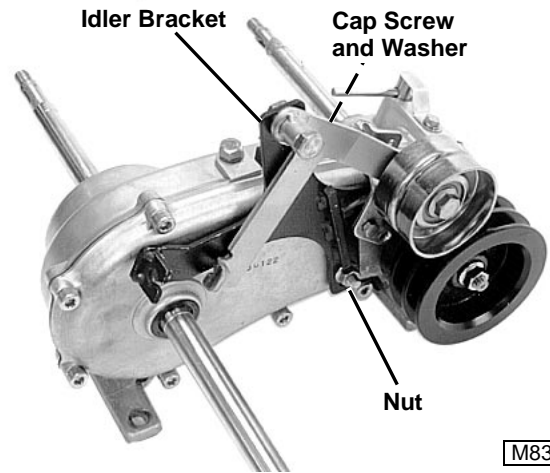

23. Install idler bracket, nut and cap screw and washer.
24. Fill speed reducer to proper level with oil meeting specifications. (See SPEED REDUCER OIL—NORTH AMERICA or SPEED REDUCER OIL—EUROPE on page 2-10.)

TRACTION ROLLER ASSEMBLY

Removal/Installation

1. Remove transport wheels and drive collars (if equipped). (See TRANSPORT WHEELS on page 9-3.)

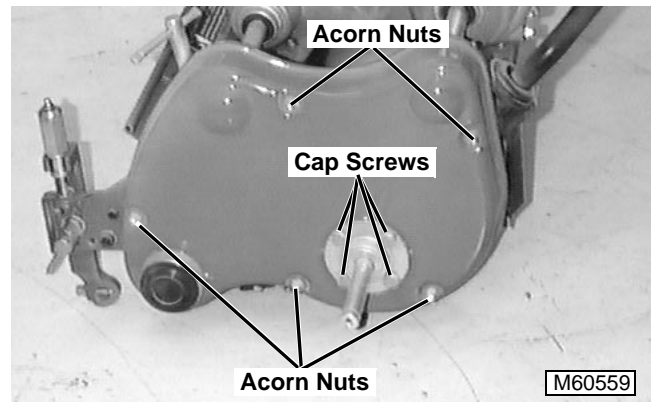

2. Loosen four bearing housing cap screws.
3. Remove five acorn nuts, washers and shoulder bolts, and remove left drive cover.

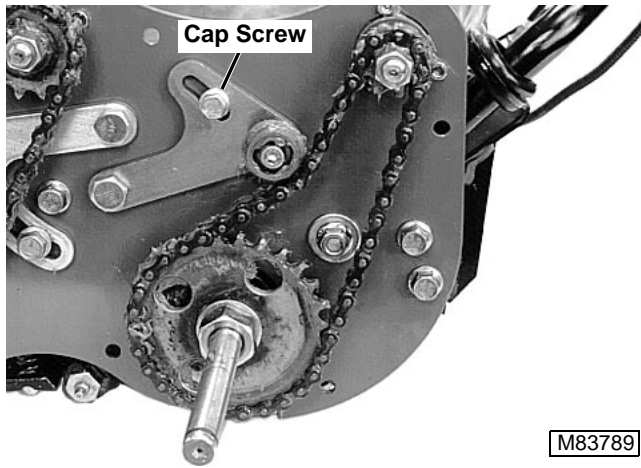

4. Loosen cap screw to release chain tension.
5. Disconnect master link and remove transport roller drive chain.

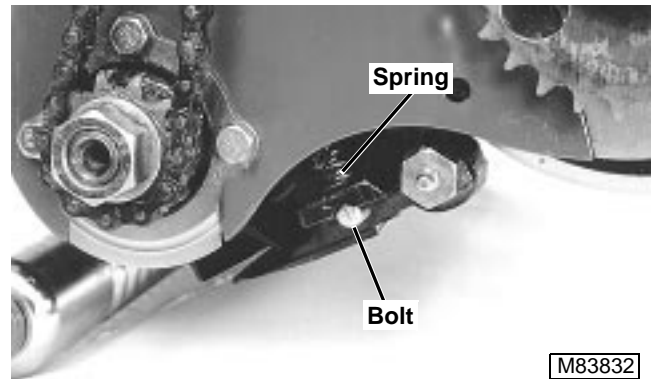
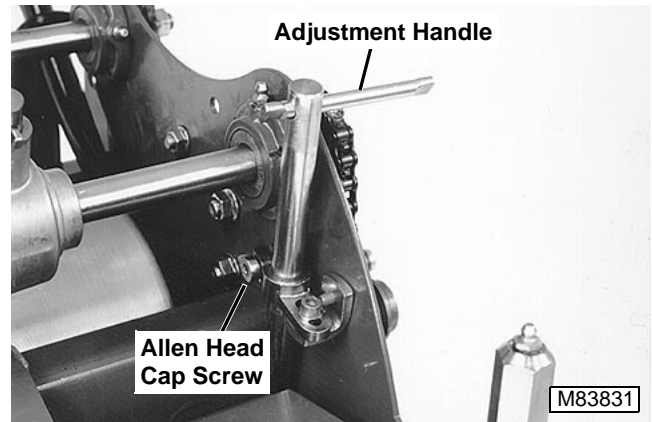

10. Loosen allen head cap screw on both sides of mower.
11. Remove adjustment handles, bolts and springs from both sides of mower.

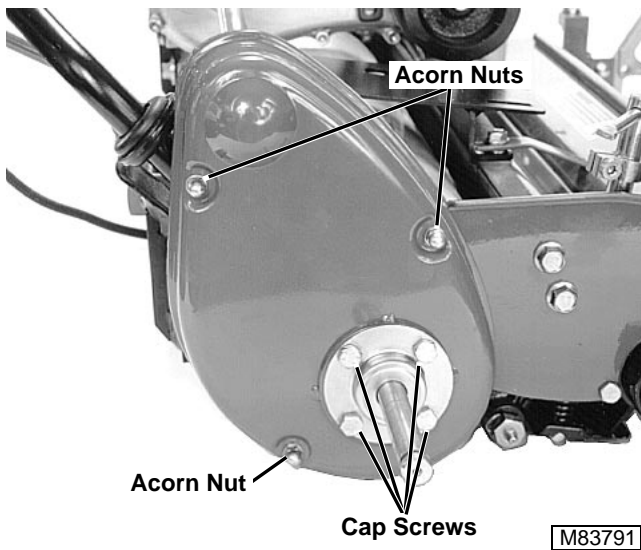

6. Loosen four bearing housing cap screws.
7. Remove three acorn nuts, washers and shoulder bolts, and remove right drive cover.

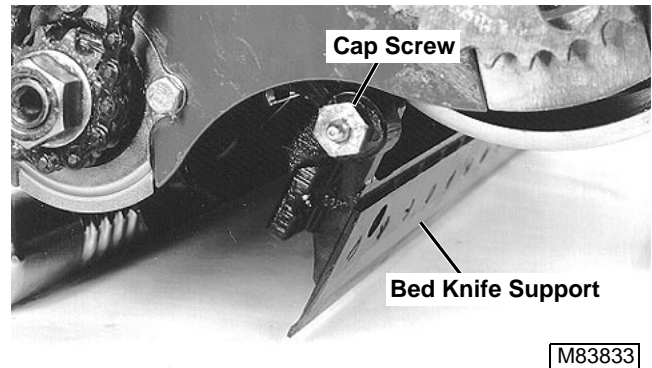

12. Remove cap screws from both sides of mower.
13. Remove bed knife support.

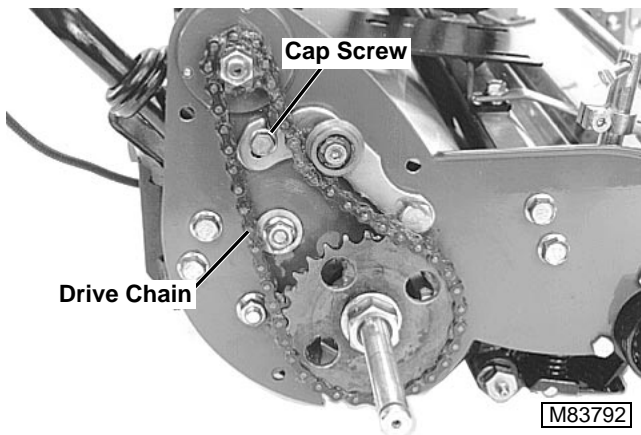

8. Loosen cap screw to release chain tension.
9. Disconnect master link and remove transport roller drive chain.

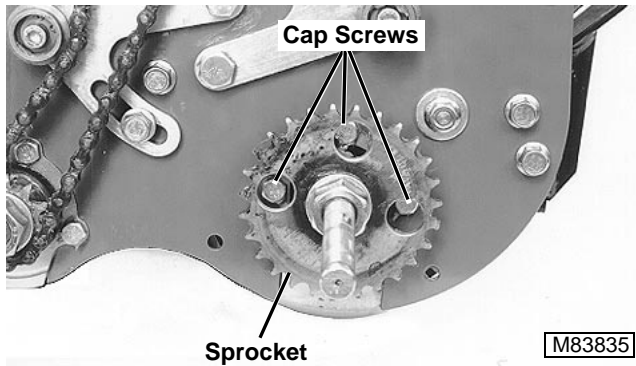

14. **Left Side:** Rotate roller until holes in sprocket align with bearing holder cap screws. Remove three cap screws.

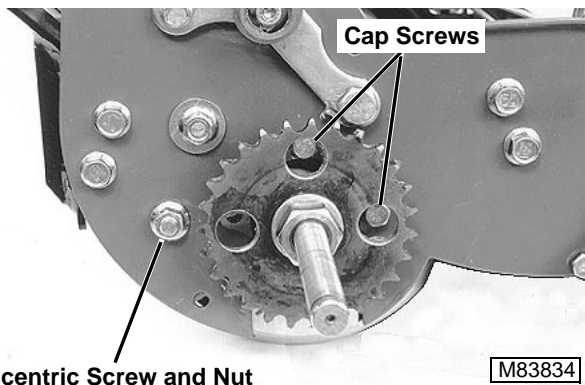

15. **Right Side:** Rotate roller until holes in sprocket align with bearing holder cap screws. Remove two cap screws.
16. Remove bearing holder eccentric screw and nut.
17. Lift mower and remove traction roller assembly.

Installation is done in the reverse order of removal.

- Adjust bed knife-to-reel clearance. (See BED KNIFE-TO-REEL ADJUSTMENT on page 8-15.)
- Adjust traction roller. (See TRACTION ROLLER ADJUSTMENT on page 5-11.)
- Adjust drive chain tension. (See TRANSPORT ROLLER DRIVE CHAIN TENSION ADJUSTMENT on page 5-13.)
- Backlap reel. (See BACKLAPPING PROCEDURE on page 8-16.)

Disassembly/Assembly

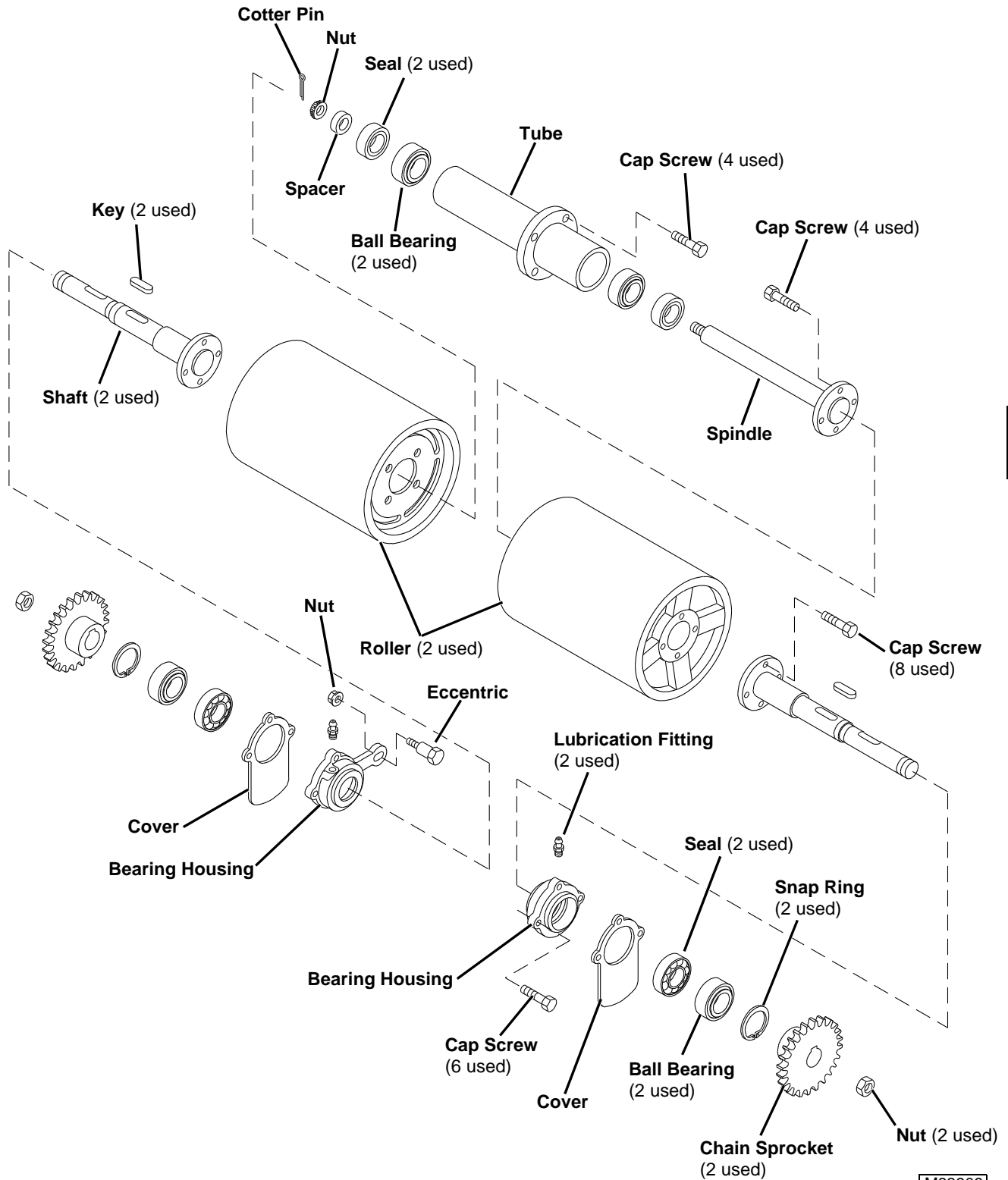

- Inspect all parts for wear or damage. Replace parts as necessary.

- Apply Non-Clay High Temperature EP Grease (North America) or Grease-Gard (Europe) to lubrication fittings and pack inside of tube.

DRIVE CHAIN TENSIONERS

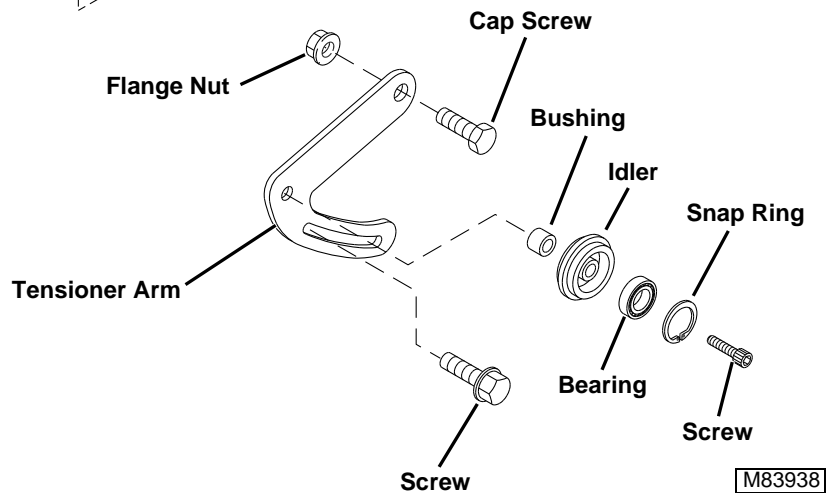
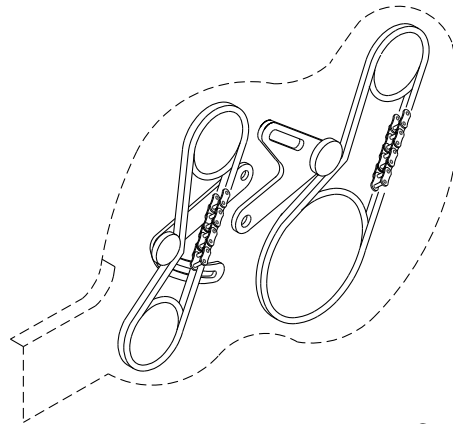
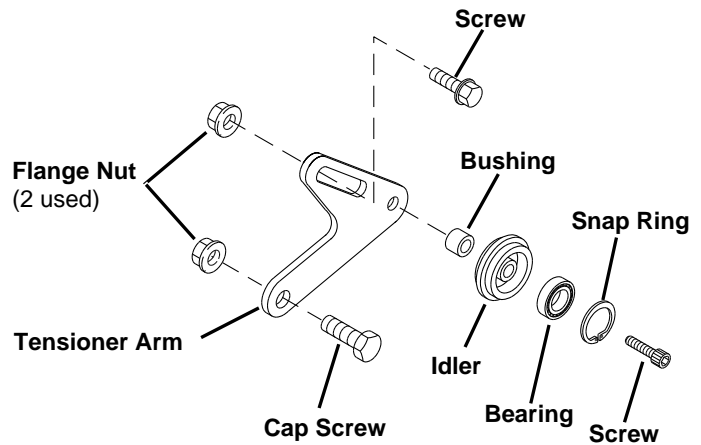
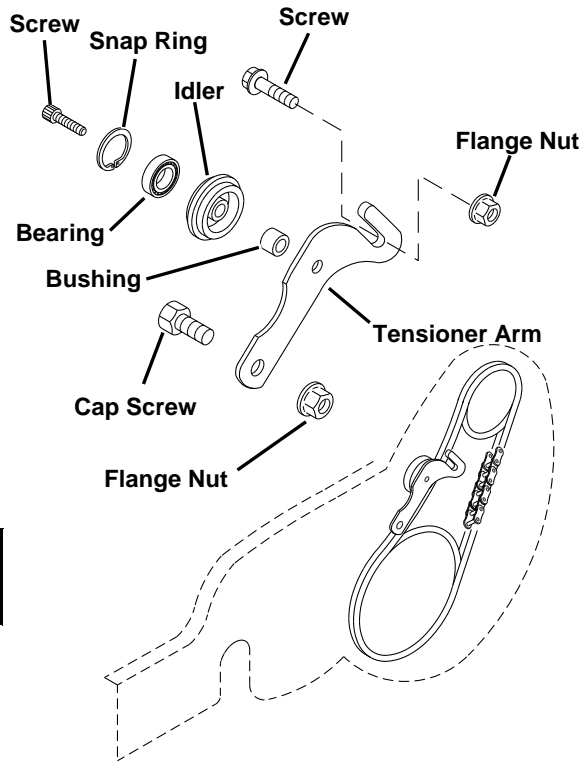

M83938

- Inspect all parts for wear or damage. Replace parts as necessary.
- Adjust tension arms to remove slack in chains. (See TRANSPORT ROLLER DRIVE CHAIN TENSION ADJUSTMENT on page 5-13 and REEL DRIVE CHAIN TENSION ADJUSTMENT on page 8-17.)

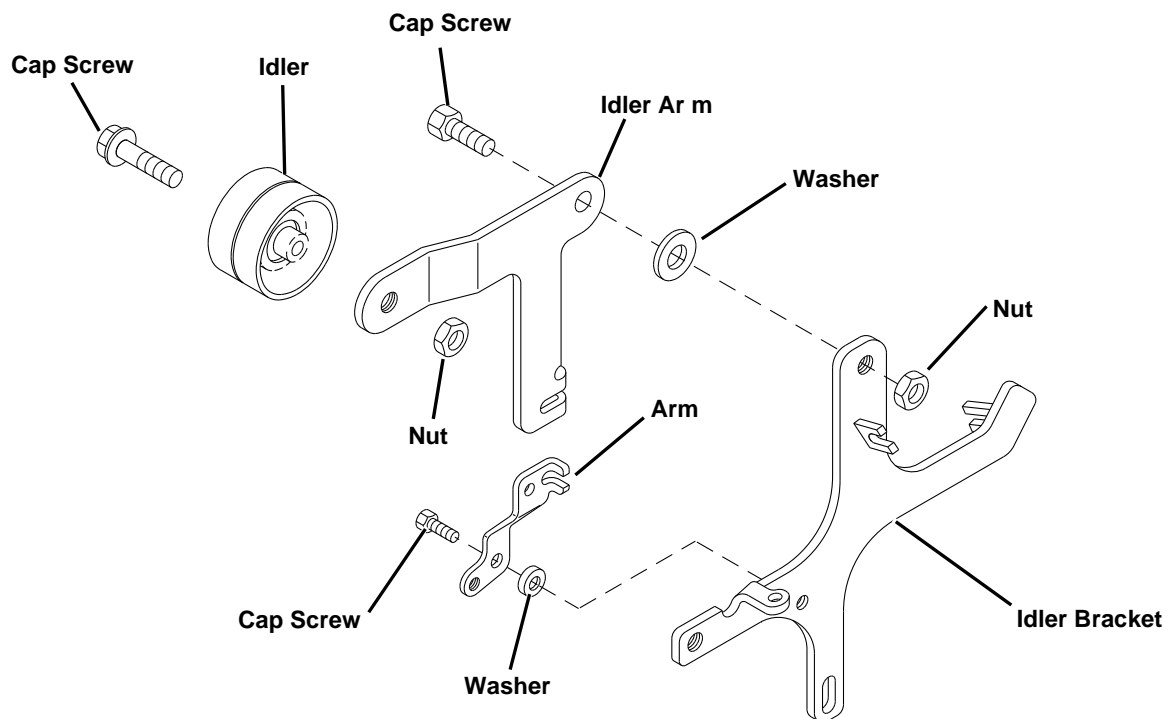
DRIVE BELT IDLER BRACKET ASSEMBLY

M83937

- Inspect all parts for wear or damage. Replace parts as necessary.

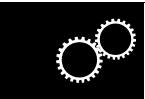

This page intentionally left blank.

CONTENTS

Page

HANDLEBAR AND CONTROLS

COMPONENT LOCATION AND OPERATION

COMPONENT LOCATION 6-2

ADJUSTMENTS

THROTTLE LEVER TENSION ADJUSTMENT..... 6-3

OPERATOR PRESENCE BAIL ADJUSTMENT 6-3

HANDLEBAR HEIGHT ADJUSTMENT..... 6-4

REPAIR

HANDLEBAR COVER..... 6-5

HANDLEBAR ASSEMBLY..... 6-5

CLUTCH CONTROL/OPERATOR PRESENCE BAIL..... 6-7

BRAKE CONTROL/THROTTLE LEVER..... 6-8



COMPONENT LOCATION AND OPERATION

COMPONENT LOCATION

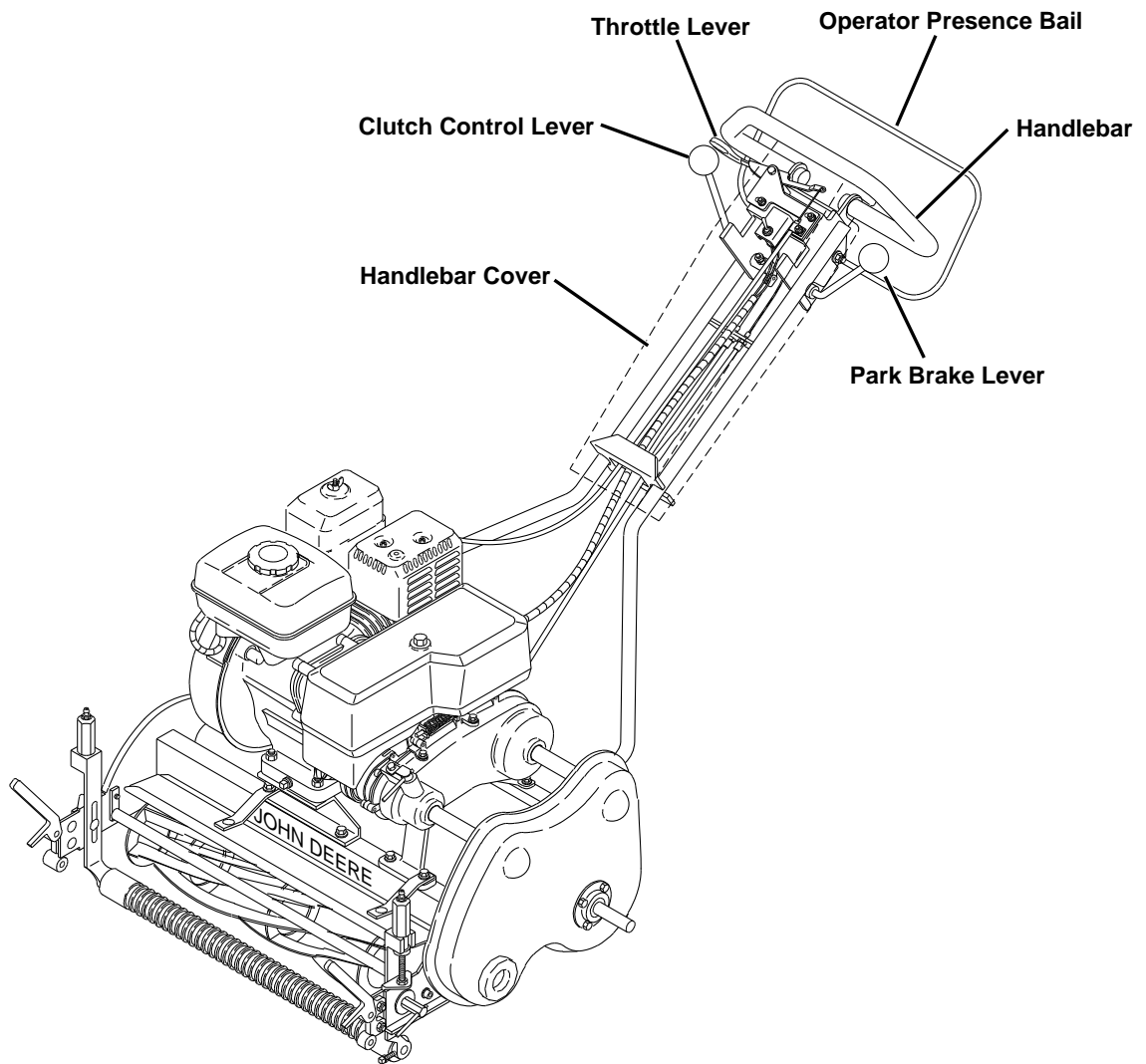

M83933

ADJUSTMENTS

THROTTLE LEVER TENSION ADJUSTMENT

Reason:

To apply enough tension to hold throttle position, yet allow easy throttle movement.

Procedure:

1. Park machine on a level surface.
2. Move RUN/OFF switch to OFF position.
3. Move Travel Clutch Lever to NEUTRAL position.
4. Engage park brake.
5. Remove handlebar cover. (See HANDLEBAR COVER—Removal/Installation on page 6-5.)

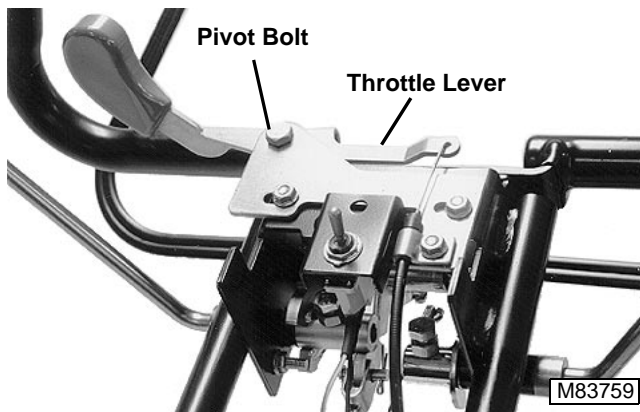

6. Using two wrenches, tighten or loosen the lock on throttle pivot bolt. At proper tension, the throttle should hold desired throttle setting during operation, yet allow easy movement.
7. Install handlebar cover.

OPERATOR PRESENCE BAIL ADJUSTMENT

Reason:

To ensure that all moving parts are disengaged when bail is released.

Procedure:

1. Park machine on a level surface.
2. Move RUN/OFF switch to OFF position.
3. Move Travel Clutch Lever to NEUTRAL position.
4. Engage park brake.

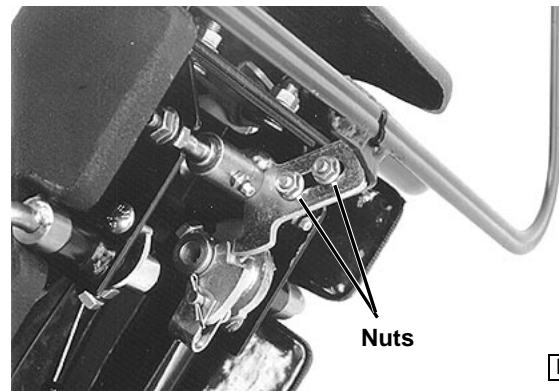

5. Loosen two nuts.

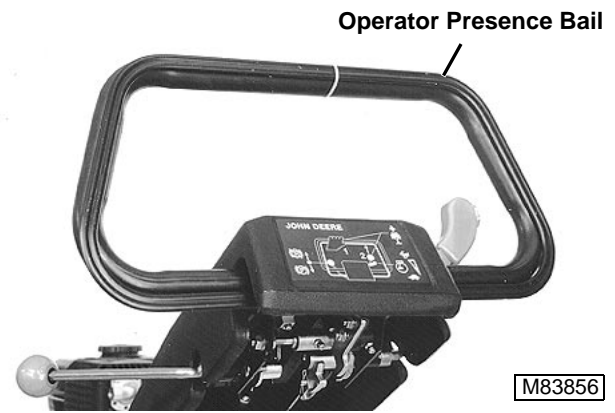

6. Secure bail against handlebar loop.

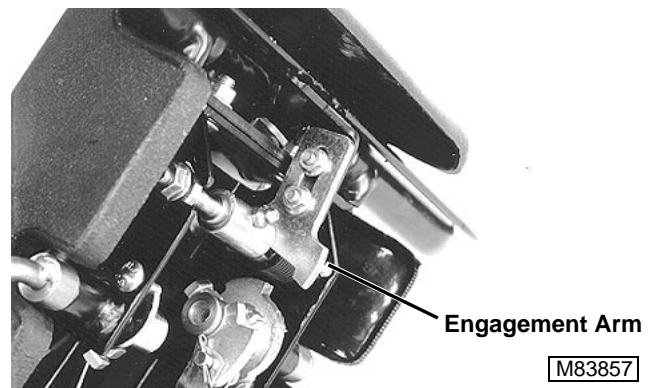

7. Rotate engagement arm upward as far as possible.
8. Tighten nuts
9. Release operator presence bail.

HANDLEBAR HEIGHT ADJUSTMENT

Reason:

To allow the operator to choose a comfortable handlebar height.

Procedure:

1. Park machine on a level surface.
2. Move RUN/OFF switch to OFF position.
3. Move Travel Clutch Lever to NEUTRAL position.
4. Engage park brake.

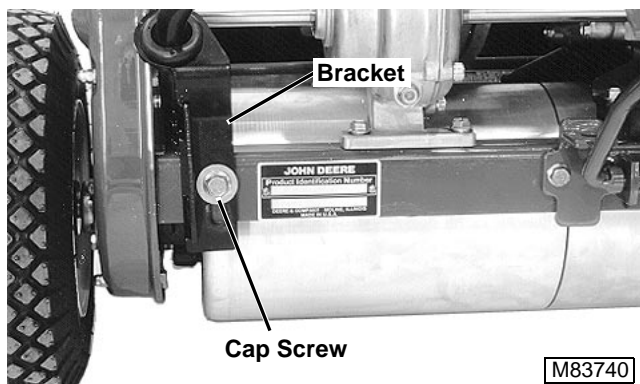

5. Loosen cap screw on each side of mower.

NOTE: Brackets *MUST* be straight up and down.

6. Adjust bracket up or down as desired and tighten cap screws.

REPAIR

HANDLEBAR COVER

Removal/Installation



1. Move throttle lever to FAST idle position.
2. Remove two cap screws and washer.
3. Remove cover.

Installation is done in the reverse order of removal.

HANDLEBAR ASSEMBLY

Removal/Installation

1. Remove handlebar cover. (See HANDLEBAR COVER—Removal/Installation.)

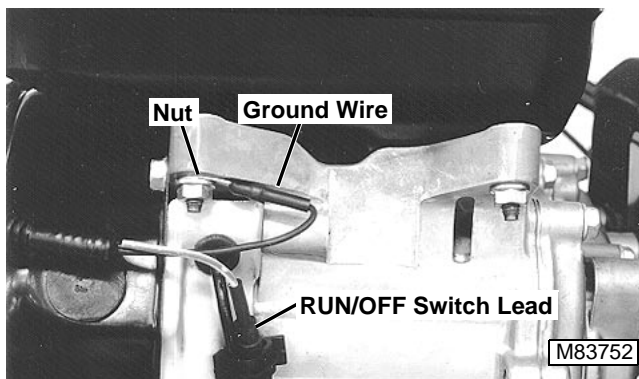

2. Disconnect RUN/OFF harness at engine.
3. Remove nut and ground wire.

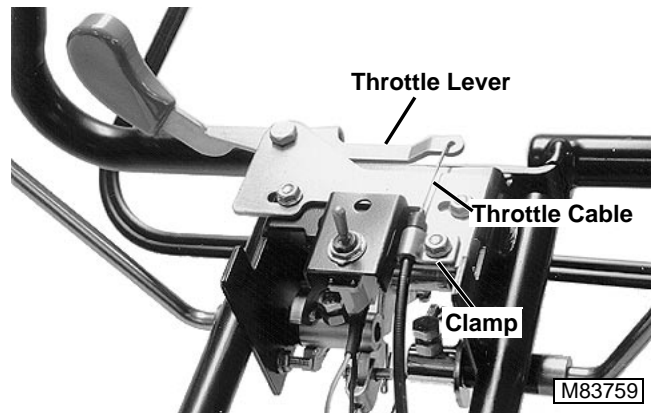

4. Loosen clamp and disconnect throttle cable at throttle lever.

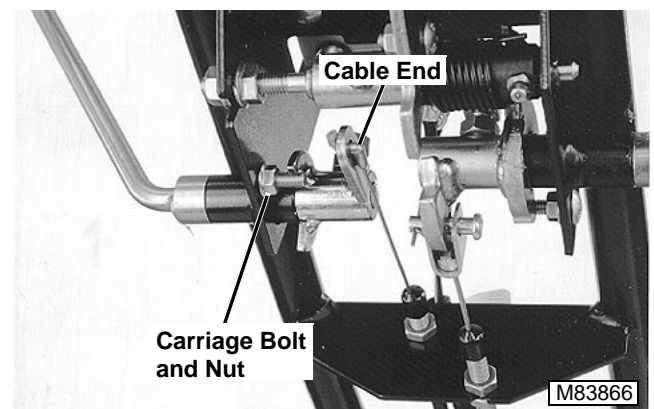

5. Remove nut and carriage bolt
6. Rotate brake lever down.
7. Disconnect cable end from lever.

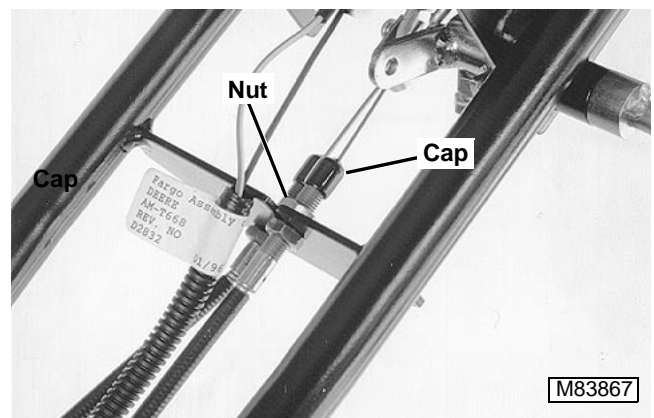

8. Slide cap off cable housing.
9. Remove top nut.
10. Pull cable back until brake cable housing clears slot.

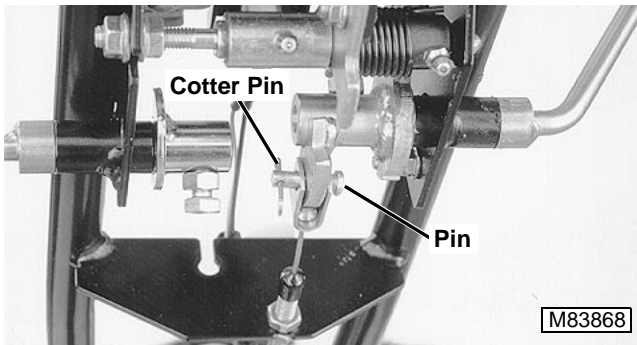

11. Remove cotter pin and pin from clutch control cable.

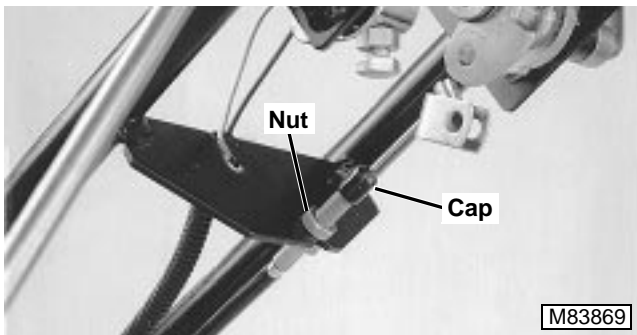

- 12. Slide cap off cable housing.
- 13. Remove top nut.
- 14. Pull cable back until clutch control cable housing clears slot.

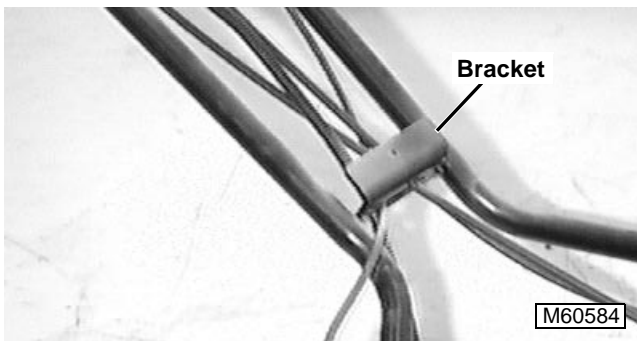

15. Route cables through slotted hole in lower handlebar bracket.

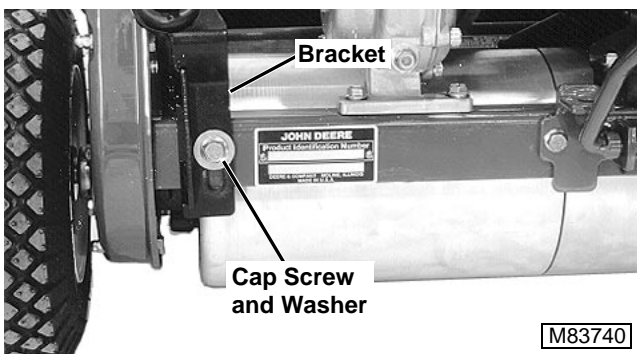

16. Remove cap screw and washer and bracket from each side of mower.

- 17. Slide handlebar free of pegs.
- 18. Remove handlebar assembly.

Installation is done in the reverse order of removal.

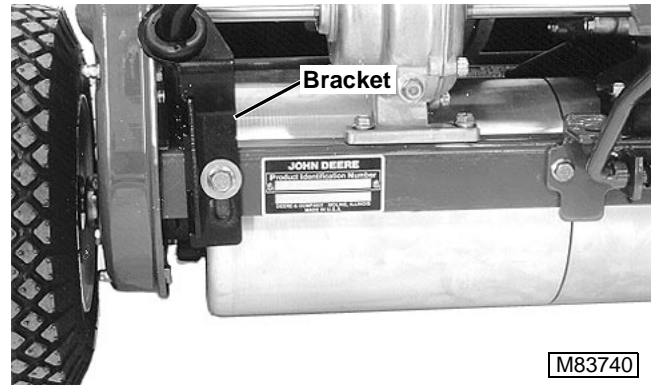

- Adjust handlebar brackets straight up and down before tightening.

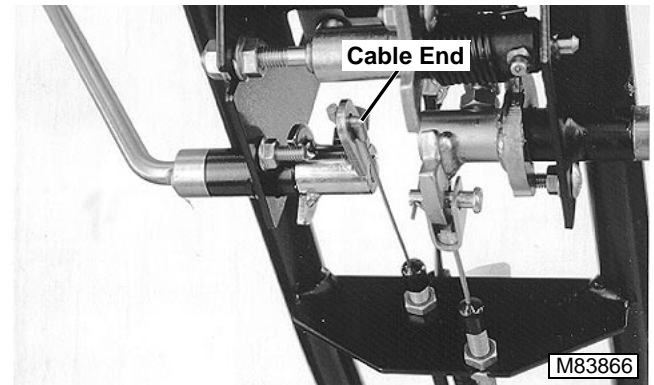

IMPORTANT: Hooked end of brake cable end MUST swing freely.

- Apply Multi-Purpose grease to hooked end of brake cable.
- Adjust park brake. (See PARK BRAKE CHECK AND ADJUSTMENT on page 7-7.)
- Adjust throttle cable. (See THROTTLE CABLE CHECK AND ADJUSTMENT on page 3-22.)
- Adjust clutch control cable. (See DRIVE BELT TENSION CHECK AND ADJUSTMENT on page 5-10.)



CLUTCH CONTROL/ OPERATOR PRESENCE BAIL

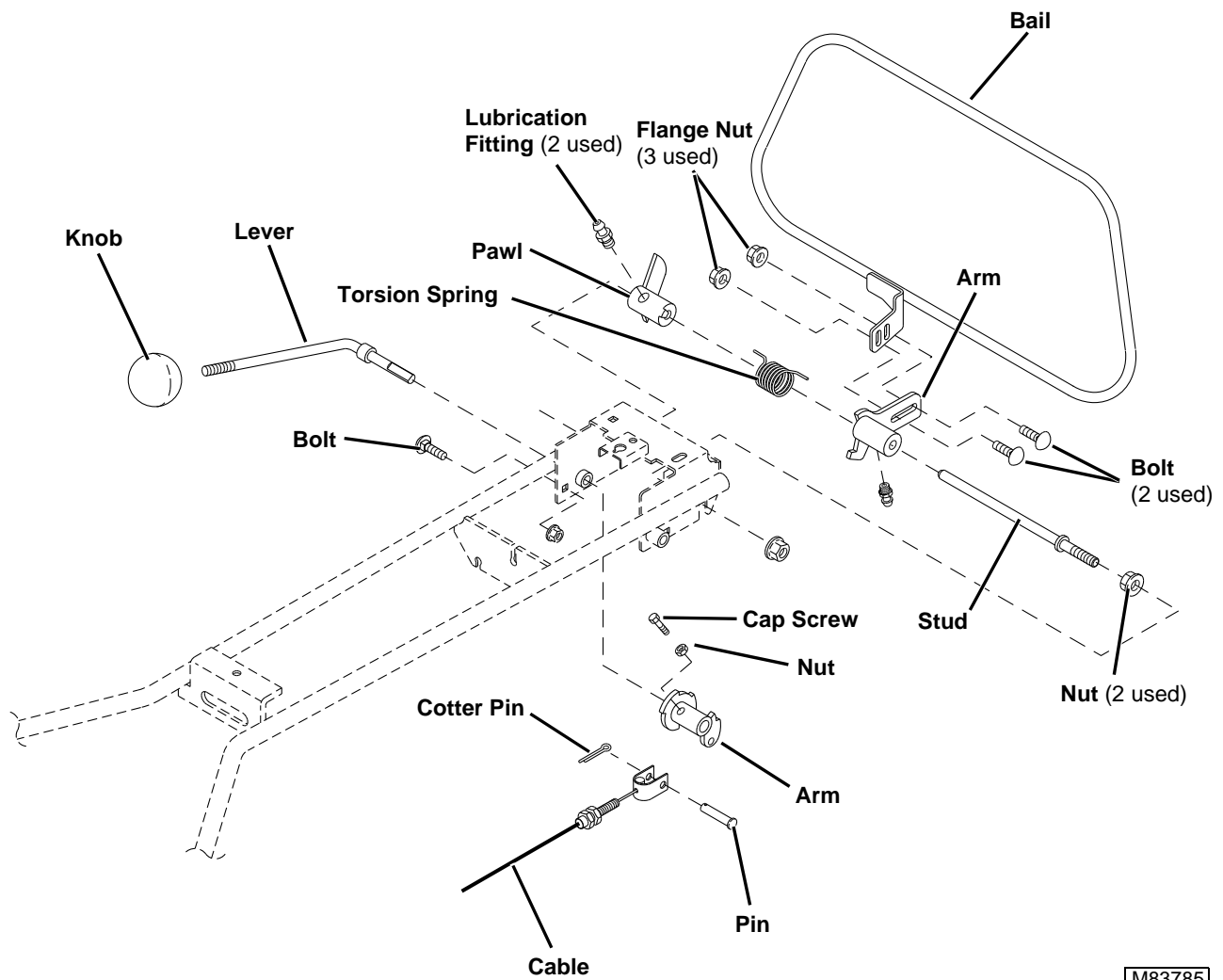

1. Remove handlebar cover. (See HANDLEBAR COVER—Removal/Installation on page 6-5.)
2. Inspect all parts for wear or damage. Replace parts as necessary.

Installation is done in the reverse order of removal.

- Apply Multi-purpose grease to lubrication fittings.
- Adjust clutch control cable. (See DRIVE BELT TENSION CHECK AND ADJUSTMENT on page 5-10.)
- Adjust operator presence bail. (See OPERATOR PRESENCE BAIL ADJUSTMENT on page 6-3.)

BRAKE CONTROL/THROTTLE LEVER

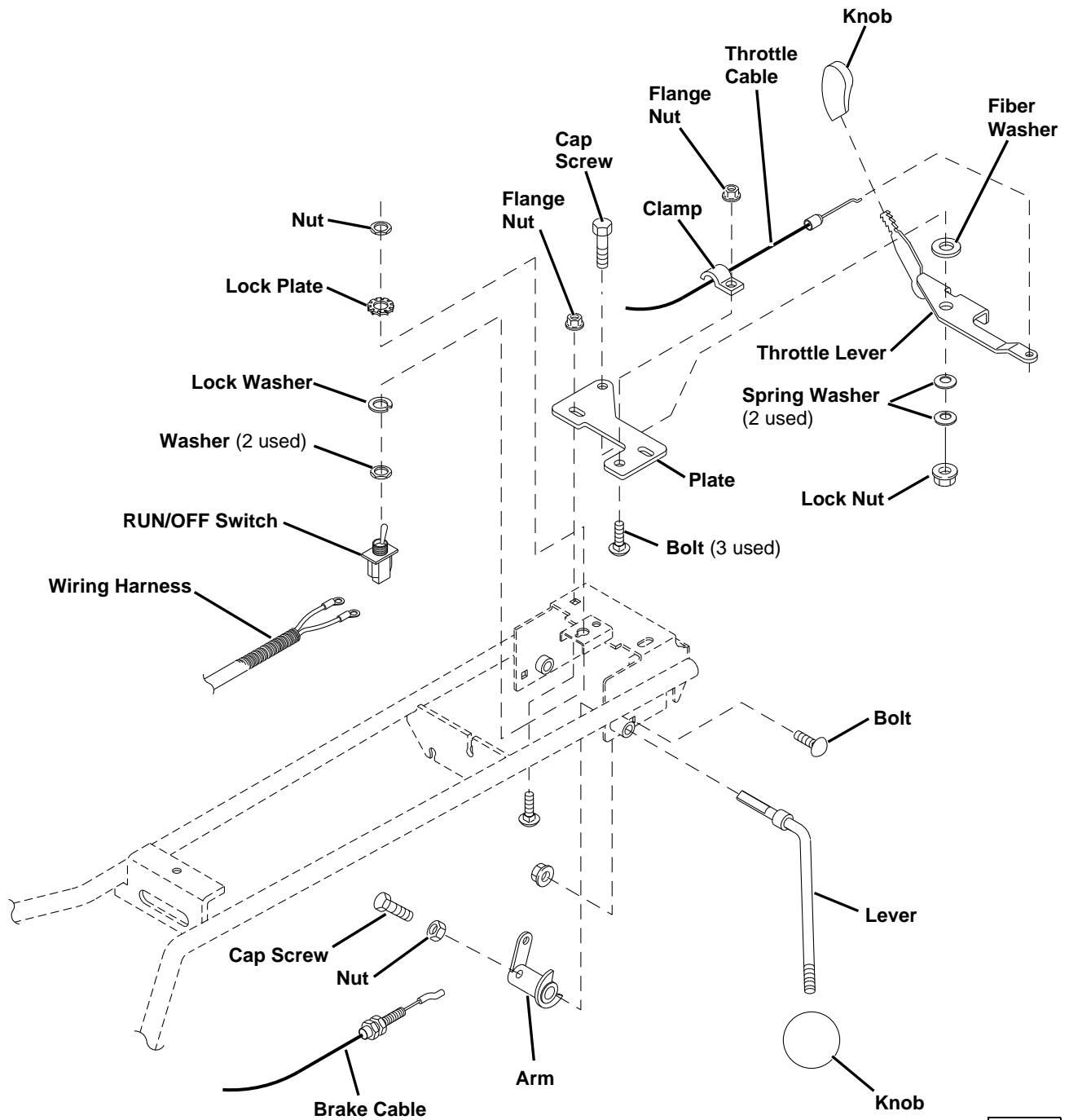

M83784

1. Remove handlebar cover. (See HANDLEBAR COVER—Removal/Installation on page 6-5.)
2. Inspect all parts for wear or damage. Replace parts as necessary.

Installation is done in the reverse order of removal.

- Adjust park brake. (See PARK BRAKE CHECK AND ADJUSTMENT on page 7-7.)
- Adjust throttle cable. (See THROTTLE CABLE CHECK AND ADJUSTMENT on page 3-22.)
- Adjust throttle lever. (See THROTTLE LEVER TENSION ADJUSTMENT on page 6-3.)

CONTENTS

Page

BRAKES

COMPONENT LOCATION AND OPERATION

BRAKE SYSTEM OPERATION..... 7-2

TROUBLESHOOTING CHART.....7-3

DIAGNOSIS

MACHINE WILL NOT MOVE..... 7-4

BRAKE DOES NOT ENGAGE WHEN LEVER ENGAGED..... 7-4

BRAKE DOES NOT HOLD MACHINE 7-5

EXCESSIVE BRAKE WEAR..... 7-6

ADJUSTMENTS

PARK BRAKE CHECK AND ADJUSTMENT..... 7-7

REPAIR

PARK BRAKE CABLE REPLACEMENT..... 7-8

BRAKE BAND REPLACEMENT..... 7-9



COMPONENT LOCATION AND OPERATION

BRAKE SYSTEM OPERATION

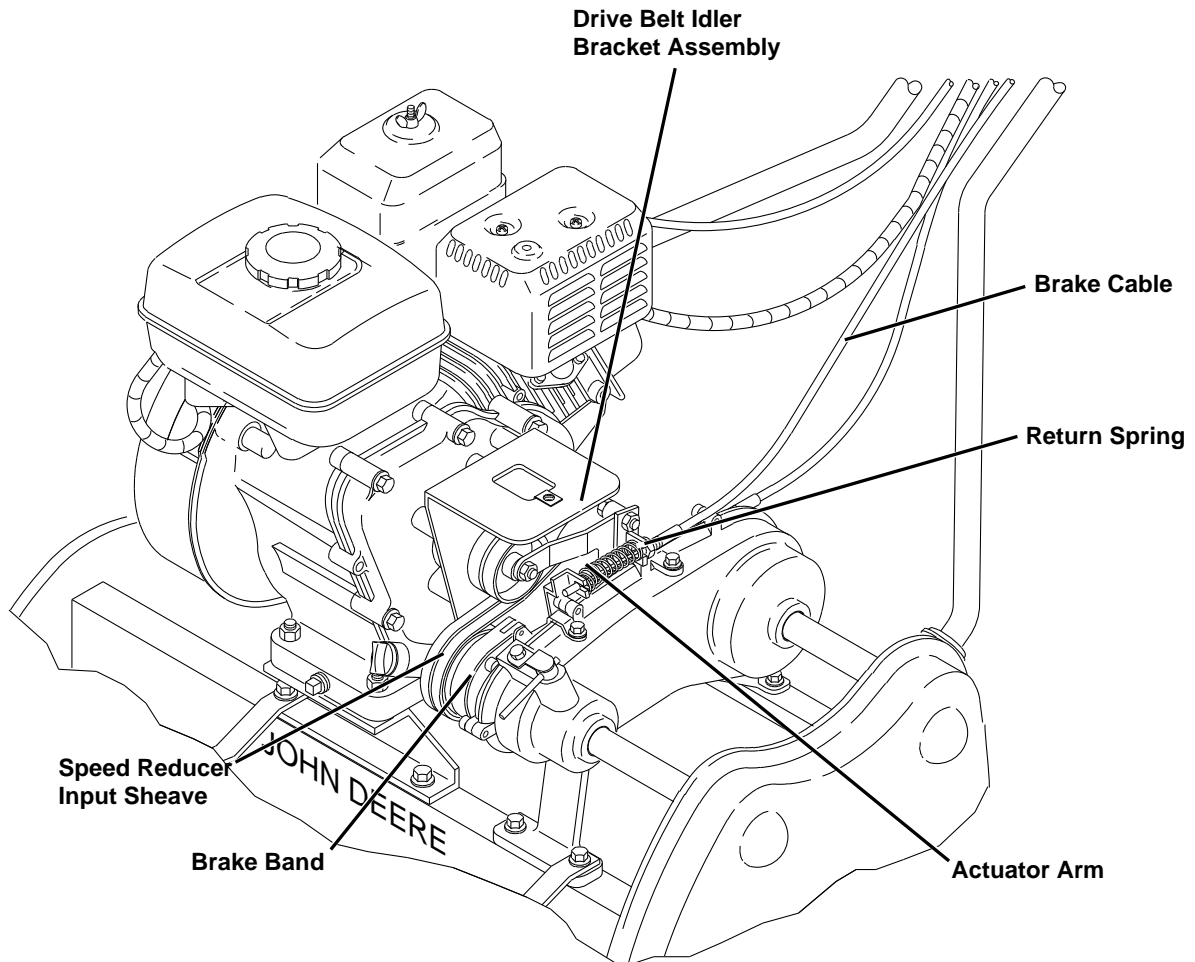

M83939

Function:



To provide a means of preventing the machine from moving when not in operation.

Theory of Operation:

The 220A uses a band-type park brake mounted on the speed reducer input sheave.

When the park brake is engaged, the cable causes the brake band around the speed reducer input sheave to tighten and apply drag, preventing the power train from turning.

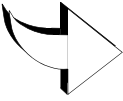
TROUBLESHOOTING CHART

Problem or Symptom  Check or Solution 	Machine will not move.	Brake does not engage when lever engaged.	Brake does not hold machine.	Excessive brake wear.
Cable not adjusted properly.	●	●	●	●
Cable broken or binding.		●		
Brake band/lining worn or contaminated.		●	●	
Return spring broken or missing.	●			●
Speed reducer/drive chain/traction roller damaged			●	
Park brake locked.	●			



DIAGNOSIS

MACHINE WILL NOT MOVE

Test Conditions:

- Machine parked on a level surface.
- RUN/OFF switch OFF position.
- Travel clutch disengaged.
- Reel clutch in STOP position.
- Park brake released.

Test/Check Point	Normal	If Not Normal
1. Park brake lever.	Brake lever not engaged.	Release park brake.
2. Brake cable.	Brake cable properly adjusted.	Adjust cable. (See PARK BRAKE CHECK AND ADJUSTMENT on page 7-7.)
3. Brake cable return spring.	Spring not broken or missing.	Replace return spring.

BRAKE DOES NOT ENGAGE WHEN LEVER ENGAGED

Test Conditions:

- Machine parked on a level surface.
- RUN/OFF switch OFF position.
- Travel clutch disengaged.
- Reel clutch in STOP position.
- Park brake released.

Test/Check Point	Normal	If Not Normal
1. Brake cable.	Brake cable properly adjusted.	Adjust cable. (See PARK BRAKE CHECK AND ADJUSTMENT on page 7-7.)
	Cable not broken or binding.	Replace brake cable. (See PARK BRAKE CABLE REPLACEMENT on page 7-8.)
2. Brake band/lining.	Brake band lining not worn.	Adjust cable, see PARK BRAKE CHECK AND ADJUSTMENT on page 7-7. If brake will still not engage after the adjustment has been performed, replace brake band.(See BRAKE BAND REPLACEMENT on page 7-9.)
	Brake band lining not contaminated.	Clean brake drum and/or replace brake band. (See BRAKE BAND REPLACEMENT on page 7-9.)
	Brake band mounting hardware not loose or missing.	Tighten and/or replace mounting hardware.
3. Actuator arm.	Actuator arm not damaged.	Replace actuator arm. (See DRIVE BELT IDLER BRACKET ASSEMBLY on page 5-27.)

BRAKE DOES NOT HOLD MACHINE

Test Conditions:

- Machine parked on a level surface.
- RUN/OFF switch OFF position.
- Travel clutch disengaged.
- Reel clutch in STOP position.
- Park brake released.

Test/Check Point	Normal	If Not Normal
1. Brake cable.	Brake cable properly adjusted.	Adjust cable. (See PARK BRAKE CHECK AND ADJUSTMENT on page 7-7.)
2. Brake band/lining.	Brake band lining not excessively worn.	Adjust cable, see PARK BRAKE CHECK AND ADJUSTMENT on page 7-7. If brake will still not engage after the adjustment has been performed, replace brake band. (See BRAKE BAND REPLACEMENT on page 7-9.)
	Brake band lining not contaminated.	Clean brake drum and/or replace brake band. (See BRAKE BAND REPLACEMENT on page 7-9.)
3. Speed reducer assembly.	No internal damage.	Repair speed reducer as necessary. (See SPEED REDUCER ASSEMBLY—Disassembly/ Inspection on page 5-17.)
4. Speed reducer output shaft sprocket keys.	Sprocket keys not damaged or missing.	Replace keys.
5. Traction drive chains	Chains not broken.	Replace drive chain(s).
6. Traction roller assembly.	Sprockets not damaged.	Replace sprockets. (See TRACTION ROLLER ASSEMBLY— Disassembly/ Assembly on page 5-25.)
	Keys not damaged or missing.	Replace keys. (See TRACTION ROLLER ASSEMBLY— Disassembly/ Assembly on page 5-25.)



EXCESSIVE BRAKE WEAR

Test Conditions:

- Machine parked on a level surface.
- RUN/OFF switch OFF position.
- Travel clutch disengaged.
- Reel clutch in STOP position.
- Park brake released.

Test/Check Point	Normal	If Not Normal
1. Brake cable return spring.	Spring not broken or missing.	Replace return spring.
2. Brake cable.	Brake cable properly adjusted.	Adjust cable. (See PARK BRAKE CHECK AND ADJUSTMENT on page 7-7.)



CHECKS AND ADJUSTMENTS

PARK BRAKE CHECK AND ADJUSTMENT

Reason:

To ensure that the park brake holds the machine when engaged.

Check Procedure:

1. Park machine on a level surface.
2. Move RUN/OFF switch to OFF position.
3. Move Travel Clutch Lever to NEUTRAL position.
4. Engage park brake.
5. Pull the machine backwards, if the transport wheels/transport roller drag, the brake is adjusted properly. If transport wheels turn, adjust brakes.

Adjustment Procedure:

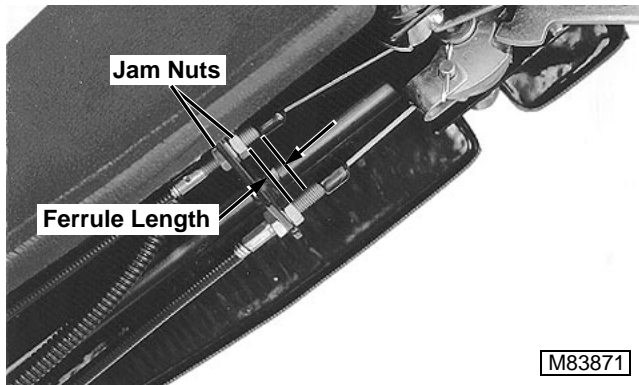

6. Loosen jam nuts (one each side of bracket).
7. Shorten ferrule length.
8. Tighten jam nuts.
9. Repeat CHECK procedure. If additional adjustment is required, go to step 10.

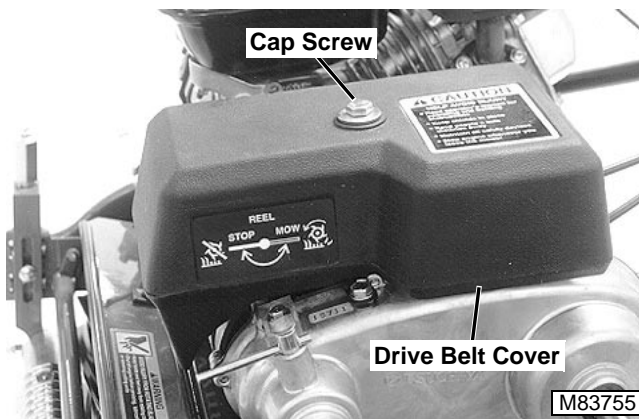

10. Remove cap screw and drive belt cover.

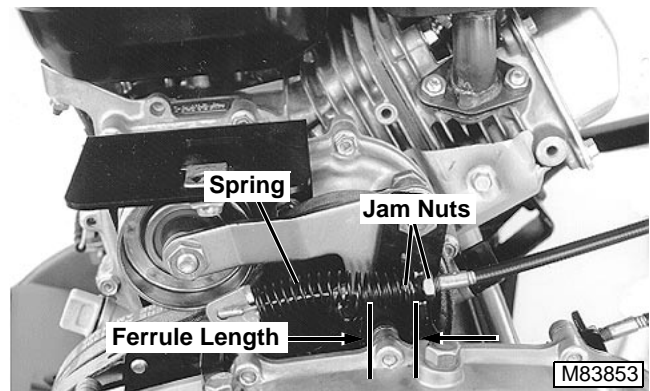

11. Compress spring.
12. Loosen jam nuts holding brake cable at bracket.
13. Shorten ferrule length.
14. Tighten jam nuts.
15. Repeat CHECK procedure. If still not properly adjusted, repeat adjustment procedure.

REPAIR

PARK BRAKE CABLE REPLACEMENT

1. Remove handlebar cover. (See HANDLEBAR COVER—Removal/Installation on page 6-5.)

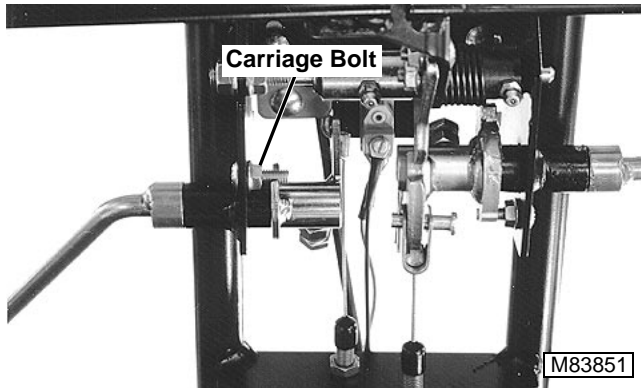

2. Remove carriage bolt and rotate brake lever down.
3. Disconnect cable end from lever.

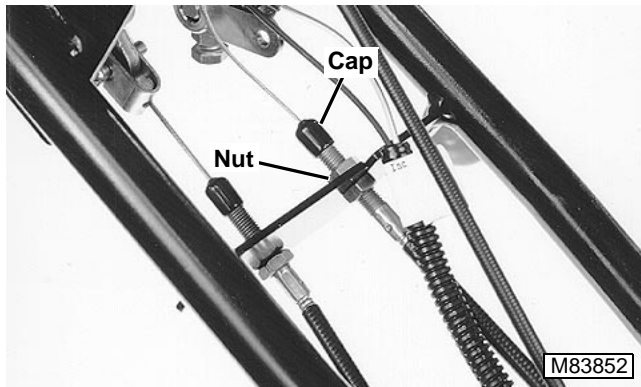

4. Slide cap off cable housing.
5. Remove top nut.
6. Pull cable back until cable housing clears slot.

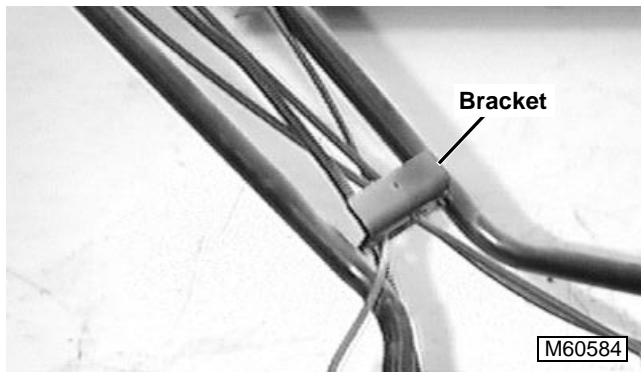

7. Route cable through slotted hole in lower handlebar bracket.

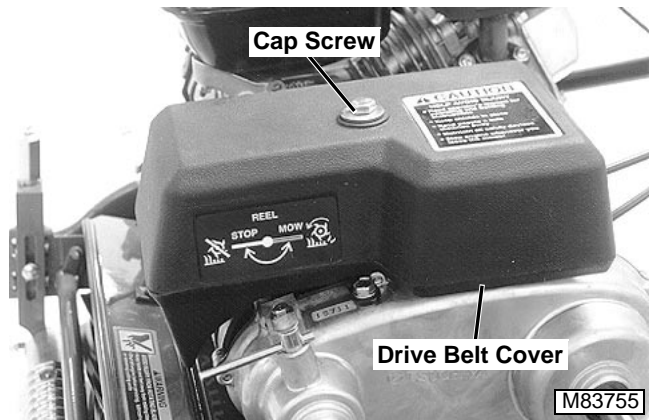

8. Remove cap screw and drive belt cover.

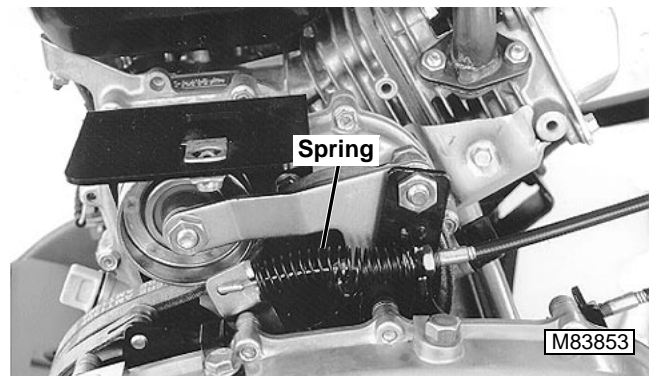

9. Compress spring and disconnect brake cable end from bracket.
10. Remove spring.

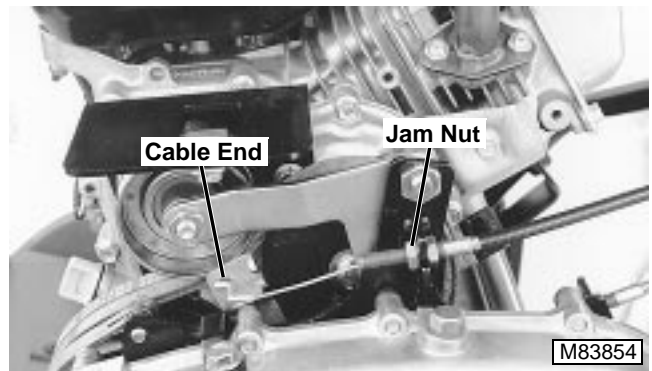

11. Remove jam nut and slide cable from bracket.

Installation is done in the reverse order of removal.

IMPORTANT: Hooked end of brake cable end **MUST** swing freely.

- Apply Multi-Purpose grease to hooked end of brake cable.
- Adjust park brake. (See PARK BRAKE CHECK AND ADJUSTMENT on page 7-7.)

BRAKE BAND REPLACEMENT

1. Remove engine and belts. (See ENGINE—Removal/Installation on page 3-29.)

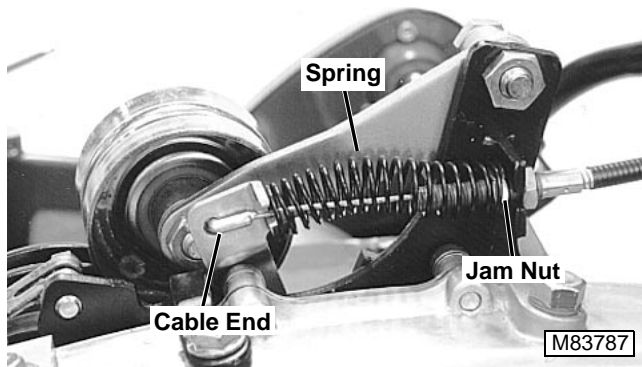

2. Compress spring and disconnect brake cable end from bracket.
3. Remove spring.
4. Remove jam nut and slide cable from bracket.

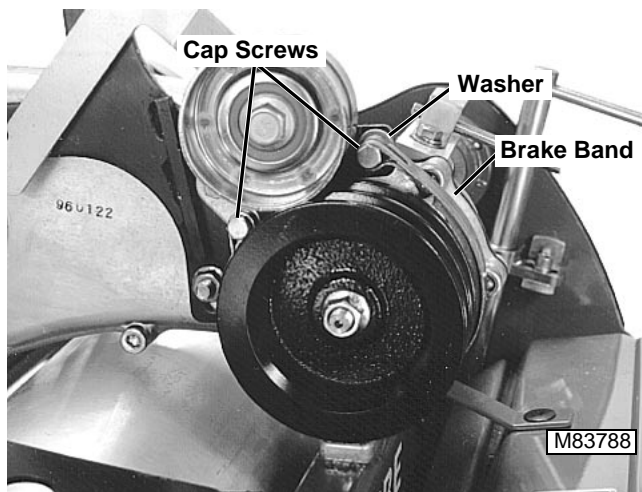

5. Remove caps screws, washer and nuts.
6. Remove brake band.

Installation is done in the reverse order of removal.



This page intentionally left blank.

CONTENTS

Page

CUTTING UNIT

SPECIFICATIONS

GENERAL SPECIFICATIONS.....	8-3
ADJUSTMENT SPECIFICATIONS	8-3
REPAIR SPECIFICATIONS.....	8-3
SPECIAL OR ESSENTIAL TOOLS.....	8-4
DEALER FABRICATED TOOLS	8-4
OTHER MATERIALS.....	8-4
SERVICE PARTS KITS.....	8-4

COMPONENT LOCATION

22-INCH REEL MOWER.....	8-5
-------------------------	-----

TROUBLESHOOTING

TROUBLESHOOTING CHART.....	8-6
----------------------------	-----

DIAGNOSIS

MARCELLING.....	8-7
STREAKING	8-7
CUTTING HEIGHT CHANGES.....	8-8
POOR QUALITY OF CUT.....	8-8
REEL DOES NOT ROTATE.....	8-9
UNIT NOT CUTTING.....	8-9

INFORMATION

BED KNIFE AND REEL RELATIONSHIP	8-10
REEL/BED KNIFE GRINDING	8-10
RELIEF GRINDING.....	8-11
BACKLAPPING.....	8-11
GREENS TENDER CONDITIONER (GTC).....	8-12
SMOOTH ROLLER	8-12
GROOVED ROLLER.....	8-12
PERFORMANCE VARIABLES	8-13

CHECKS AND ADJUSTMENTS

FRAME ALIGNMENT CHECK.....	8-14
BACKLAPPING AND BED KNIFE-TO-REEL ADJUSTMENT.....	8-14
REEL AND BED KNIFE INSPECTION	8-14
BED KNIFE-TO-REEL ADJUSTMENT	8-15
BACKLAPPING PROCEDURE.....	8-16
REEL DRIVE CHAIN TENSION ADJUSTMENT.....	8-17
CUTTING HEIGHT ADJUSTMENT.....	8-17
OPTIONAL GREENS TENDER CONDITIONER (GTC)/ ROTARY BRUSH ADJUSTMENT.....	8-18



	Page
REPAIR	
BED KNIFE	
Removal/Installation.	8-20
REEL ASSEMBLY	
Removal—Without Greens Tender Conditioner (GTC)	8-20
Installation—Without Greens Tender Conditioner (GTC).	8-22
Removal—With Greens Tender Conditioner (GTC).	8-23
Installation—With Greens Tender Conditioner (GTC)	8-25
Bearing Inspection	8-27
Disassembly/Inspection/Assembly.	8-28
FRONT ROLLER	
Removal/Installation.	8-29
Bearing Replacement.	8-30
AET10558 GROOVED ROLLER	
Bearing Replacement.	8-31



SPECIFICATIONS

GENERAL SPECIFICATIONS

Cutting Width	55.9 cm (22 in.)
Cutting Height (Minimum)	
Standard - 3.0 mm bedknife	3.2 mm (1/8 in.)
Optional - 2.5 mm bedknife	2.8 mm (7/64 in.)
Cutting Height (Maximum)	22.2 mm (7/8 in.)
Frequency of Clip	5 mm (0.195 in.)
Reel	
Diameter	127 mm (5 in.)
Number of Blades	11
Material	Heat Treated Special Alloy Steel
Grass Catcher	Rotational Moulded Poly Ethylene
Clip Ratio	
Standard	0.195
Optional	0.155
Front Roller	
Machine Grooved	Standard
Smooth	Optional
Bed Knife Adjustment	Bed Knife-to-Reel

Options:

Greens Tender Conditioner	Standard spacing 6.5 mm (1/4 in.)
Rotary Brush	Optional
Transport Kit	Optional

ADJUSTMENT SPECIFICATIONS

Bed Knife-to-Reel Clearance	0—0.025 mm (0—0.001 in.)
Greens Tender Conditioner (GTC)/Rotary Brush Height	
Rotary Brush	1 mm (1/32 in.) ABOVE Cutting Height
Greens Tender Conditioner	1 mm (1/32 in.) BELOW Cutting Height

REPAIR SPECIFICATIONS

22-Inch Reel Mowers

Bed Knife Top surface5° Relief Angle
Front Surface5° Relief Angle
Reel	Spin Grind 20° Relief Grind

Bed Knife Support

Mounting Screws	6 N•m (53 lb-in.)
---------------------------	-------------------



SPECIAL OR ESSENTIAL TOOLS

NOTE: Order tools according to information given in the U.S. SERVICEGARD™ Catalog or in the European Microfiche Tool Catalog (MTC).

JDG795 Roller Bearing Puller
Used to remove bearings from rollers.

JDG243 or JDG506 Bearing Installer
Used to install bearings.

Two Bolt Gage Bar
Used to perform Height-of-Cut, Rear Roller/Bed Knife and Greens Tender Conditioner Adjustments.

DEALER FABRICATED TOOLS



- 2-in. or 4-in. Paint brush, attach a piece of rubber hose to the handle to extend its length. This will be used to apply backlapping compound.

OTHER MATERIALS

Number	Name	Use
M79292	MPG-2® Multipurpose Polymer Grease Lapping Compound	Apply to engine crankshaft. Used in backlapping Procedure.

SERVICE PARTS KITS

The following kits are available through your parts catalog:

- Smooth Roller Kit
- Grooved Roller Kit
- Rotary Brush or Vertical Cutter Drive Kit
- Vertical Cutter Kit
- Rotary Brush Kit



COMPONENT LOCATION

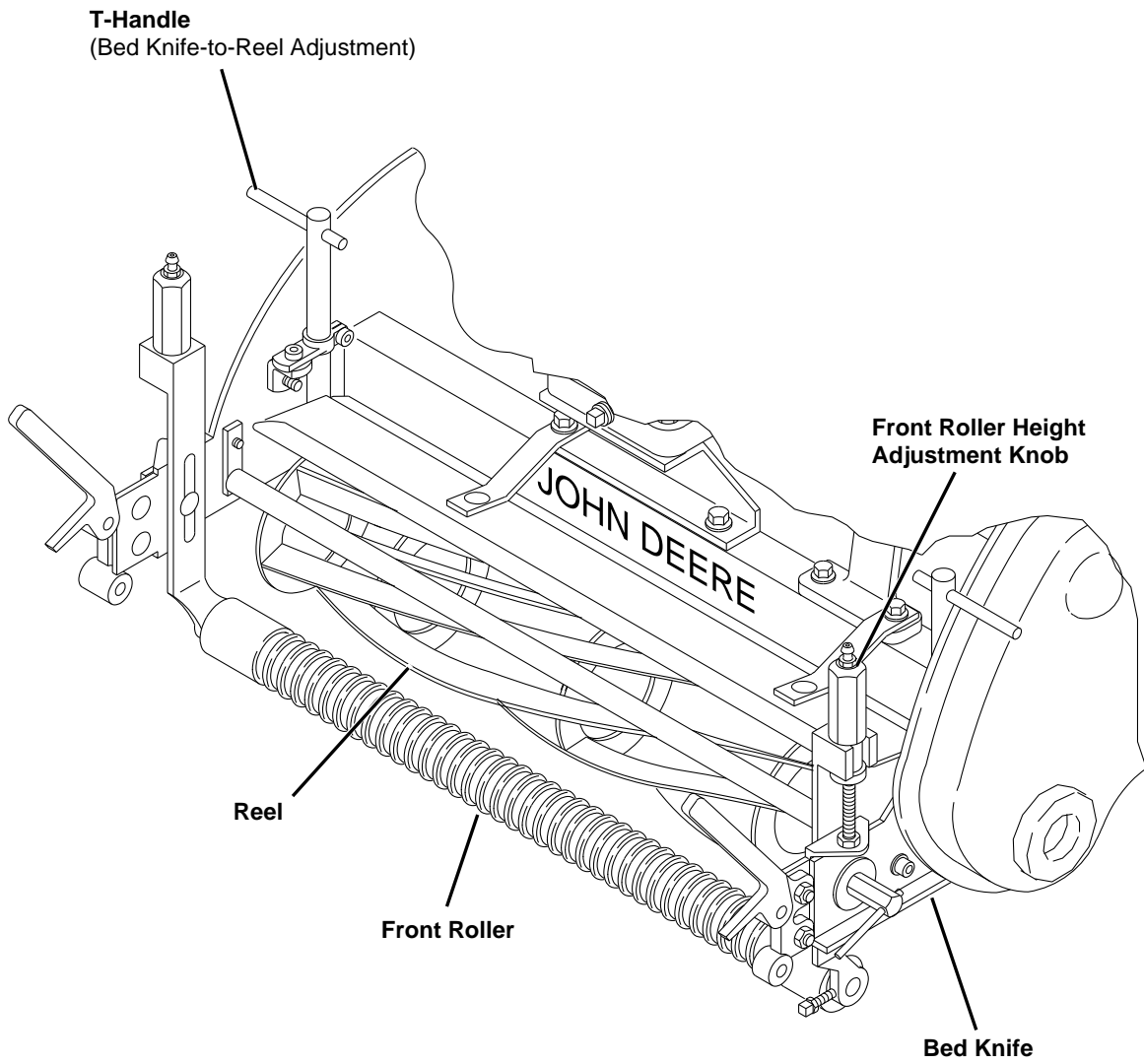

M83941

TROUBLESHOOTING

TROUBLESHOOTING CHART

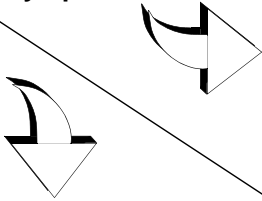
 Problem or Symptom Check or Solution	Marcelling	Streaking	Cutting Height Changes	Poor Cut Quality	Reels Do Not Rotate	Unit Not Cutting						
Reel is dull	●	●										
Incorrect number of blades for conditions	●					●						
Incorrect or inconsistent reel/bed knife clearance		●		●	●	●						
Damaged reel or bed knife		●										
Roller clamp bolt loose			●									
Roller bearing worn			●									
Roller out-of-round			●									
Reel/bed knife dull				●		●						
Reel bearings worn or seized					●							
Machine speed too slow						●						
Grass too wet			●									
Changing soil conditions			●									
Cut grass collecting on roller			●									
Excessive grass growth				●		●						
Chain broken					●							



DIAGNOSIS

MARCELLING

Test Conditions:

- Machine parked on a level surface.
- RUN/OFF switch OFF position.
- Travel clutch disengaged.

Test/Check Point	Normal	If Not Normal
1. Reel	Properly sharpened and backlapped	See BACKLAPPING PROCEDURE on page 8-16.)
	Correct number of blades for application	See PERFORMANCE VARIABLES on page 8-13.

STREAKING

Test Conditions:

- Machine parked on a level surface.
- RUN/OFF switch OFF position.
- Travel clutch disengaged.

Test/Check Point	Normal	If Not Normal
1. Reel/bed knife	Properly sharpened and backlapped	See BACKLAPPING PROCEDURE on page 8-16 .)
2. Reel/bed knife	Clearance properly adjusted across bed knife	Adjust clearance. (See BED KNIFE-TO-REEL ADJUSTMENT on page 8-15.)
3. Reel	Reel not damaged or nicked	Replace reel or perform backlapping procedure. (See REEL ASSEMBLY—Removal—Without Greens Tender Conditioner (GTC) on page 8-20), REEL ASSEMBLY—Removal—With Greens Tender Conditioner (GTC) on page 8-23 or (See BACKLAPPING PROCEDURE on page 8-16.)
4. Bed knife	Bed knife not damaged or nicked	Grind or replace bed knife. (See BED KNIFE—Removal/Installation on page 8-20.)



CUTTING HEIGHT CHANGES^a

Test Conditions:

- Machine parked on a level surface.
- RUN/OFF switch in OFF position.
- Travel clutch disengaged.

Test/Check Point	Normal	If Not Normal
1. Roller clamp bolts	Properly tightened	Adjust cutting height. (See CUTTING HEIGHT ADJUSTMENT on page 8-17.)
2. Roller bearings	Not worn	Replace bearings. (See FRONT ROLLER—Bearing Replacement on page 8-30.)
3. Roller	Not damaged or out-of-round	Replace roller. (See FRONT ROLLER—Removal/Installation on page 8-29.)
4. Roller	Clean, no grass collecting on roller	Install scraper or Power Brush on roller.

POOR QUALITY OF CUT^a

Test Conditions:

- Machine parked on a level surface.
- RUN/OFF switch in OFF position.
- Travel clutch disengaged.

Test/Check Point	Normal	If Not Normal
1. Reel/bed knife	Clearance properly adjusted across bed knife	Adjust clearance. (See BED KNIFE-TO-REEL ADJUSTMENT on page 8-15.)
2. Reel/bed knife	Properly sharpened and backlapped	Sharpen and backlap reel/bed knife (See RELIEF GRINDING on page 8-11 and BACKLAPPING PROCEDURE on page 8-16.)

^aMay have causes related to conditions, see Operator's Manual for more information.

REEL DOES NOT ROTATE

Test Conditions:

- Machine parked on a level surface.
- Key switch OFF position.
- Travel clutch disengaged.

Test/Check Point	Normal	If Not Normal
1. Reel/bed knife	Clearance properly adjusted across bed knife	Adjust clearance. (See BED KNIFE-TO- REEL ADJUSTMENT on page 8-15.)
2. Reel bearings	Not worn or seized	Replace bearings. (See REEL—Disassembly/Inspection/Assembly on page 8-28.)
3. Reel drive chain	Not broken	Replace reel drive chain.
4. Speed reducer reel clutch	Not damaged	Repair clutch. (See SPEED REDUCER—Disassembly/Inspection on page 5-17.)

UNIT NOT CUTTING^a

Test Conditions:

- Machine parked on a level surface.
- RUN/OFF switch in OFF position.
- Travel clutch disengaged.

Test/Check Point	Normal	If Not Normal
1. Reel/bed knife	Clearance properly adjusted across bed knife	Adjust clearance. (See BED KNIFE-TO-REEL ADJUSTMENT on page 8-15.)
2. Reel	Correct number of blades for application	Replace reel with reel having correct number of blades for application. (See PERFORMANCE VARIABLES on page 8-13.)
3. Reel/bed knife	Properly sharpened and backlapped	See BACKLAPPING PROCEDURE on page 8-16 .)

^aMay have causes related to conditions, see Operator's Manual for more information.



INFORMATION

REEL AND BED KNIFE RELATIONSHIP

Reel Mowers are precision machines requiring daily maintenance to maintain the well-groomed appearance of turfgrass. The scissor-like shearing action, that only a reel mower is capable of achieving, is only possible if the reel and bed knife are sharp and the bed knife-to-reel clearance is maintained.

Close examination of the bed knife-to-reel relationship reveals two square edges passing one another with approximately 0.05 mm (0.002 in.) clearance.

There are several reasons why this clearance is necessary.

When the reel is allowed to contact the bed knife, the square (sharp) edges of the reel and bed knife will rollover, becoming dull.

Contact between the reel and bed knife generates heat. Heat generated through this contact will distort the shape of the bed knife. Distortion causes the bed knife to draw closer to the reel, resulting in more rollover of the cutting surfaces and more heat generated in the bed knife.

Drag produced by an improperly adjusted cutting unit may result in an unacceptable clip ratio, undue strain on drive mechanisms and premature wear of the cutting unit.

REEL/BED KNIFE GRINDING

Reasons for grinding:

To restore the cylindrical shape of a reel that has become cone-shaped due to improper adjustment of the bed knife-to-reel clearance or worn reel bearings.

To restore the edge when the grass is not being cut across the entire length of the bed knife, evidenced by streaks of grass left after the mower has passed. Usually the result of nicked blades caused by hitting foreign objects in the grass.

To restore the edge when the lack of frequent backlapping allowed the edge to be rounded beyond the capability of the backlapping procedure to restore the edge.

To restore the edge when the bed knife-to-reel clearance has been improperly adjusted (Reel contacting bed knife).

Cutting action begins as the bed knife positions the grass to be cut at the cutting edge. The reel then pulls the grass towards the bed knife where it is sheared by the cutting edges as they pass one another.

In order for the grass to be cut at the proper height, it must contact the bed knife at the cutting edge. This is accomplished by grinding a 5° relief angle on the front face of the bed knife. Without a relief angle, the blade of grass will contact the lower edge of the bed knife and be bent over at too much of an angle prior to being cut. In the case of mowing greens, where very small cuts are being taken, the reel may not capture the grass at all, and no grass will be cut.

Although some spingrinding machine manufacturers say backlapping is not necessary, John Deere recommends backlapping after spingrinding to remove burrs and rough edges left from the spingrinding procedure. Backlapping produces a honed edge that will cut the grass evenly and leave the tops of the grass with clean, straight edges.

It is important to note, dull cutting edges will tear rather than shear the grass drawn into the bed knife. This will shock the grass plant and retard its growth.



RELIEF GRINDING

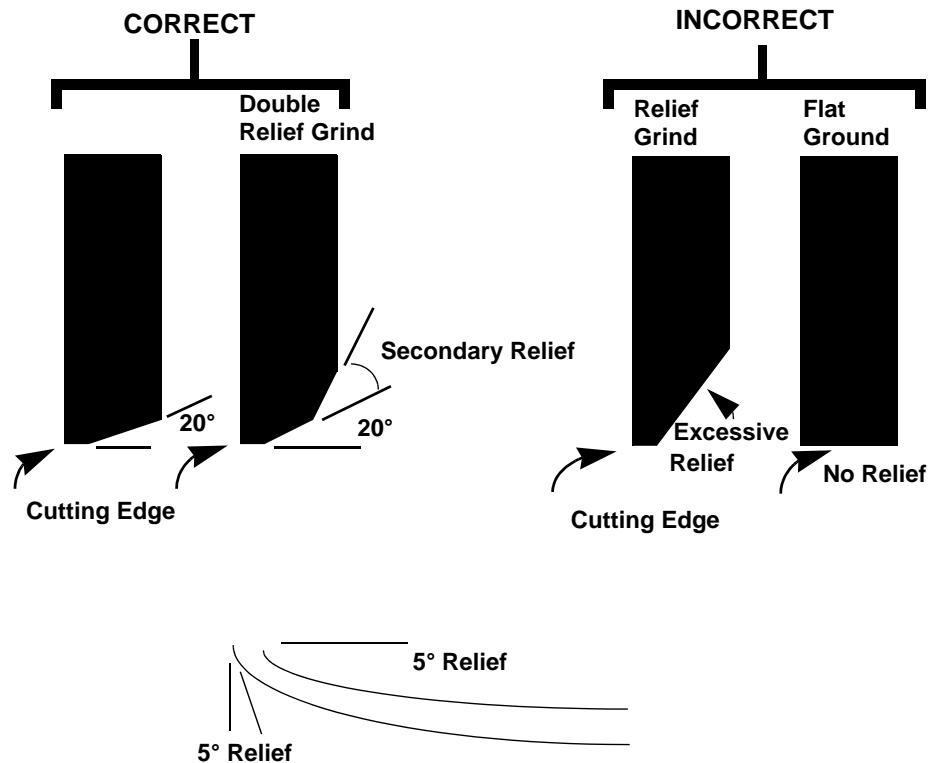

John Deere recommends Relief Grinding the reel and bed knife for these reasons:

- Reduced blade contact area, results in less friction, requiring less horsepower to drive the reel.
- Ensures longer wear life.
- Less time is required to backlap.
- Reduces pulling and tearing of the grass as the unit gets dull by use.
- Provides an area for backlapping compound to be trapped to more effectively backlap reels.
- Relief grinding removes metal from the trailing edge of the blade forming an angle (Relief Angle) to reduce the contact.
- Area of the cutting edges.
- Because of the relief grind it is possible, with backlapping, to true a reel (make it round) if a blade is 0.025—0.05 mm (0.001—0.002 in.) too high.



BACKLAPPING

This procedure is used to maintain a sharp cutting edge between grindings. See Reel/Bed Knife Grinding, in this section, to determine if grinding is necessary.

Backlapping, when compared to grinding, removes a very small amount of metal, requires less time and will effect a smooth, clean cut.

The backlapping procedure is accomplished by spinning the reel backwards while applying special abrasive compounds to the reel.

Usually, course compounds are used initially, followed by a fine abrasive "tournament grade" for final honing. Recommended grits for greens and tees when using the 22-in. cutting units are 120, 180 and 220.

Recommended compounds for fairways are 60, 80 and 100 grit. Reel sharpening compounds should not be toxic, oily or greasy.

The cutting unit should be inspected, lightly backlapped, adjusted and checked every 20 hours. of operation for a uniform cut along the complete length of the bed knife.

It is important that the adjustment allows the reel to turn freely without dragging against the bed knife. Metal-to-metal contact will generate heat, causing the reel to expand and intensifying the dragging that produces more heat.

GREENS TENDER CONDITIONER (GTC)

The conditioning process involves shallow vertical cutting. The blades are adjusted to cut runners and lift horizontal leaf material. It is important not to use a GTC for three days following Top Dressing. It is also important that frequent and thorough observations be performed or stress to the plants may occur. Stress has occurred when a yellow or brown tint is observed in the color of the grass.

Grass is conditioned initially with the blades set 0.8 mm (1/32 in.) below height-of-cut.

The green is then examined closely for inconsistencies or appearance of over-aggressiveness. GTC penetration should be decreased if indications are present.

After 1 to 2 hours the green is checked for stress. If visible stress is observed, GTC penetration is decreased to 0.25 mm (1/64 in.) below height-of-cut.

Conditioning is continued at this setting for three to five days checking frequently for signs of stress. If no stress is observed, GTC penetration is increased by 0.25 mm (0.010 in.) while observing every two to three days for signs of stress.

Stress is a cumulative result of many factors such as irrigation, temperature, humidity, chemical application etc. Conditioning aggressiveness will require adjustment and monitoring as these factors vary. Conditioning frequency may also need to be reduced in some cases.

SMOOTH ROLLER

The roller is used as a ground sensing device to detect changes in the contour of the turf as the mower moves forward.

A smooth roller is always used on the rear of a cutting unit to establish the cutting height range. A front roller used in conjunction with a rear roller is needed to achieve more exact cutting heights.

GROOVED ROLLER

The grooved roller is used as a ground sensing device to detect changes in the contour of the turf as the mower moves forward. The main advantage in using a grooved roller rather than a smooth one comes when cutting long grass that is very wet. Grass that is wet will tend to stay down rather than spring up after the roller passes. Grooved rollers will not bend the grass over, allowing it to be cut rather than passed over.

Along with advantages come disadvantages. Because of the reduced contact area, inherent with a grooved roller, the roller may penetrate deeper into the soil, (especially in wet conditions) lowering the effective cutting height and possibly scalping the turf. Serious consideration should be given to mowing Greens with a smooth roller attached, especially when the turf is very wet.



PERFORMANCE VARIABLES

Three performance variables that affect the quality of cut are:

- Number of reel blades (9 or 11)
- Reel rpm (sprockets)
- Ground speed of machine (sprockets)

NOTE: When discussing performance variables, we must assume that other factors such as rate of growth, mowing frequency, soil fertility and equipment condition have been considered and are not affecting the quality of cut.

Terms to help understand Performance Variables:

Shear point - A single point of cutting contact between the cutting unit and the turf. Due to the Reel mower design, there are an infinite number of shear points across the bed knife.

Clip Ratio (CR) - The forward distance traveled between successive cutting contacts at any one shear point.

Cutting Height (CH) - The distance above the soil line that grasses are clipped.

Since reel speed is directly coupled to ground speed the Clip Ratio (CR) is fixed at 4.93 mm (0.195 in.).

When cutting greens, marcelling will be noticeable if the Clip Ratio is greater than 6.35 mm (0.25 in.).

Between 6.35 mm (0.25 in.) and 5.08 mm (0.2 in.), marcelling is seldom a problem. The 220A comes with a standard Clip Ratio of 4.93 mm (0.195 in.). We feel that this is the optimum Clip Ratio. Above 5.08 mm (0.2 in.), marcelling may become noticeable. The reel speed can be increased to reduce the Clip Ratio to 3.94 mm (0.155 in.). However, reel and bedknife life will be reduced. Even more importantly, under certain environmental conditions, the lower Clip Ratio can result in turf damage. This damage will appear as a brown strip where the mower overlaps on each pass.

NOTE: To calculate MPH, multiply 0.68148 x ft. traveled/second. Another way to calculate speed is to measure off an 88 ft. distance, record the length of time, in seconds, it takes to travel that distance and divide 60 by that time.



CHECKS AND ADJUSTMENTS

FRAME ALIGNMENT CHECK

Reason:

To detect and eliminate non-parallelism which can result in step cutting.

Equipment:

- Feeler Gauge Set (Blade Type)
- Flat Plate

Procedure:

1. Park machine on a level surface.
2. Move RUN/OFF switch to OFF position.
3. Move travel clutch Lever to NEUTRAL position.
4. Engage park brake.
5. Release operator presence bail to disengage reel drive.
6. Remove transport wheels (if equipped). (See TRANSPORT WHEELS on page 9-3.)
7. Install new bed knife and adjust reel to zero clearance. (See BED KNIFE-TO-REEL ADJUSTMENT on page 8-15).
8. Set mower on a flat surface plate. The mower should sit on drive rollers and bed knife with front roller hanging over the edge of plate.
9. With one end of bed knife touching the surface plate, check for gap between reel and surface plate at each end using a feeler gauge. If gap exceeds 0.13 mm (0.005 in.), adjust traction roller. (See TRACTION ROLLER ADJUSTMENT on page 5-11.)



BACKLAPPING AND BED KNIFE-TO-REEL ADJUSTMENT

It is best to think of backlapping and bed knife-to-reel adjustments as one procedure. Although backlapping removes only a small amount of metal, the clearance between the reel and bed knife increases due to backlapping and must be readjusted.

Another very important point to remember is that adjustments can only be successful if the frame integrity (straightness and strength) is maintained. Attaching bolts must be secure and bearings must be well lubricated and not worn.

REEL AND BED KNIFE INSPECTION



CAUTION

Always wear protective gloves when working on or near the reel or bed knife. Severe personal injury can result from contact with the sharp cutting edges.

Never allow more than one person at a time, to work on any one cutting unit. Never allow work to be accomplished on more than one cutting unit at the same time. Serious personal injury could result.

1. Visually inspect cutting unit for damage. Chipped paint, dents or gouges may indicate the need for a closer look at the frame for distortion, broken weldments or other damage that could prevent proper adjustment. Repair or replace parts as necessary.
2. Inspect for vertical or lateral movement in the reel or bearings supporting the reel, repair or replace as necessary.
3. While rotating the reel in the reverse direction by hand, inspect each blade cutting edge for nicks, gouges or distortion. Ensure the cutting edge land does not exceed more than 3/4 of the blade thickness. See REEL/BED KNIFE GRINDING on page 8-10 to restore the relief angle and cutting edge before continuing with this procedure.

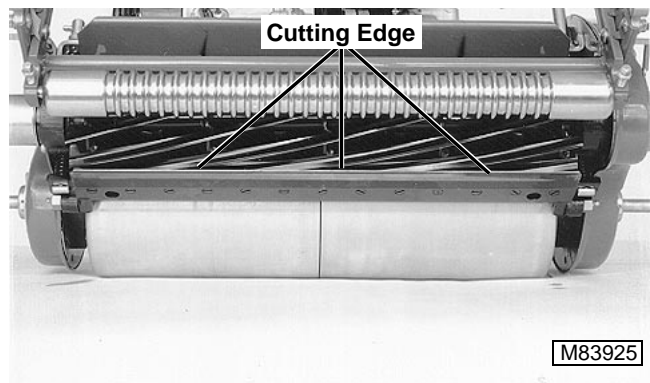

4. Inspect the bed knife cutting edge for nicks, gouges or distortion. Inspect leading edge of bed knife for relief to prevent catching of knife. A small relief or dub needs to be added after several backlappings.
5. Inspect the bed knife for uneven wear (indicated by uneven land width across the length of the bed knife). Ensure the cutting edge land does not exceed 3/4 of the cutting edge. Replace the bed knife if the cutting edge starts curling upward.

BED KNIFE-TO-REEL ADJUSTMENT

Reason:

To ensure correct contact between bed and reel knife.

Equipment:

- Feeler Gauge Set (Blade Type)

Procedure:



CAUTION

Always wear protective gloves when working on or near the reel or bed knife. Severe personal injury can result from contact with the sharp cutting edges.

NOTE: Reel must be free to turn by hand.

1. Park machine on a level surface.
2. Move RUN/OFF switch to OFF position.
3. Move Travel Clutch Lever to NEUTRAL position.
4. Engage park brake.
5. Disengage reel clutch.
6. Remove grass catcher.

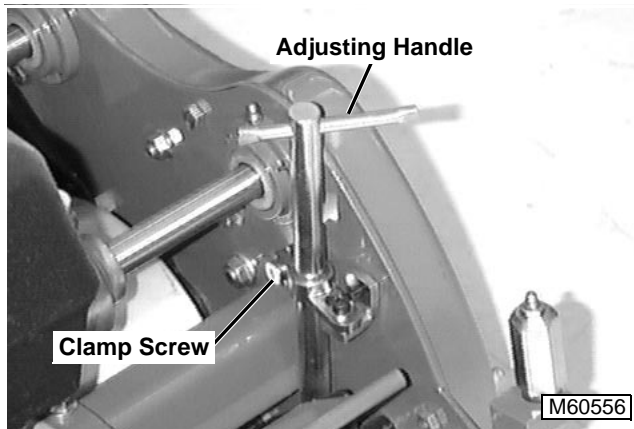

7. Loosen clamp screw on both sides of mower.
8. To adjust bed knife-to-reel clearance turn adjusting handle:
 - CLOCKWISE to decrease clearance.
 - COUNTERCLOCKWISE to increase clearance.

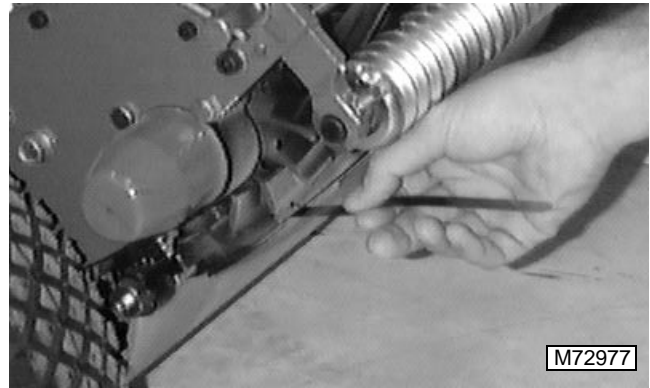

IMPORTANT: Always rotate reel in the reverse direction to avoid damaging or dulling the cutting edges or the reel or bed knife.

9. Inspect gap along the entire length of the bed knife using a 0.002-in feeler gauge:
 - If the reel contacts the bed knife at any point, go to step 11.
 - If the gap is large enough to allow the feeler gauge to pass between reel and bed knife, go to steps 12—13.
10. Slowly rotate the reel backwards and watch for contact between the reel and bed knife at the center of the bed knife. If contact is made, backlap the reel and bed knife to eliminate "FROWN" in bed knife or out-of-round condition of reel. (See BACKLAPPING PROCEDURE on page 8-16.)

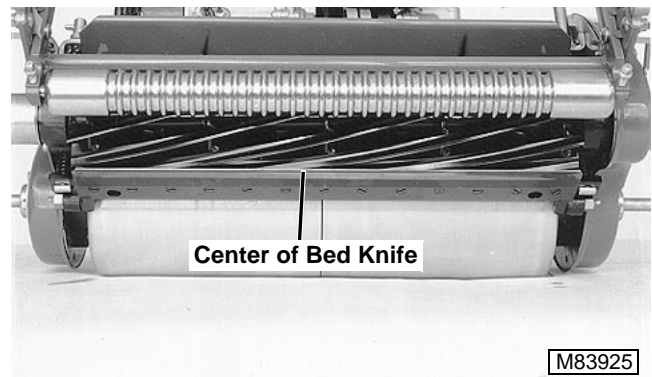

11. Measure the clearance at the center of bed knife. If clearance exceeds 0.05 mm (0.002 in.), backlap the reel and bed knife to eliminate "SMILE" in bed knife or out-of-round condition of reel. (See BACKLAPPING PROCEDURE on page 8-16.)
12. When properly adjusted and sharpened, each reel blade should cut a piece of paper held at 90° to the top surface of the bed knife along the entire length of the bed knife with **0—0.025 mm (0—0.001 in.)** clearance



IMPORTANT: DO NOT overtighten knife to reel. Overtightening can cause damage to knife or cutting edges.

13. Tighten clamp screw on both sides of mower.

BACKLAPPING PROCEDURE

Reason:

To ensure consistent cutting action.

Equipment:

- Long-Handled Brush (Dealer Fabricated)
- Backlapping Unit
- 3/8-in. Backlapping Bolt

Procedure:



CAUTION

Disengage GREENS TENDER CONDITIONER before backlapping. Severe personal injury may result from rotating knives.

IMPORTANT: Backlap cutting reel routinely to prolong life of reel.

NOTE: The bed knife-to-reel contact should be adjusted before performing backlapping procedure. (See BED KNIFE-TO-REEL ADJUSTMENT on page 8-15.)



CAUTION

Avoid injury from rotating blades. Keep hands and feet away from blades while machine is running.

Always wear protective gloves when working on or near the reel or bed knife. Severe personal injury can result from contact with the sharp cutting edges.

Never allow more than one person at a time, to work on any one cutting unit.

Never allow work to be accomplished on more than one cutting unit at the same time. Serious personal injury could result.

1. Park machine on a level surface.
2. Move RUN/OFF switch to OFF position.
3. Move Travel Clutch Lever to NEUTRAL position.
4. Engage park brake.
5. Release operator presence bail to disengage reel drive.

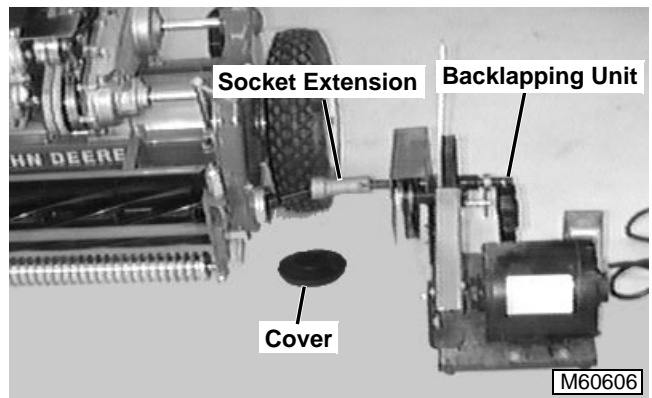

6. Remove reel shaft cover.
7. Screw 3/8-in. backlapping bolt into reel shaft.
8. Install socket extension on backlapping bolt.
9. Connect extension to backlapping unit.
10. Turn on backlapping motor. Make sure reel is running in reverse.

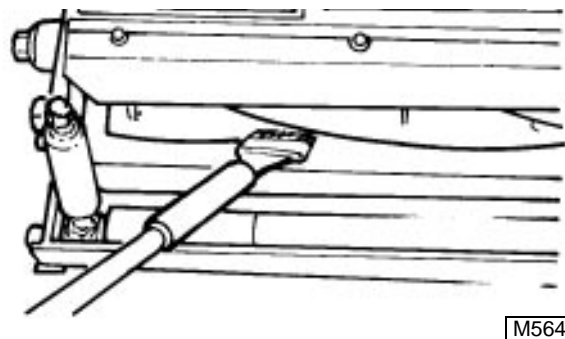

M56482

IMPORTANT: Never operate cutting unit in the Forward direction until abrasive compounds are removed from the cutting unit. The abrasive compound will dull the cutting edges

11. Apply 120 grit compound to the rotating reel evenly from one side to the other and back again with a long handled brush. (See DEALER FABRICATED TOOLS on page 8-4 for instructions for making this tool.)
12. Allow the reel to spin until quiet. If desired, follow with a 220 grit compound to achieve a "Tournament Grade" finish.



CAUTION

Never use pressure washers or steam cleaners to rinse the abrasives from the cutting unit. The abrasives may be forced past the seals and damage the bearings.

13. Rinse the lapping compound off the cutting unit with water and repeat the Adjustment Procedure before returning the unit to service. (See BED KNIFE-TO-REEL ADJUSTMENT on page 8-15.)
14. Add a relief if needed, to the leading edge of the knife, to prevent the edge from "catching" the reel and curling it up.

REEL DRIVE CHAIN TENSION ADJUSTMENT

Reason:

To maintain proper chain tension.

Procedure:



CAUTION

Block machine securely before servicing or repairing.

1. Park machine on a level surface.
2. Move RUN/OFF switch to OFF position.
3. Move Travel Clutch Lever to NEUTRAL position.
4. Engage park brake.
5. Disengage reel clutch.
6. Remove transport wheels and left side drive collar (if equipped). (See TRANSPORT WHEELS on page 9-3.)

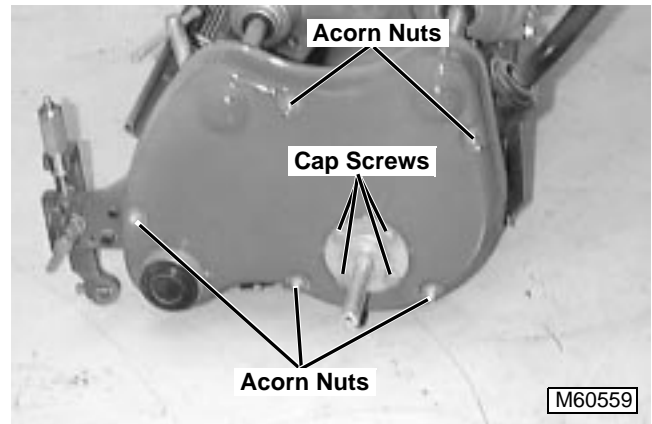

7. Loosen four bearing housing cap screws.
8. Remove five acorn nuts, washers and shoulder bolts, and remove left drive cover.

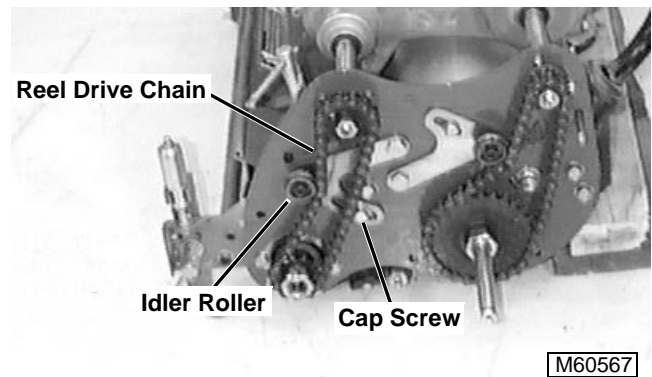

9. Loosen cap screw and reposition idler roller/bracket until chain deflects **6 mm (0.225 in.)** at mid span opposite idler.
10. Tighten cap screw.
11. Install cover and transport wheels (if equipped).

CUTTING HEIGHT ADJUSTMENT

Reason:

To set desired cutting height.

Procedure:

NOTE: The bed knife-to-reel adjustment MUST be performed before adjusting cutting height. (See BED KNIFE-TO-REEL ADJUSTMENT on page 8-15.)

1. Park machine on a level surface.
2. Move RUN/OFF switch to OFF position.
3. Move Travel Clutch Lever to NEUTRAL position.
4. Engage park brake.
5. Disengage reel clutch.



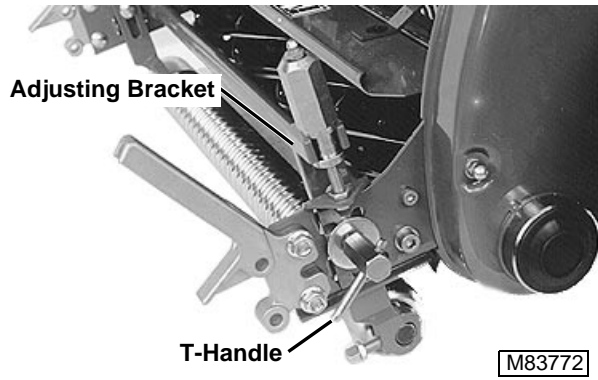

6. Loosen T-handle on both sides of mower until adjusting bracket slides easily.

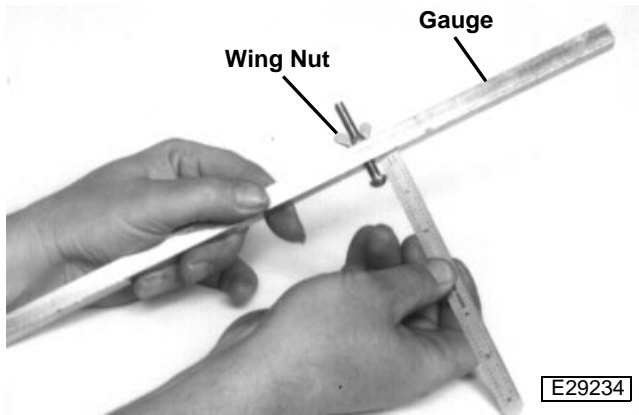

7. Loosen wing nut and set gauge to desired cutting height.

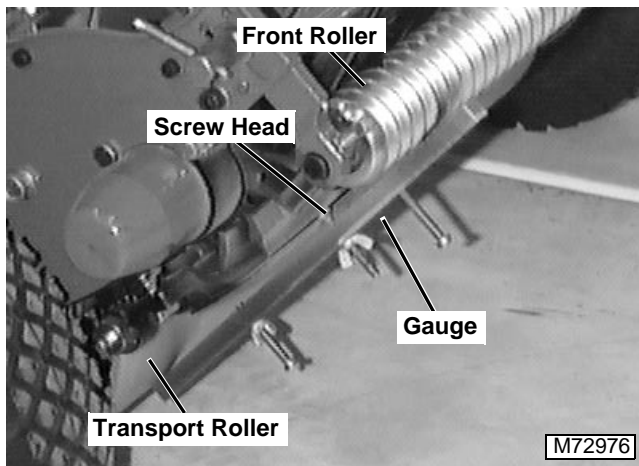

8. Place gauge against bottom of front and transport rollers and bed knife cutting surface.

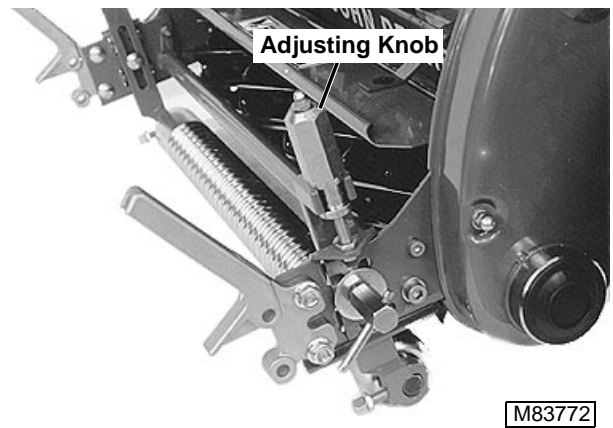

- 9. Adjust height front roller up or down using adjusting knob.
- 10. Adjust height to gauge by adjusting front roller until knife make firm contact with underside of screw head.
- 11. Repeat steps 8—10 for other side.
- 12. Recheck cutting height on both sides with gauge. Re-adjust if necessary.
- 13. Tighten T-handles.

OPTIONAL GREENS TENDER CONDITIONER (GTC)/ROTARY BRUSH ADJUSTMENT

Reason:

To ensure that the machine drives evenly when the Rotary Brush or Greens Tender Conditioner (GTC) is engaged.

Procedure:

- 1. Park machine on a level surface.
- 2. Move RUN/OFF switch to OFF position.
- 3. Move Travel Clutch Lever to NEUTRAL position.
- 4. Move reel clutch to STOP position.
- 5. Engage park brake.
- 6. Disengage Greens Tender Conditioner (GTC).
- 7. Remove grass catcher.

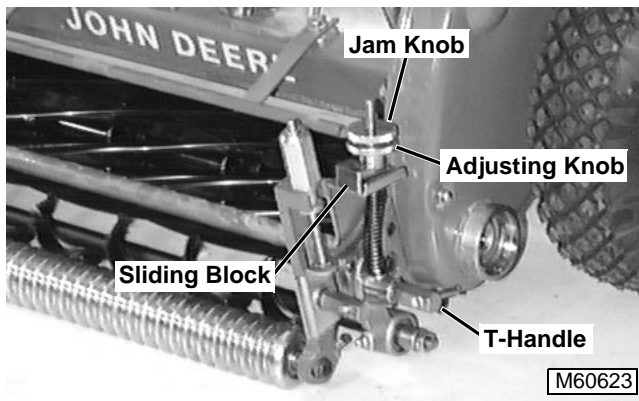

8. Loosen T-handle.
9. Loosen jam knob.
10. Set adjusting knob on lower step of sliding block.
11. Repeat procedure for other side.

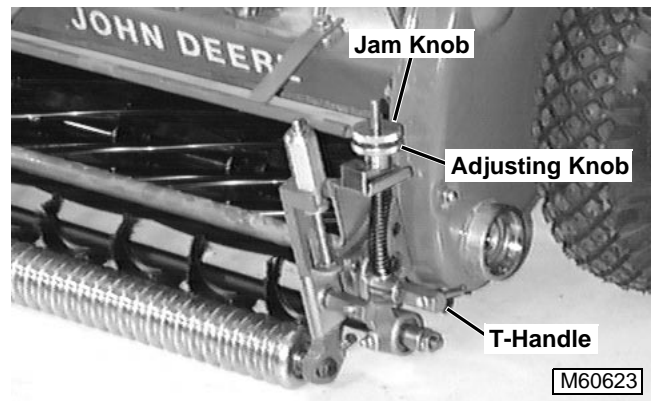

15. Use adjusting knob to set height on each side.
16. Tighten jam knob.
17. Repeat for other side.

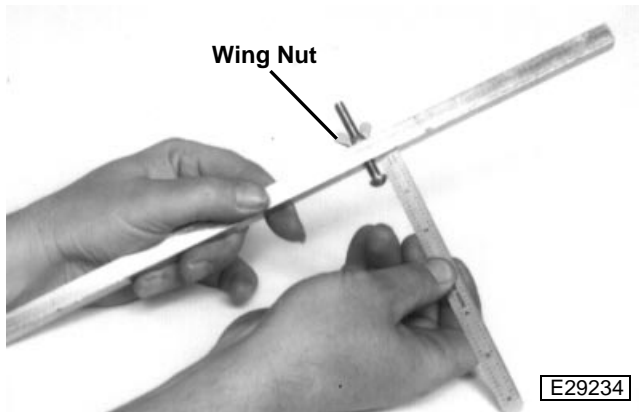

12. Measure from the top of screw head to the top of the gauge. Set to desired cutting height.
13. Loosen wing nut and adjust the screw as follows:
 - **Rotary Brush:** 1 mm (1/32 in.) ABOVE cutting height.
 - **Greens Tender Conditioner:** 1 mm (1/32 in.) BELOW cutting height.

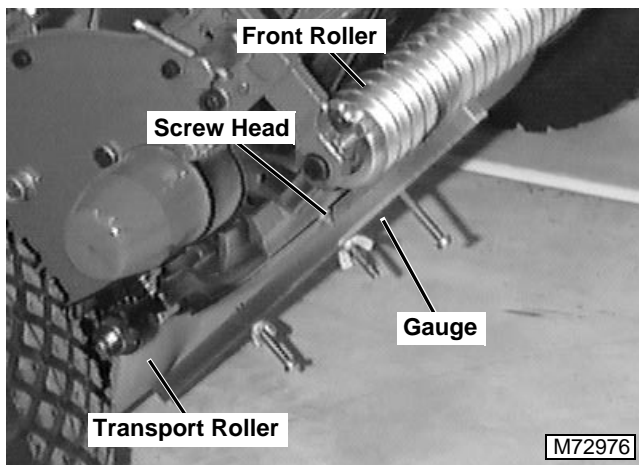

14. Place gauge against bottom of front and rear rollers and bed knife cutting surface.



REPAIR

BED KNIFE

Removal/Installation

**CAUTION**

Block machine securely before servicing or repairing.

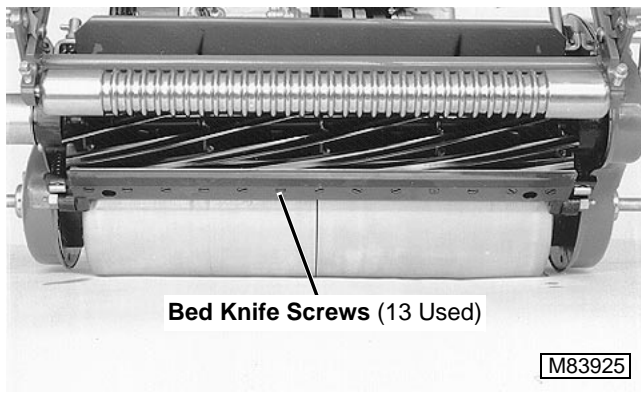
**CAUTION**

Always wear protective gloves when working on or near the reel or bed knife. Severe personal injury can result from contact with the sharp cutting edges.

1. Remove 13 screws and bed knife.

IMPORTANT: DO NOT reuse screws if bed knife is removed.

2. Remove debris and corrosion from bottom surface of shoe. Check the bed knife mounting surface with a straight edge for distortion, straighten or replace as necessary.

Installation is done in the reverse order of removal.

- Install bed knife using new screws. Starting at the center screw, alternate tightening bed screws working toward the ends of the knife. Tighten screws to **6.5 N•m (58 lb-in.)**.

REEL ASSEMBLY

Removal—Without Greens Tender Conditioner (GTC)

**CAUTION**

Block machine securely before servicing or repairing.

1. Remove transport wheels and drive collars (if equipped). (See TRANSPORT WHEELS on page 9-3.)

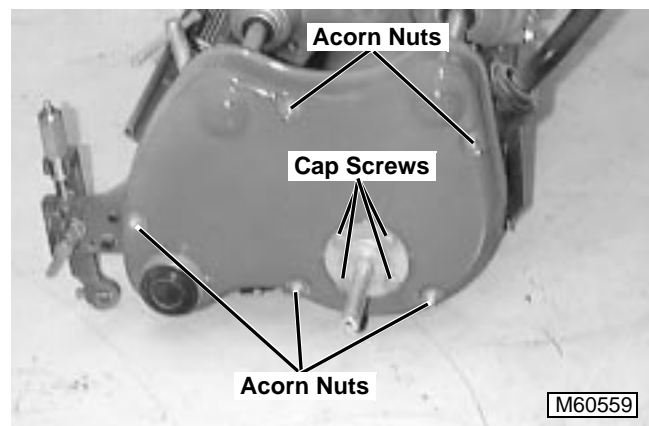

2. Loosen four bearing housing cap screws.
3. Remove five acorn nuts, washers and shoulder bolts, and remove left drive cover.

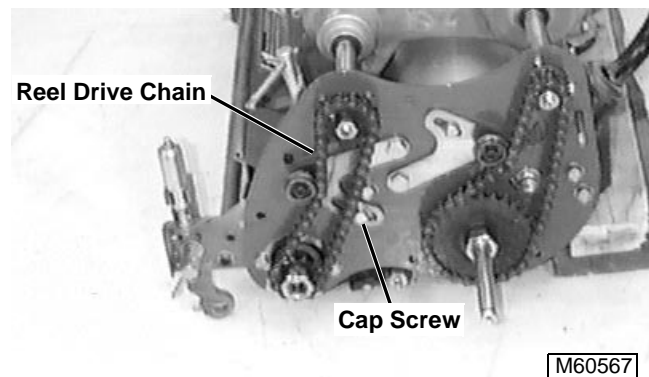

4. Loosen cap screw to release chain tension.
5. Disconnect master link and remove reel drive chain.



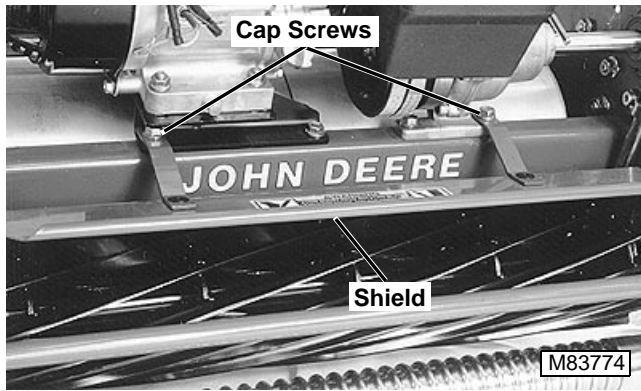

6. Loosen cap screws and remove shield.

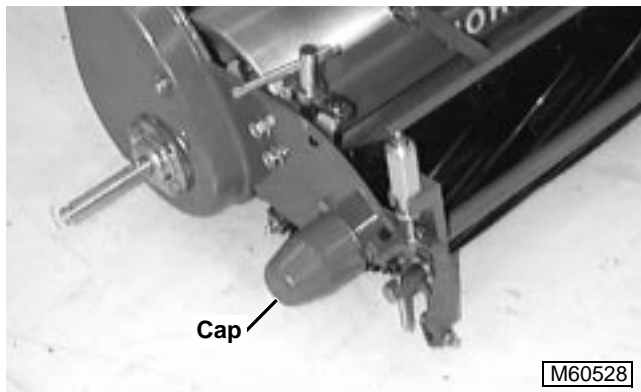

7. Remove cap

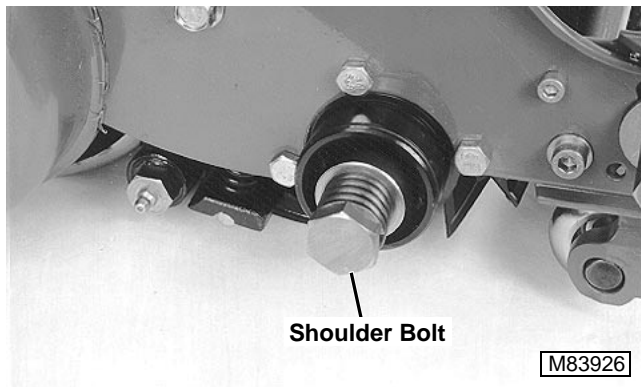

8. Remove shoulder bolt, spring, spacer and collar.

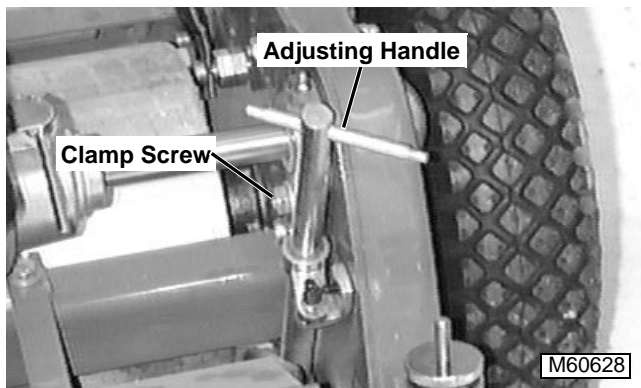

9. Loosen clamp screw and remove bed knife adjusting handles from both sides of mower.

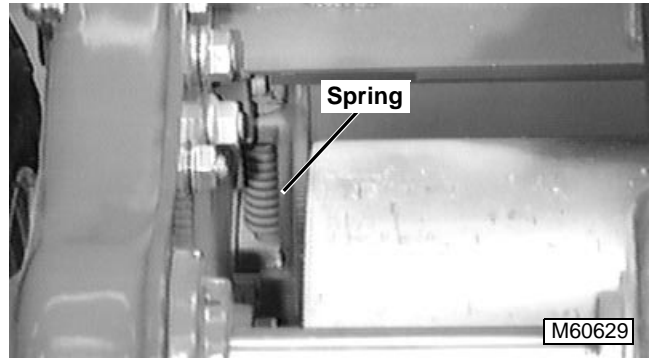

10. Remove spring and T-bolt from both sides of mower.

11. Rotate bed knife support downward.

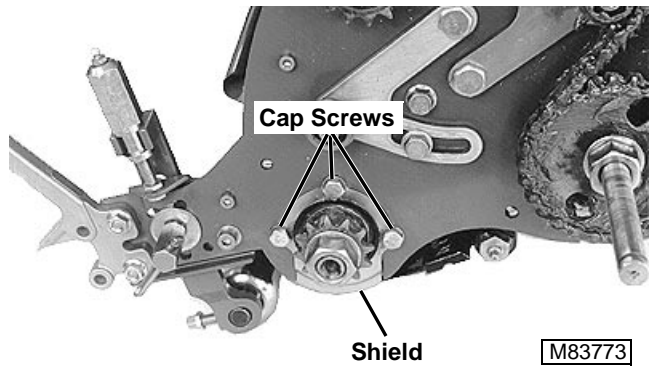

⚠ CAUTION

Always wear protective gloves when working on or near the reel or bed knife. Severe personal injury can result from contact with the sharp cutting edges.

12. Remove three cap screws and shield from left bearing housing. Left end of reel will lower.

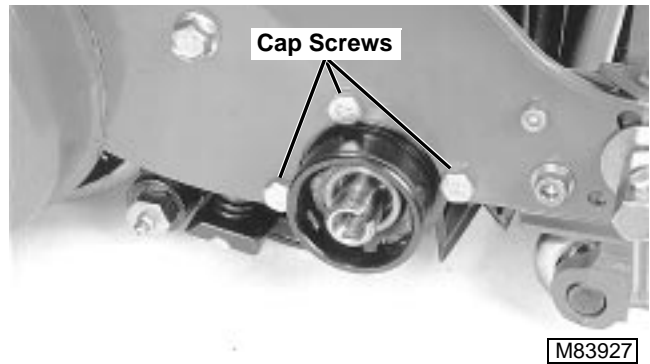

13. Remove three bolts from right bearing housing.

14. Remove reel assembly.

15. Inspect all parts for wear or damage. Replace parts as necessary. (See Disassembly/Inspection/Assembly procedure on page 8-28.).



Installation—Without Greens Tender Conditioner (GTC)



CAUTION

Always wear protective gloves when working on or near the reel or bed knife. Severe personal injury can result from contact with the sharp cutting edges.

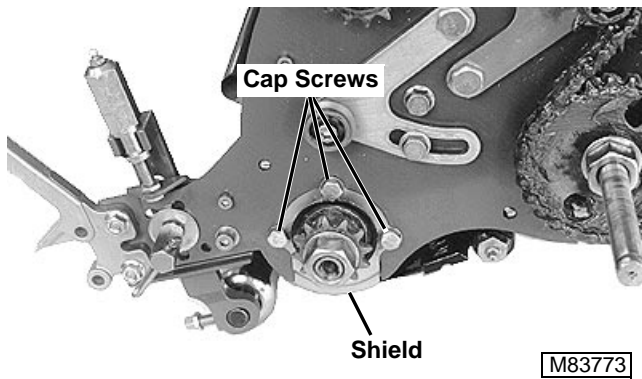

1. Install reel assembly and shield with three cap screws.

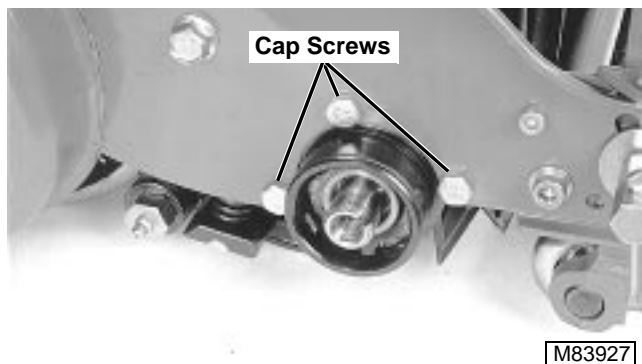

2. Install bearing housing using three cap screws.

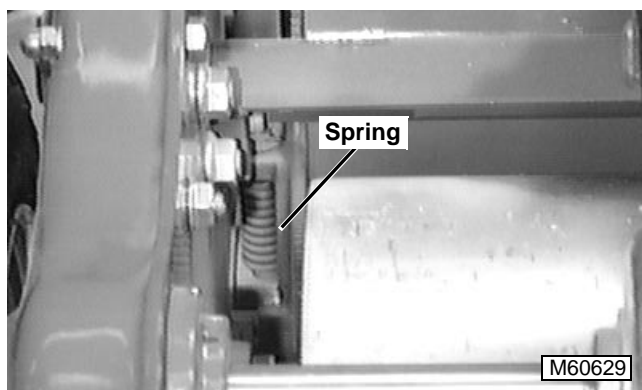

3. Install spring and T-bolt on both sides of mower.

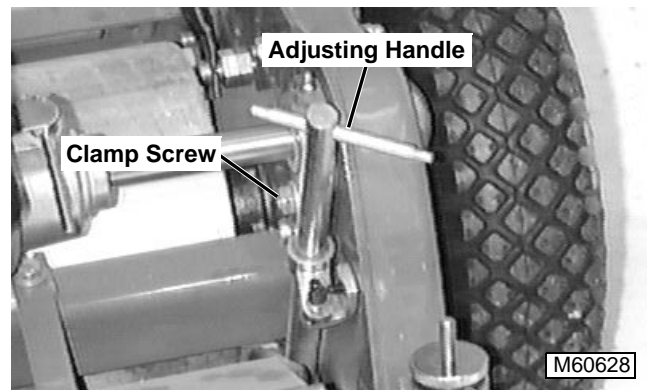

4. Install adjusting handles.
5. Adjust handles until bed knife just clears reel.
6. Tighten clamp screws.

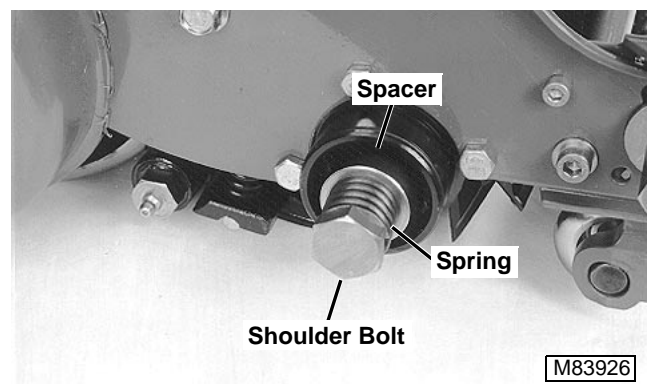

7. Install collar, spring and shoulder bolt.
8. Install cap.

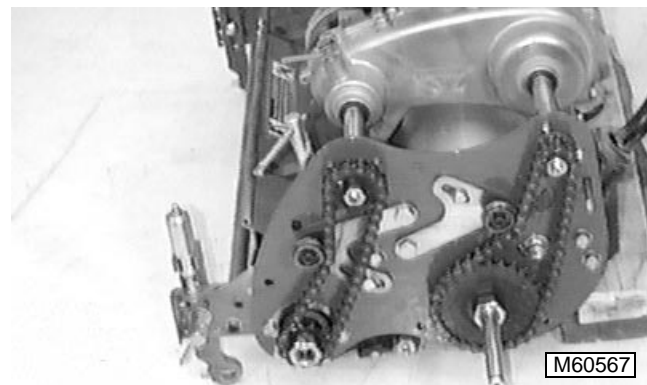

9. Pry right-hand end of reel to left side to check for end play. Reel must slide easily.
10. Lubricate both sides of reel.
11. Adjust reel drive chain tension. (See REEL DRIVE CHAIN TENSION ADJUSTMENT on page 8-17.)
12. Lubricate drive chains. (See GREASE—NORTH AMERICA or GREASE—EUROPE on page 2-13.)

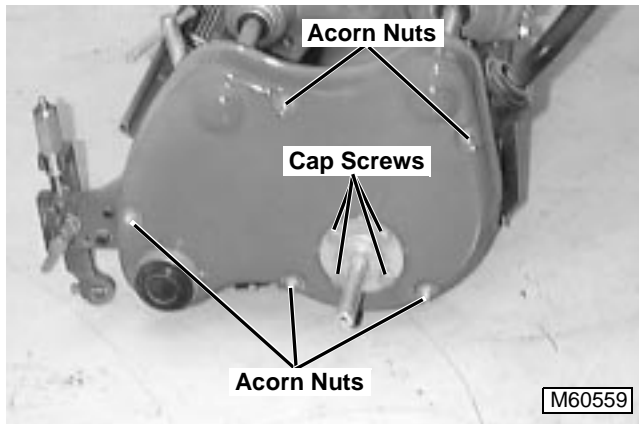

- 13. Install left drive cover.
- 14. Tighten four bearing housing cap screws.

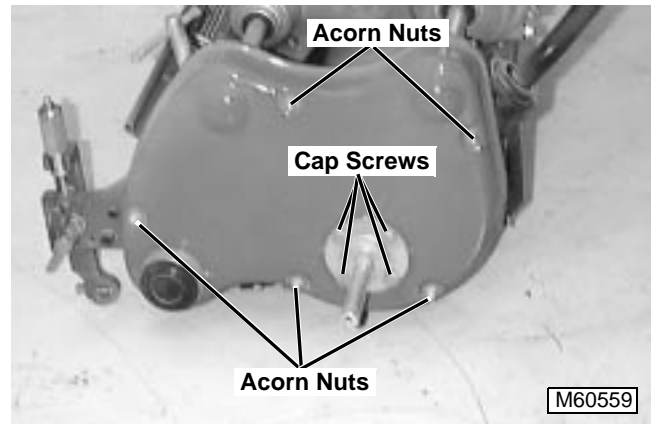

- 2. Loosen four bearing housing cap screws.
- 3. Remove five acorn nuts, washers and shoulder bolts, and remove left drive cover.

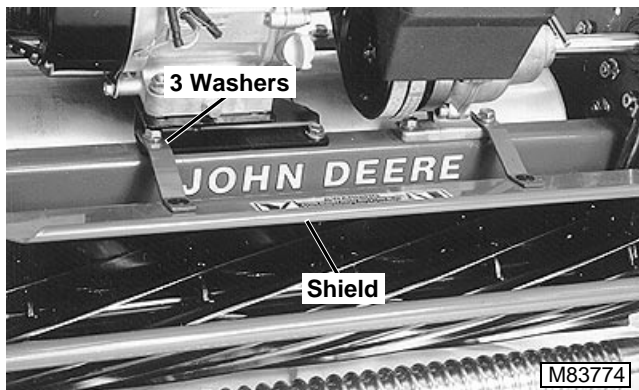

NOTE: Place three washers between shield bracket and engine mount.

- 15. Slide shield under cap screws. Tighten caps screws.
- 16. Adjust bed knife-to-reel clearance. (See BED KNIFE-TO-REEL ADJUSTMENT on page 8-15).
- 17. Backlap reel. (See BACKLAPPING PROCEDURE on page 8-16.)

Removal—With Greens Tender Conditioner (GTC)

- 1. Remove transport wheels and drive collars (if equipped). (See TRANSPORT WHEELS on page 9-3.)

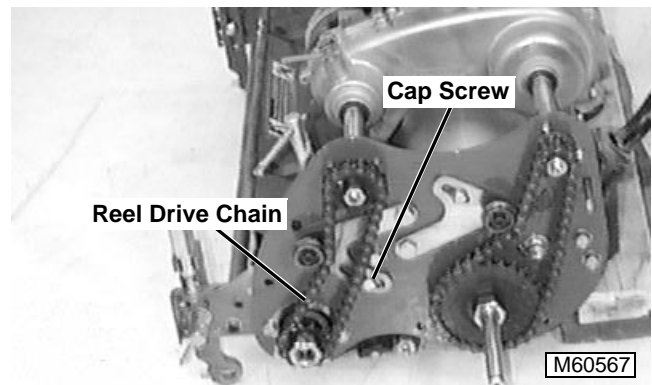

- 4. Loosen cap screw to release chain tension.
- 5. Disconnect master link and remove reel drive chain.

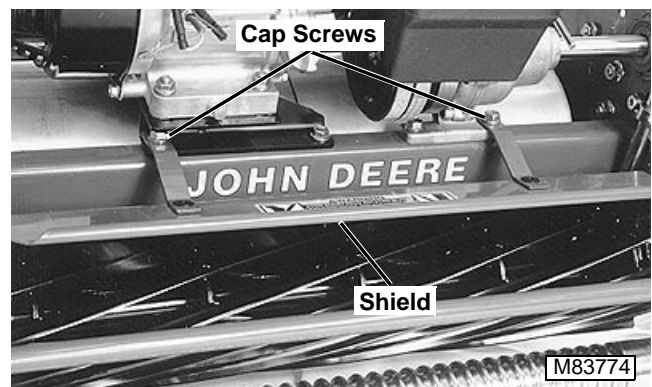

- 6. Loosen cap screws and remove shield.



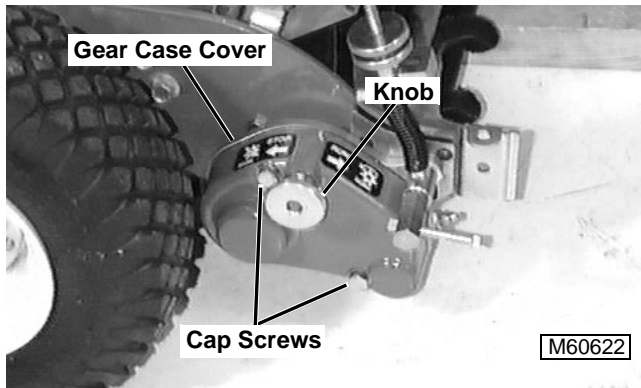

- 7. Turn knob counterclockwise past detent position.
- 8. Remove two cap screws and washers.
- 9. Remove gear case cover.

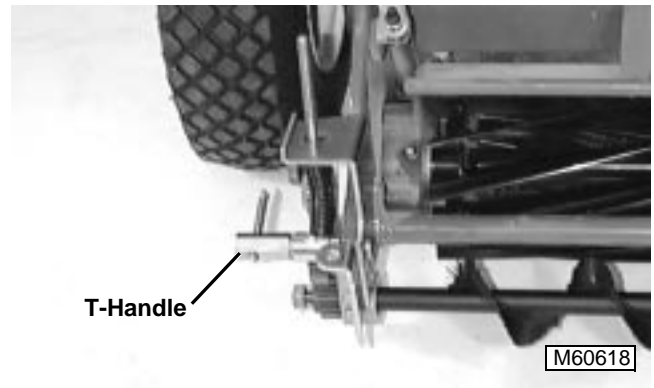

- 12. Remove adjuster T-handle, lock washer and bolt from both sides of mower.

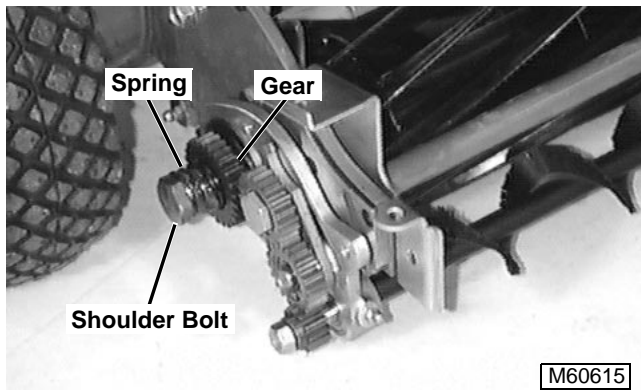

- 10. Remove shoulder bolt, spring and gear.

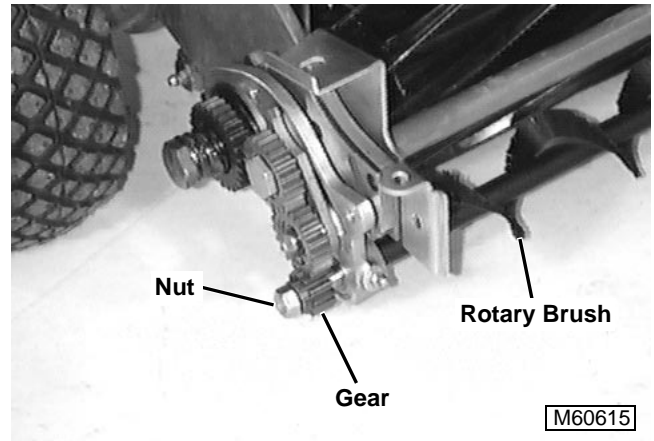

⚠ CAUTION

Always wear protective gloves when working on or near a reel or GTC. Serious personal injury can result from contact with sharp cutting edges.

- 13. Remove nut, gear and key.
- 14. Remove vertical cutter or rotary brush.

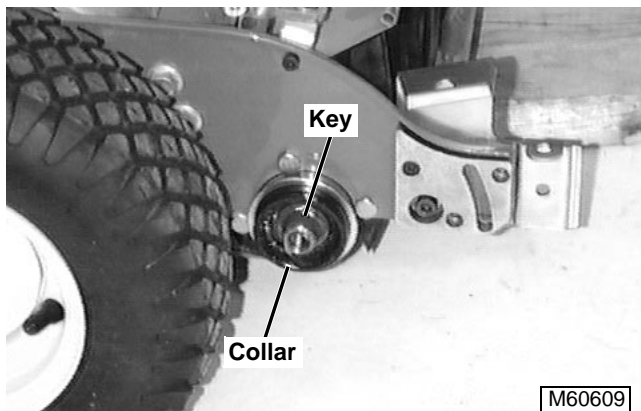

- 11. Remove key and collar.

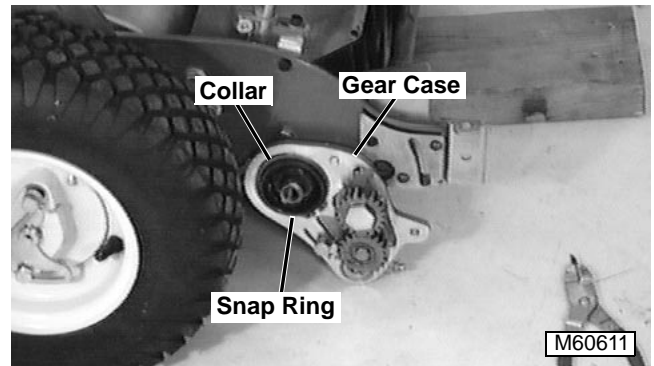

- 15. Remove snap ring, gear case and collar.



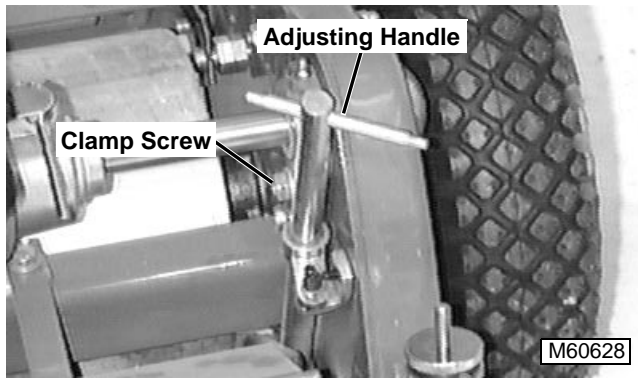

16. Loosen clamp screw and remove bed knife adjusting handles from both sides of mower.

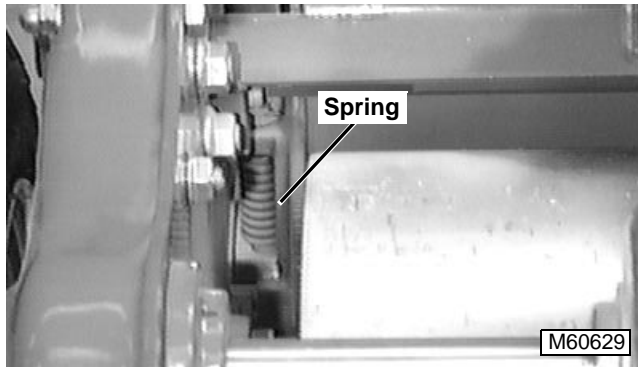

17. Remove spring and T-bolt from both sides of mower.

18. Rotate bed knife support downward.

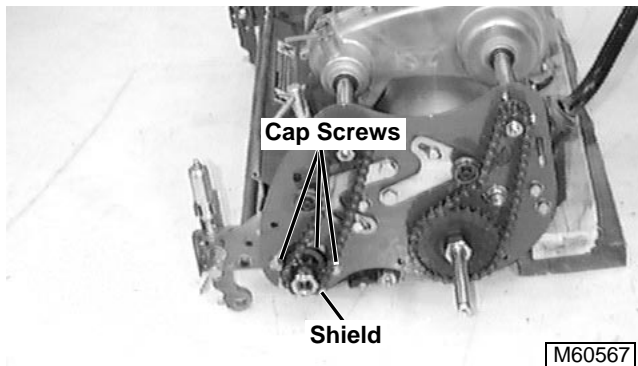

⚠ CAUTION

Always wear protective gloves when working on or near the reel or bed knife. Severe personal injury can result from contact with the sharp cutting edges.

19. Remove three cap screws and shield from left bearing housing. Left end of reel will lower.

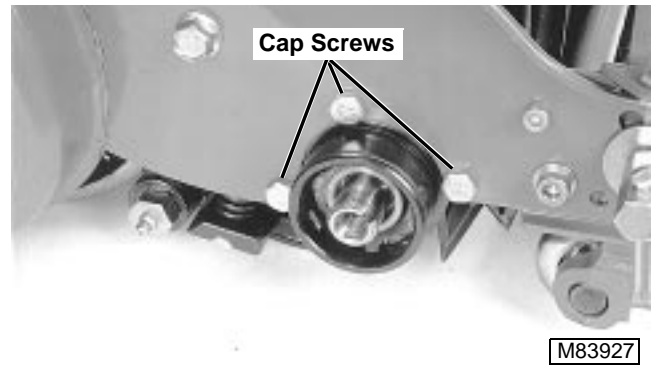

20. Remove three bolts from right bearing housing.

21. Remove reel assembly.

22. Inspect all parts for wear or damage. Replace parts as necessary. (See Disassembly/Inspection/Assembly procedure on page 8-28.)

Installation—With Greens Tender Conditioner (GTC)

⚠ CAUTION

Always wear protective gloves when working on or near a reel or GTC. Serious personal injury can result from contact with sharp cutting edges.

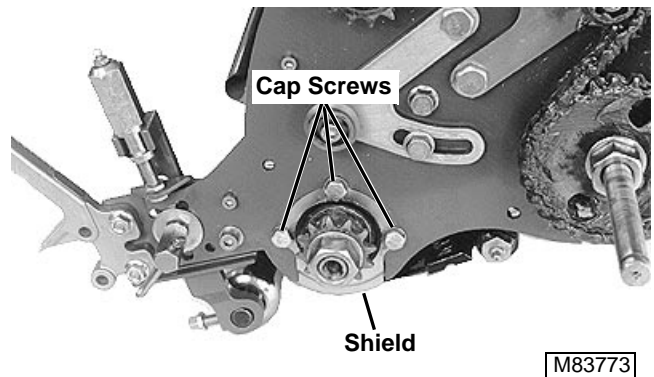

1. Install reel assembly and shield with three cap screws.

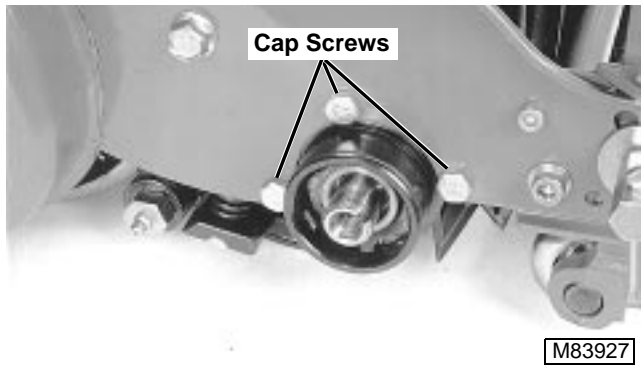

2. Install bearing housing using three cap screws.

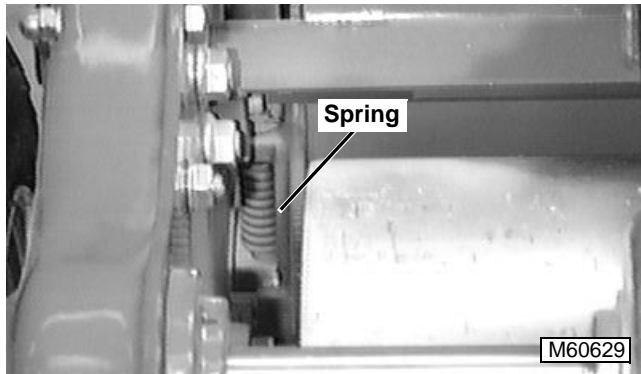

3. Install spring and T-bolt on both sides of mower.

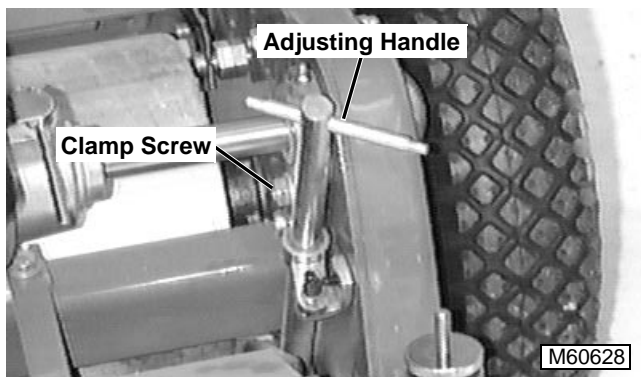

4. Install adjusting handles.
5. Adjust handles until bed knife just clears reel.
6. Tighten clamp screws.

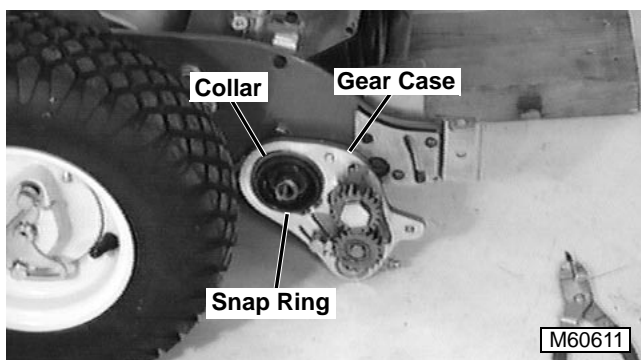

7. Install collar, gear case and snap ring

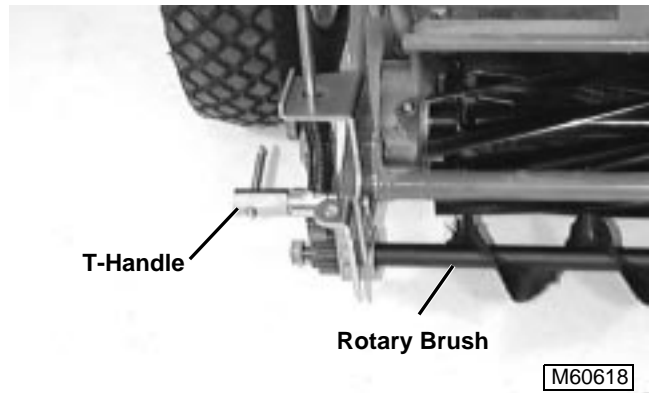

8. Install vertical cutter or rotary brush.
9. Install adjuster T-handle, lockwasher and bolt on both sides of mower.

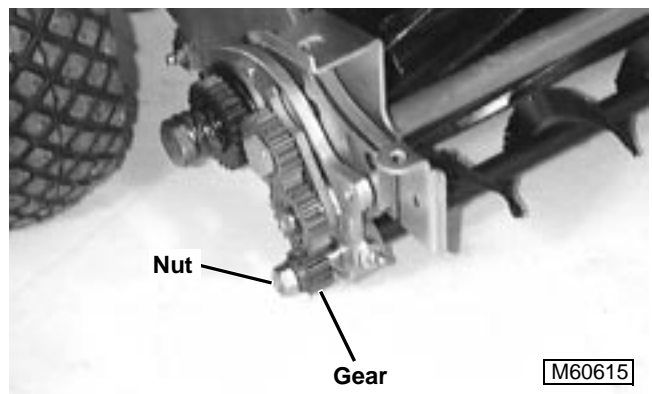

10. Install key and gear and nut.
11. Pry right-hand end of reel to left side to check for end play. Reel must slide easily.
12. Lubricate both sides of reel.

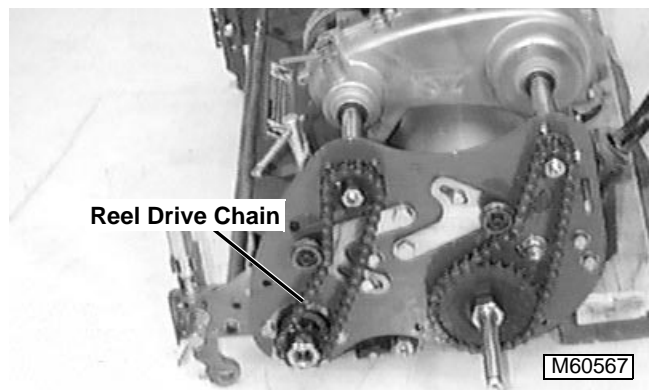

13. Install reel drive chain.
14. Adjust reel drive chain tension. (See REEL DRIVE CHAIN TENSION ADJUSTMENT on page 8-17.)
15. Lubricate drive chains. (See GREASE—NORTH AMERICA or GREASE—EUROPE on page 2-13.)



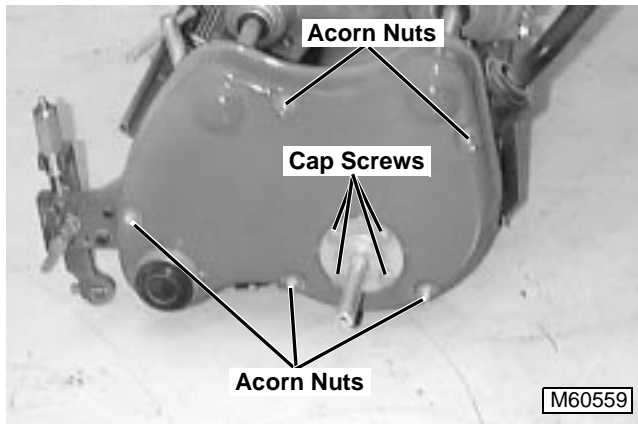

16. Install left drive cover.

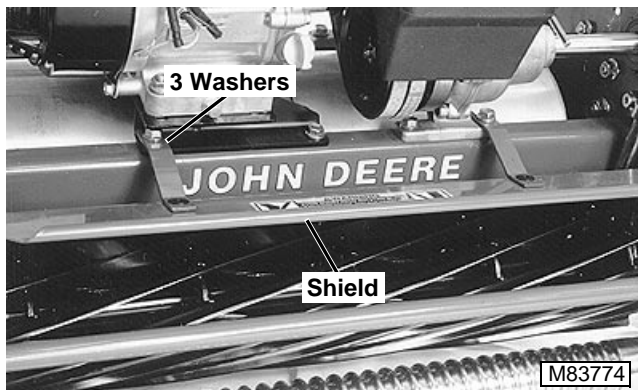

NOTE: Place three washers between shield bracket and engine mount.

17. Slide shield under cap screws. Tighten caps screws.
18. Adjust bed knife-to-reel clearance. (See BED KNIFE-TO-REEL ADJUSTMENT on page 8-15).
19. Backlap reel. (See BACKLAPPING PROCEDURE on page 8-16.)

Bearing Inspection



CAUTION

Always wear protective gloves when working on or near the reel or bed knife. Severe personal injury can result from contact with the sharp cutting edges.

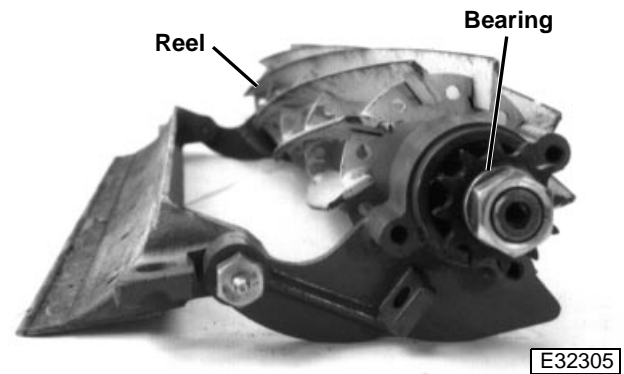

NOTE: If one bearing and seal is being replaced, replace other side also.

Rotate reel and inspect bearing for roughness and ease of rotation. If reel binds or rotates rough, replace bearing and seal. (See Disassembly/Inspection/Assembly procedure on page 8-28.)



Disassembly/Inspection/Assembly

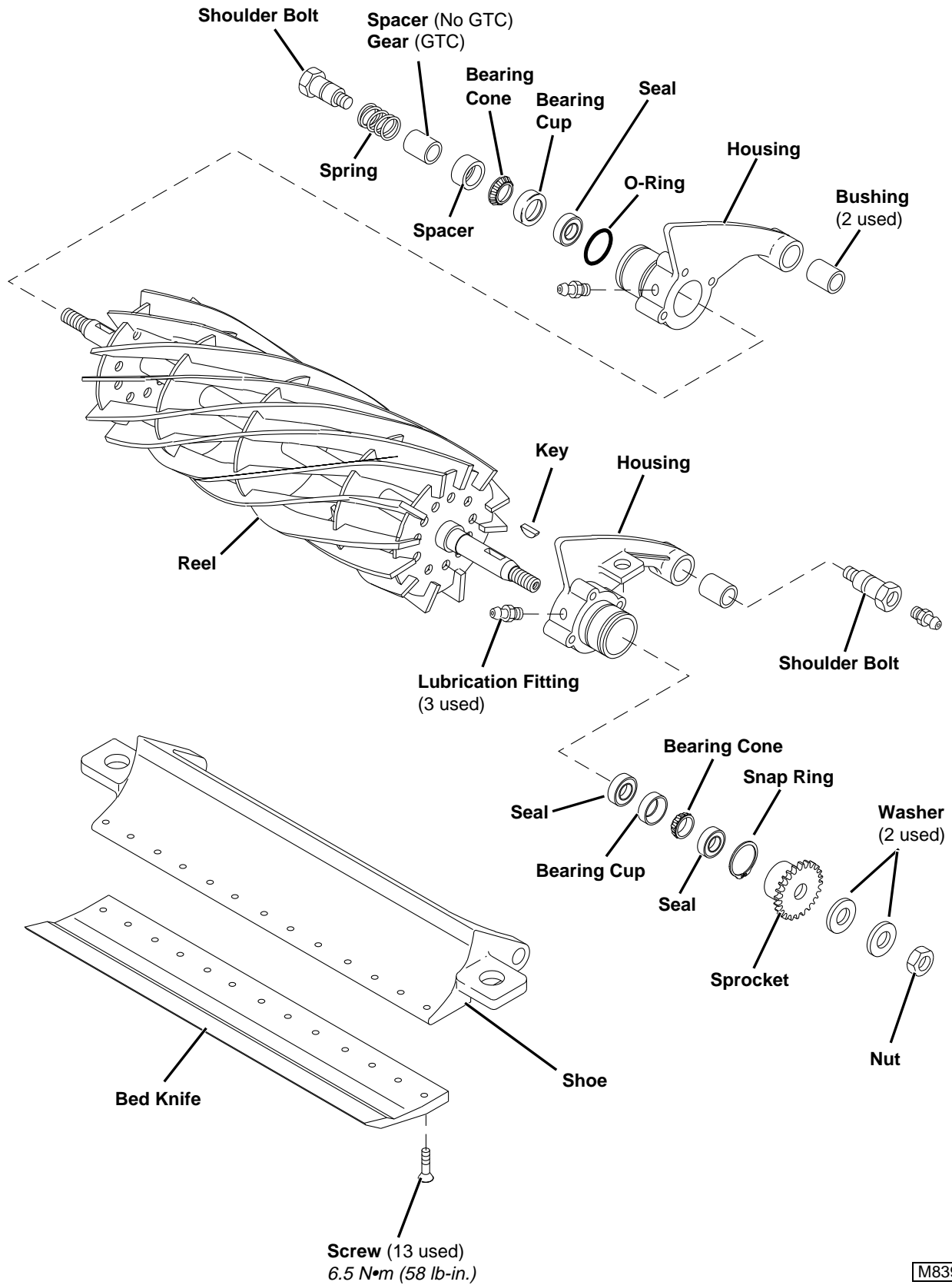

M83940



CAUTION

Always wear protective gloves when working on or near the reel or bed knife. Severe personal injury can result from contact with the sharp cutting edges.

NOTE: If bearings and seal are to be replaced, replace both sides at the same time.

1. Inspect all parts for wear or damage. Replace parts as necessary.
2. Apply reel support grease to lubrication fittings. (See REEL SUPPORT GREASE—NORTH AMERICA or REEL SUPPORT GREASE—EUROPE on page 2-11.)

FRONT ROLLER

Removal/Installation

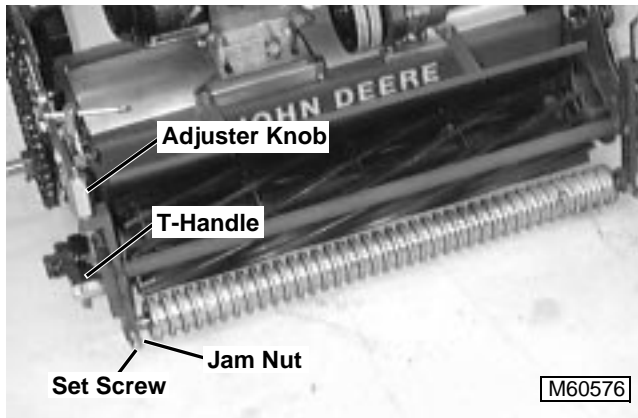

1. Loosen jam nut and set screw at both ends of the roller.
2. Remove T-handle, lock washers, flat washer and round head cap screw at both ends of the roller.
3. Remove roller and brackets.
4. Remove brackets from roller.

Installation is done in the reverse order of removal.

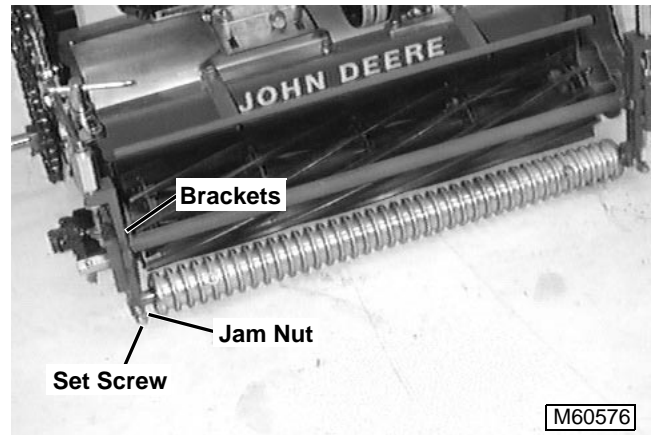

NOTE: DO NOT install set screws into holes in roller shaft.

- Tighten T-handles.
- Center roller between brackets, install set screws and tighten jam nuts.

NOTE: DO NOT over-lubricate. Excess grease could fall from the mower during operation.

- Apply multi-purpose grease to grease fittings.
- Adjust cutting height. (See CUTTING HEIGHT ADJUSTMENT on page 8-17.)



Bearing Replacement

NOTE: This procedure applies to both smooth and grooved rollers, except for AET10558 Grooved Rollers. (See AET10558 GROOVED ROLLER—Bearing Replacement on page 8-30.)

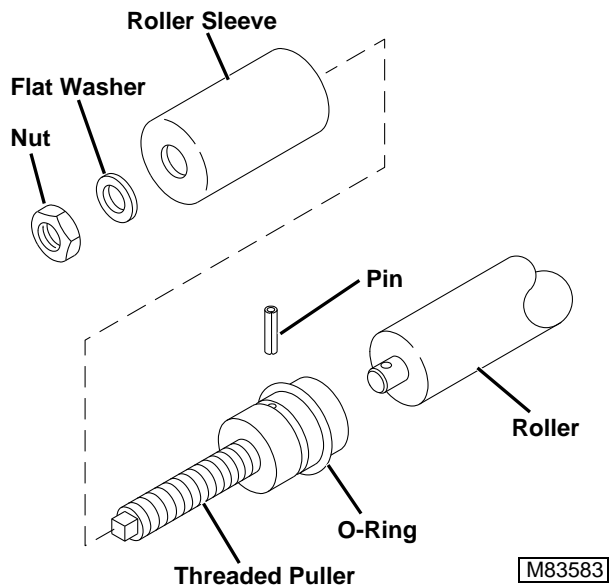

CAUTION

Wear approved eye protection when using JDG795 Roller Bearing Puller.

1. Attach threaded puller to the bearing by inserting the pin through the hole in the bearing shaft and puller. Slide the O-ring over the pin to keep it in position.
2. Slide roller sleeve over the threaded puller with the concave end of the roller sleeve against the end of the roller. Install flat washer and nut on threaded puller.

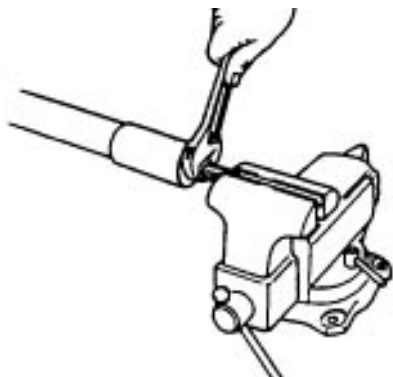

3. Clamp the hex end of the threaded puller in a vice or hold it with a wrench. Turn nut counterclockwise until the bearing is removed from the roller.

IMPORTANT: DO NOT press on center shaft of bearing when installing bearing. Bearings will set and become tight. Bearings must only be installed by pressing on outside race of bearing.

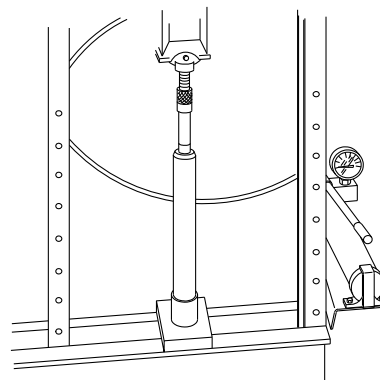

4. Position roller in a press using the roller sleeve to hold the roller while installing the bearing in the other end.
5. Position JD243 or JD506 Bearing Installer over the new bearing in the top end of the roller.

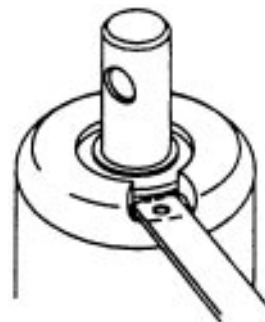

6. **Smooth Rollers:** Place a 0.89-mm (0.035-in.) feeler gauge in the slot where the grease fitting was located. Press the bearing into the roller until the top of the outside bearing race is flush with the top of the feeler gauge. Install the grease fitting.

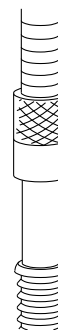

7. **Grooved Rollers:** Press bearing into roller until the top of the outside bearing race is flush with end of the roller.

AET10558 GROOVED ROLLER

Bearing Replacement

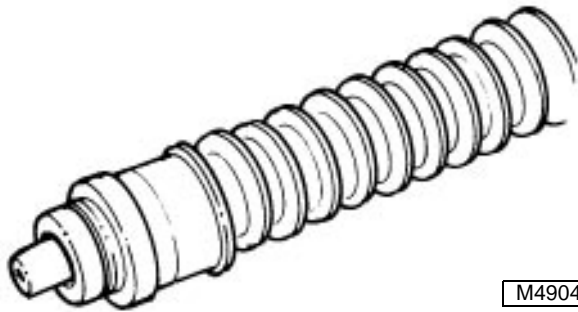

1. Secure roller in a vice. Remove grease fittings.
2. Use a hammer and a block of wood to knock out the opposite end bearing.
3. Remove bearing from shaft and repeat step 2 to knock out the other end bearing.
4. Clean roller end cap and bearing shaft with crocus cloth. Pack bearings with grease.

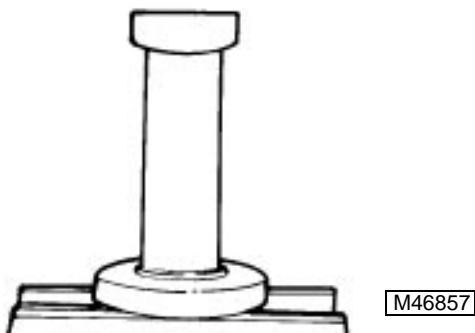

5. Install bearing shaft and bearings (sealed end of bearing towards inside). Apply grease to lip of seal and install with seal lip facing the bearing.
6. Install opposite seal.
7. Install grease fittings and lubricate (Do not over-lubricate, a shot of grease is fine).





This page intentionally left blank.

CONTENTS

Page

MISCELLANEOUS

SPECIFICATIONS

REPAIR SPECIFICATIONS..... 9-2

SERVICE PARTS KITS..... 9-2

REPAIR

TRANSPORT WHEELS 9-3

FRAME AND DRIVE COVERS..... 9-4



SPECIFICATIONS

REPAIR SPECIFICATIONS

Drive Collar Installation dimension (from groove to face of collar) 60 mm (2.40 in.)

SERVICE PARTS KITS

The following kits are available through your parts catalog:

- Transport Wheel and Parking Stand Kit

REPAIR

TRANSPORT WHEELS

Removal/Installation

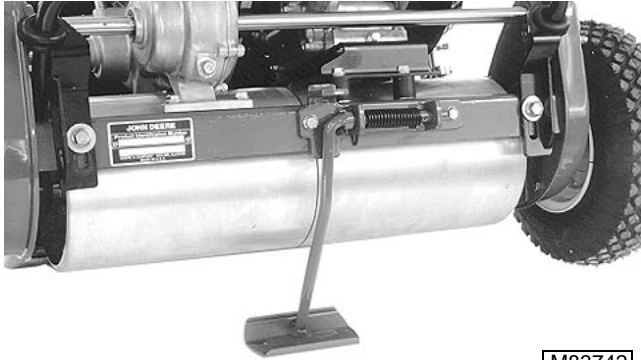

1. Place machine on stand.

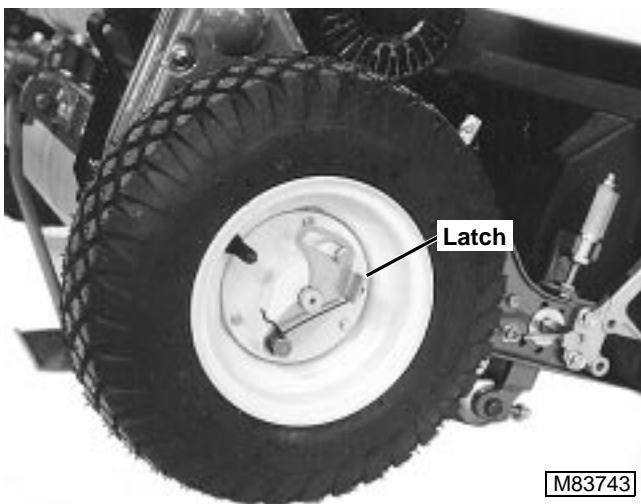

2. Release latch and slide wheel from shaft. Repeat procedure for other side.

NOTE: Remove drive collars only if necessary to perform further service.

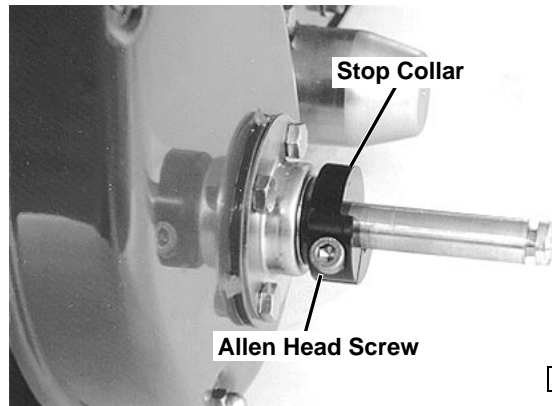

3. Loosen allen head screw, and remove drive collar and key. Repeat procedure for other side.

Installation is done in the reverse order of removal.

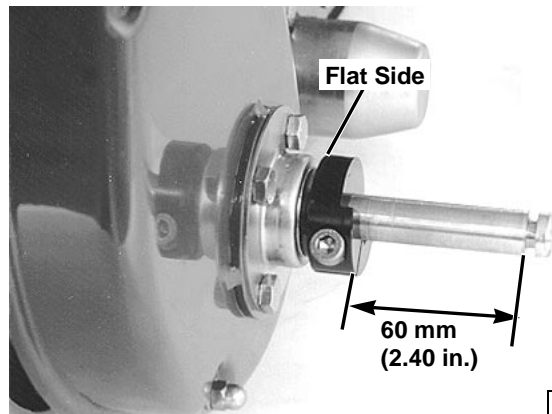

- Install drive collar with flat side facing machine.
- Install drive collar **60 mm (2.40 in.)** from groove on shaft to face of drive collar.



FRAME AND DRIVE COVERS

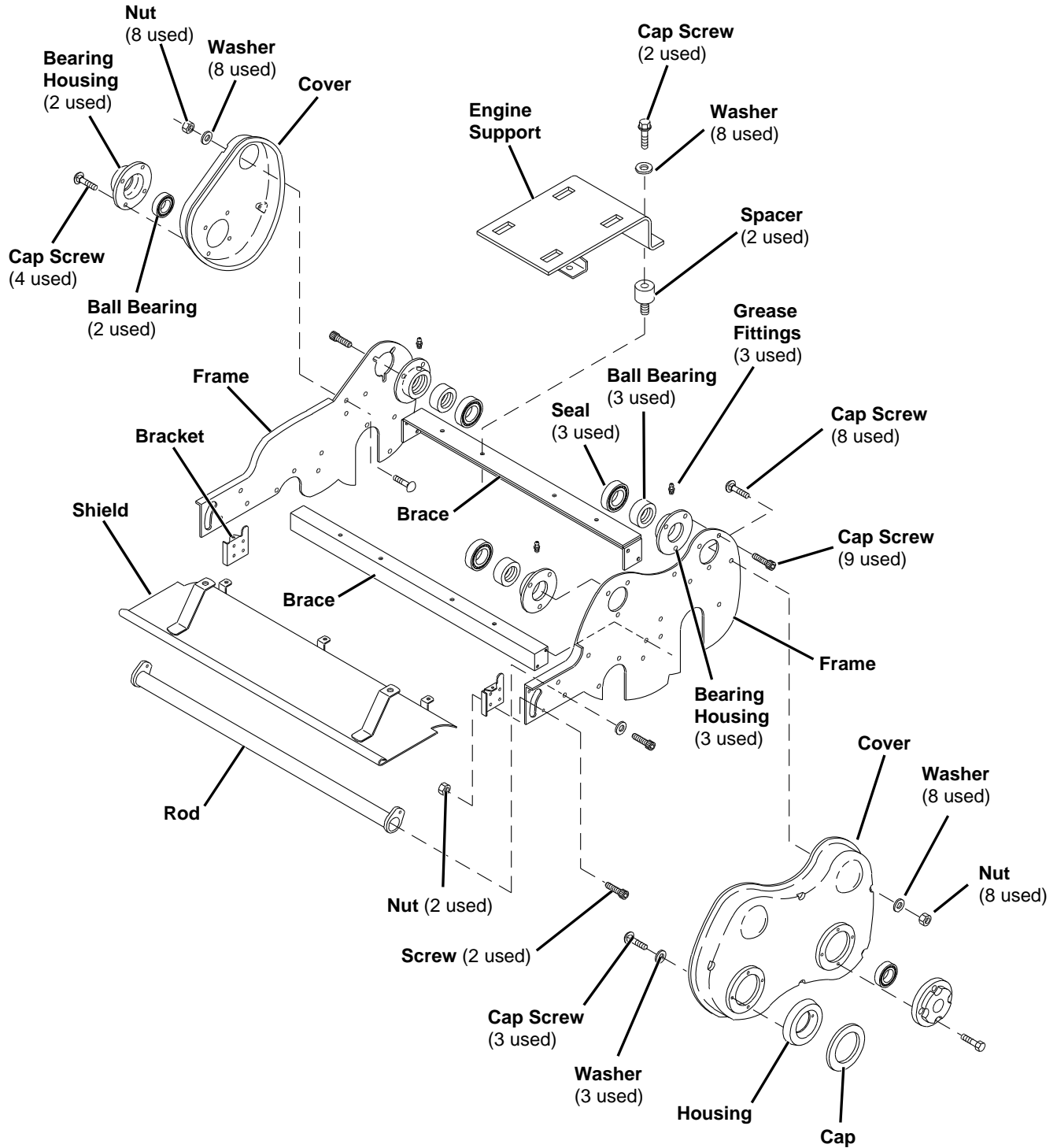

M83924

- Inspect all parts for wear or damage. Replace parts as necessary.
- Apply Non-Clay High-Temperature EP Grease (North America) or Grease-Gard (Europe) to grease fittings.



A

AET10558 Grooved Roller
 Bearing Replacement 8-31
 Air Cleaner
 Removal/Installation 3-30
 Service 3-31
 Alternative Lubricants 2-14
 Anti-Corrosion Grease 2-12

B

Backlapping Information 8-11
 Bed Knife, Removal/Installation 8-20
 Bed Knife-to-Reel Adjustment 8-15
 Blower Housing, Removal/Installation 3-36
 Brake
 Band Replacement 7-9
 Cable Replacement 7-8
 Check and Adjustment 7-7
 Control Lever 6-8
 Brake System
 Diagnosis 7-4
 Operation 7-2
 Troubleshooting Chart 7-3

C

Camshaft and Tappets
 Inspection 3-50
 Removal/Installation 3-49
 Carburetor
 Clean/Inspect/Rebuild 3-35
 Float Level Adjustment 3-36
 Identification Number 2-15
 Pilot Screw and Limiter Cap Replacement
 Removal/Installation 3-32
 Clutch Control 6-7
 Clutch Control Cable 5-14
 Controls, Component Location 6-2
 Cooling System Operation 3-14
 Crankcase Cover
 Bearing Inspection/Replacement 3-49
 Removal/Installation 3-48
 Crankshaft
 Inspection 3-58
 Removal/Installation 3-58
 Timing/Governor Gear Replacement 3-58
 Crankshaft and Connecting Rod
 Analyze Wear 3-59
 Cutting Height Adjustment 8-17

Cutting Unit

Adjustment Specifications 8-3
 Backlapping Information 8-11
 Backlapping Procedure 8-16
 Component Location 8-5
 Dealer Fabricated Tools 8-4
 Diagnosis 8-7
 Frame Alignment Check 8-14
 General Specifications 8-3
 Greens Tender Conditioner Information 8-12
 Height Adjustment 8-17
 Performance Variables 8-13
 Relief Grinding 8-11
 Repair Specifications 8-3
 Troubleshooting Chart 8-6

Cylinder Block

Bearing Inspection/Replacement 3-60
 Deglaze Bore 3-60
 Inspection 3-59
 Oil Seal Replacement 3-60
 Rebore Cylinder 3-60

Cylinder Compression Pressure Test

Cylinder Head and Valves

Analyze Valves 3-45
 Disassembly/Assembly 3-42
 Inspection 3-43
 Lap Valves 3-47
 Recondition Valve Seats 3-46
 Removal/Installation 3-41
 Valve Guide Replacement 3-44

D

Drive Belt

Guide Adjustment 5-11
 Idler Bracket Assembly 5-27
 Replacement 5-14
 Tension Check and Adjustment 5-10

Drive Chain Tensioners

Drive Covers

E

Electrical Schematic

Electrical System

Wire Color Abbreviation Chart 4-2

Engine

External Component Location 3-9
 Internal Component Location 3-11
 Oil Level Check 2-16
 Removal/Installation 3-29
 Repair Specifications 3-3
 Serial Number 2-15
 Service Parts Kits 3-8
 Test and Adjustment Specifications 3-3
 Troubleshooting Chart 3-16
 Troubleshooting Guide 3-18

F

Flywheel, Removal/Installation 3-40
 Frame 9-4
 Front Roller
 Bearing Replacement 8-30
 Removal/Installation 8-29
 Fuel Filter 3-27
 Fuel System
 Troubleshooting Chart 3-16
 Fuel Tank, Removal/Installation 3-27

G

Gasoline Engine Oil
 4-Cycle—Europe 2-9
 4-Cycle—North America 2-8
 Gasoline Specifications
 4-Cycle Engines—Europe 2-7
 4-Cycle Engines—North America 2-6
 Gasoline Storage
 Europe 2-7
 North America 2-6
 Governor
 Adjustment 3-23
 Removal/Installation 3-61
 Grease
 Anti-Corrosion 2-12
 Europe 2-13
 North America 2-13
 Reel Support—Europe 2-11
 Reel Support—North America 2-11
 Greens Tender Conditioner (GTC)
 Adjustment 8-18
 Information 8-12
 Grooved Roller
 Information 8-12

H

Handlebar
 Height Adjustment 6-4
 Removal/Installation 6-5
 Handlebar Cover 6-5

I

Idle Speed Adjustment
 Fast 3-23
 Slow 3-22
 Ignition Coil
 Air Gap Adjustment 3-39
 Removal/Installation 3-39
 Test 3-40
 Inch Fastener Torque Values 2-5

L

Lubricants
 Alternative 2-14
 Mixing 2-14
 Storage 2-14
 Synthetic 2-14
 Lubrication System Operation 3-12

M

Machine Identification Number 2-15
 Metric Fastener Torque Values 2-4
 Muffler, Removal/Installation 3-28

O

Oil
 Speed Reducer—Europe 2-10
 Speed Reducer—North America 2-10
 Oil, 4-Cycle Engine
 Europe 2-9
 North America 2-8
 Operational Checkout Procedures 2-16
 Operator Presence Bail
 Adjustment 6-3
 Repair 6-7
 Operator Presence Bail Check 2-18

P

Park Brake Check 2-18
 Piston and Connecting Rod
 Assembly 3-52
 Connecting Rod Side Play 3-55
 Connecting Rod-to-Crankshaft Clearance 3-55
 Disassembly 3-51
 Inspection 3-53
 Installation 3-51
 Removal 3-50
 Piston Rings
 Analyze Wear 3-55
 Check End Gap 3-55
 Piston, Analyze Wear 3-57
 Power Train
 Adjustment Specifications 5-2
 Component Location and Operation 5-3
 Diagnosis 5-5
 Repair Specifications 5-2
 Troubleshooting Chart 5-4

R

Recoil Starter
 Assembly 3-38
 Disassembly/Inspection 3-37
 Removal/Installation 3-37
 Reduction Assembly
 Bearing/Oil Seal Replacement 3-48
 Removal/Installation 3-47
 Reel and Bed Knife Inspection 8-14
 Reel Assembly
 Bearing Inspection 8-27
 Disassembly/Inspection/Assembly 8-28
 Installation—With GTC 8-25
 Installation—Without GTC 8-22
 Removal—With GTC 8-23
 Removal—Without GTC 8-20
 Reel Clutch Check 2-19
 Reel Support Grease
 Europe 2-11
 North America 2-11
 Reel/Bed Knife Grinding 8-10
 Relief Grinding 8-11
 Rocker Arm Cover, Removal/Installation 3-41
 Rotary Brush Adjustment 8-18

S

Smooth Roller, Information	8-12
Spark Plug Gap Adjustment	3-26
Spark Test	3-25
Speed Reducer	
Assembly	5-20
Disassembly	5-17
Oil Level Check	2-16
Oil—Europe	2-10
Oil—North America	2-10
Removal/Installation	5-15
Synthetic Lubricants	2-14

T

Throttle Cable	
Check and Adjustment	3-22
Removal/Installation	3-28
Throttle Lever	
Check	2-17
Repair	6-8
Tension Adjustment	6-3
Throttle Plate, Removal/Installation	3-32
Torque Values	
Inch Fastener	2-5
Metric Fastener	2-4
Traction Roller	
Adjustment	5-11
Disassembly/Assembly	5-25
Removal/Installation	5-22
Drive Chain Tension Adjustment	5-13
Transport Wheels	9-3
Travel Clutch Check	2-19

V

Valve Clearance Check and Adjustment	3-24
Valves	
Analyze Condition	3-45
Lap	3-47
Vehicle Specifications	2-2

This page intentionally left blank.