

Service Course Manual

AR 250, Fairway 250 & 305

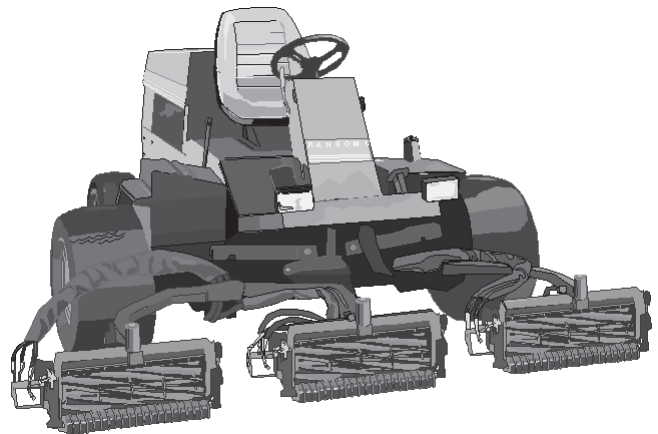

WARNING: If incorrectly used this machine can cause severe injury. Those who use and maintain this machine should be trained in its proper use, warned of its dangers and should read the entire manual before attempting to set up, operate, adjust or service the machine.

INDEX

SPECIFICATIONS

1

CONTROLS

2

HYDRAULICS

3

ELECTRICS

4

NOTES

5

SECTION 1 SPECIFICATIONS

1

AR250 rider rotary

ENGINE SPECIFICATION

Type:	Kubota V1505-BBS-EC-1, 4 cylinder (in line) vertical Diesel engine, 4 stroke, water cooled, 1498cc (91.44 cu.in) with 12V electric start.
Power:	28KW (38HP) @ 3000 ± 50 RPM (no load)
Firing order:	1, 3, 4, 2.
Maximum Speed:	3000 ± 50 RPM (no load)
Idle speed:	1500 +100 -0 RPM
Oil sump capacity:	6 Litres
Oil type:	SAE 10w-30
Fuel Capacity:	45.4 Litres
Fuel type:	No. 2-D Diesel fuel (ASTM D975)

MACHINE SPECIFICATION

DIMENSIONS

Width of cut:	2.5m
Overall length:	3.1m
Overall width:	2.6m
Transport width:	2.13m
Overall height:	1.4m
Overall weight:	1270kg

CAPACITIES

Cooling system:	4 Litres , 50/50 water antifreeze mix
Hydraulic oil Tank:	37.8 Litres
Hydraulic oil Type:	SAE 10W-30.

WHEELS & TYRES

Front tyres:	26.5 x 14.00 - 12 4 ply rating turf tread
Rear tyres:	20 x 10.00 - 8 4 ply rating turf tread
Speeds (cutting fwd):	0 - 12 km/hr (0 - 7.5 mph)
Speeds (cutting rev):	0 - 6.4 km/hr (0 - 4 mph)
Speeds (Transport fwd):	0 - 16 km/hr (0 - 8.5 mph)
Tyre pressure:	1 kg/cm ² (14 psi) (all tyres)

CUTTING SPECIFICATIONS

Construction:	Heavy duty welded pressed steel
Cutter decks:	Five 559mm (22") rotary mulching decks supported by equal ratio lift arms.
Cutting blades:	Patent pending twin blades. Lower blade 559mm (22"), upper blade 546mm (21.5").
Height of cut:	19mm to 133mm (3/4" to 5 1/4") Adjustable in 6mm (0.25") increments, no tool required.
Cutting performance:	2.3ha/hr @ 12km/h (5.6 acres/hr @ 7.5 mph)
Rear roller:	102mm (4") diameter smooth roller.

HYDRAULIC DETAIL

TRANSMISSION

- Pump: Sauer Sundstrand MPV035D 35cc, 102 litres per minute @ 3000rpm.
Main relief valves 2500psi.
- Boost (Charge) Pump: Part of main transmission pump, relief valve 200psi
- Front wheel motors: Parker ME29 - ME29219AAAF 29.1 cu in/rev
Rear wheel motors: Parker ME21 - ME210208AAJC 20.6 cu in/rev

CUTTING

- Pump: Casappa 50 litres per minute @ 3000rpm
Relief Valve: 3000psi located on deck control valve
- Motors: Casappa PLM20 16L0-A307-L0 1.01 cu in/rev, spindle speed 3000rpm
blade tip speed 17000 ft/min approx.
Integral relief valve 1015psi each motor.

STEERING AND LIFT

- Pump: Casappa 19.15 litres per minute @ 3000rpm
- Steering Valve: Ross 5 port priority
- Lift Valve: Dukes/danfoss
- Relief valve: Steering and lift relief valve test port located on the aluminium junction block under the 4WD valve, 1200psi relief.

Fairway 250 & 305

ENGINE SPECIFICATION

Fairway 305

Type:	Kubota V1505-BBS-EC-1, 4 cylinder (in line) vertical Diesel engine, 4 stroke, water cooled, 1498cc (91.44 cu.in) with 12V electric start.
Power:	28KW (38HP) @ 3000 ± 50 RPM (no load)
Firing order:	1, 3, 4, 2.
Maximum Speed:	3000 ± 50 RPM (no load)
Idle speed:	1500 +100 -0 RPM
Oil sump capacity:	6 Litres
Oil type:	SAE 10w-30
Fuel Capacity:	45.4 Litres
Fuel type:	No. 2-D Diesel fuel (ASTM D975)

Fairway 250

Type:	Kubota V1305-BBS-EC-1, 4 cylinder (in line) vertical Diesel engine, 4 stroke, water cooled, 1335cc (81.47 cu.in) with 12V electric start.
Power:	25KW (33HP) @ 3000 ± 50 RPM (no load)
Firing order:	1, 3, 4, 2.
Maximum Speed:	3000 ± 50 RPM (no load)
Idle speed:	1500 +100 -0 RPM
Oil sump capacity:	6 Litres
Oil type:	SAE 10w-30
Fuel Capacity:	45.4 Litres
Fuel type:	No. 2-D Diesel fuel (ASTM D975)

MACHINE SPECIFICATION

DIMENSIONS (Fairway 250)

Width of cut:	2.94 (2.49)
Overall length:	2.88m (2.91)
Overall width:	2.52m (2.13)
Overall height:	1.6m (1.6)
Overall weight:	1515Kg (1270)

CAPACITIES

Cooling system:	5 Litres , 50/50 water antifreeze mix
Hydraulic oil Tank:	37.8 Litres
Hydraulic oil Type:	SAE 10W-30.

WHEELS & TYRES

Front tyres:	26.5 x 14.00 - 12 4 ply rating turf tread
Rear tyres:	20 x 10.00 - 8 4 ply rating turf tread
Speeds (cutting fwd):	0 - 12 km/hr (0 - 7.5 mph)
Speeds (cutting rev):	0 - 6.4 km/hr (0 - 4 mph)
Speeds (Transport fwd):	0 - 16 km/hr (0 - 8.5 mph)
Tyre pressure:	1 kg/cm ² (14 psi) (all tyres)

SECTION 2 CONTROLS

STARTER KEY SWITCH

The starter key (A) should be turned clockwise to the 'pre-heat' (No. 2) position to heat the glowplugs when the green warning lamp goes out, on warning lamp display module, turn the starter key clockwise to the 'start' (No. 3) position to start the engine. After starting, the key should be released and allowed to return automatically to the 'on' (No. 1) position for normal running.

THROTTLE CONTROL LEVER

The lever (B) should be moved away from the operator to increase the engine speed



2

STEERING WHEEL RAKE ADJUSTMENT

The steering wheel is adjustable for rake. The clamping release knob (A) is situated on the side of the control console on the left hand side. To adjust turn the clamping knob anticlockwise to release and pivot the steering wheel backwards and forwards to obtain desired setting then lock in position by turning clamping knob clockwise.



TRACTION FOOT PEDAL

To move the machine forward press the front of the foot pedal (A). To reverse depress the rear of the foot pedal. When the pedal is released it will return to its

NEUTRAL LATCH (B)

Has two functions:

1. The engine cannot be started when the Neutral Latch is depressed.
2. The FWD/REV pedal will not work as described if the Neutral Latch is

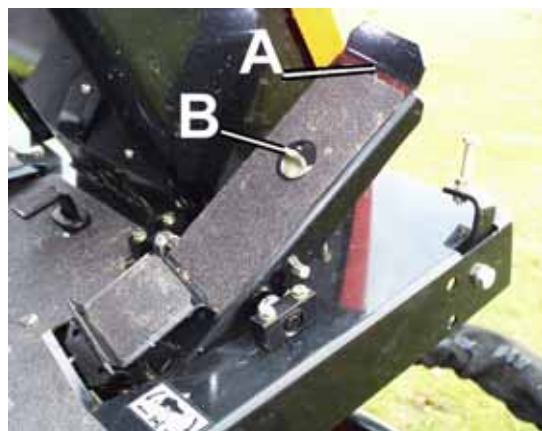

SPEED LIMITER

The speed limiter (A) is operated by pivoting the lever under the footpedal. When positioned under the footpedal the machine is limited to cutting speed, when



PARK BRAKES

Push the pedal forward (A) until it locks to set parking brake. Release parking brake by pushing the brake pedal at the same

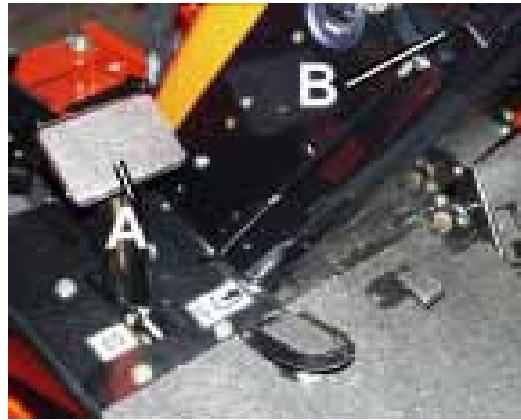

HYDRAULIC LIFT LEVER

The cutting units can be raised and lowered by control lever (A) situated on the right hand side of the operators seat and can be operated as follows:

To lift: Move the lever backwards and hold in position until the units are at the required height.

To lower: Move the lever forwards and hold in this position, the units will lower to ground level. The lever automatically returns to a neutral position when released.

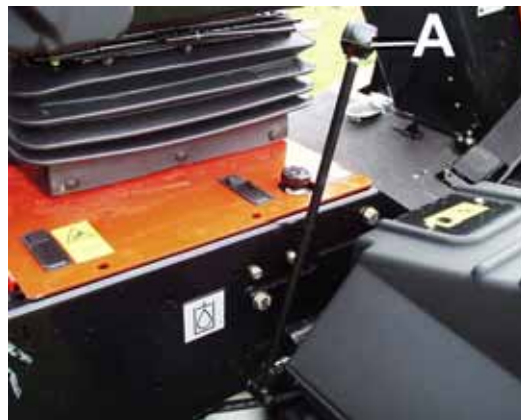

NOTE: If any unit is raised out of work then lowered into work again the blades

UNIT COUNTERBALANCE CONTROL

Cutting unit ground pressure can be varied within preset limits and is controlled by the handwheel (A) on the right hand side of the operator's seat located next to the lift/lower lever. The handwheel is turned clockwise to reduce the groundweight of the cutting unit, improving slope climbing ability.

The handwheel is turned anti clockwise to increase the ground weight of the unit. Increased down pressure will reduce the likelihood of cutting unit bounce when cutting undulating ground. When cutting level ground the normal setting is midway way between the maximum and minimum positions.

VARIABLE CYLINDER SPEED

The speed of rotation of the cutting cylinders is adjustable by means of the handwheel (A) situated on the left hand side of the operator. Cylinder speed should be set to maximum in normal cutting conditions. In very long growth conditions, cylinder speed should be reduced to obtain best finish, cylinder speed should also be reduced when cutting very short, dry grass to prevent excessive cylinder and bottom blade wear. Rotate the hand wheel clockwise to increase cylinder speed, anticlockwise to decrease cylinder speed.

BACKLAPPING LEVER

Sets reel rotational direction with three positions:

(a) forward for mowing, (b) reverse for backlapping and (c) neutral. See the separate cutting unit operator's manual for an explanation of the backlapping procedure.



2



6.12 CUTTING UNIT SWITCHES

To commence cutting ensure speed limiter is in mow position and the units have been lowered. Push bottom of the rocker switch (G) and depress foot switch (A) Push top of rocker switch to stop

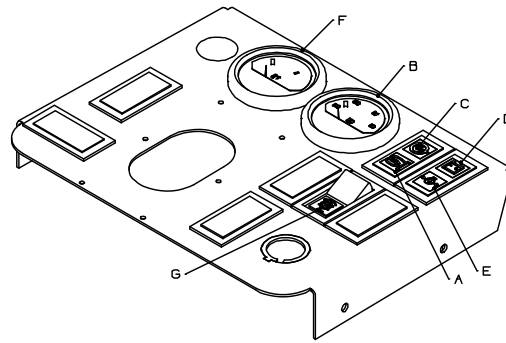

6.13 UNIT TRANSPORT STOP

Depressing the pedal (A) while lifting the cutting units allows the cutting units to be

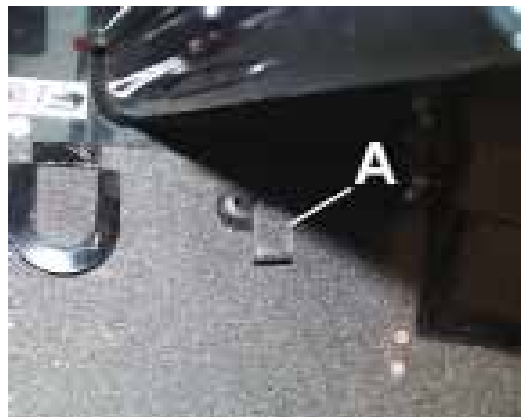

INSTRUMENT PANEL

A. ENGINE PREHEAT INDICATOR LAMP

Colour green, on when the ignition switch is turned clockwise to the pre-heat position. Once the lamp goes out the engine can be started.

B. ENGINE TEMPERATURE GAUGE

Indicates current temperature of engine, whilst running.

C. HYDRAULIC OIL WARNING LAMP

Colour red, on when the hydraulic oil temperature reaches a preset level. If the lamp comes on bring the machine to a stop, disengage the cutting units, apply the parking brake and stop the engine.

D. CHARGING WARNING LAMP

Colour red, on when ignition is switched on and will go out when the engine is started. If the light comes on while the engine is running, the fan belt may be slipping or broken or a fault in the electrical system is indicated and should be investigated. **STOP IMMEDIATELY.**

E. ENGINE OIL PRESSURE WARNING LAMP

Colour red, on when the ignition is switched on, and will go out once the engine has started. If the light comes on while the engine is running - **STOP IMMEDIATELY** as this indicates that the engine oil pressure is too low. Check the level of oil in the sump and top up as necessary. Check the oil pressure sender switch. Continued operation may cause extensive damage to the engine.

F. FUEL GAUGE

Located to the left of the engine temperature gauge. Monitors fuel level.

HOURLY METER

Located on the lefthand side of the steering tower, above the parking brake. (A) Records engine running hours.

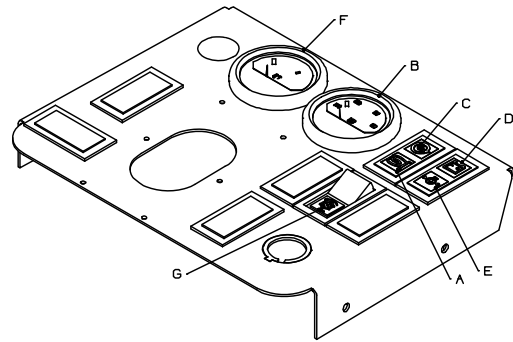

REEL STOP LEVER

Friction control that keeps cutting unit from bouncing when operating over rough



BONNET RELEASE KEY

Release bonnet by inserting key (A) into

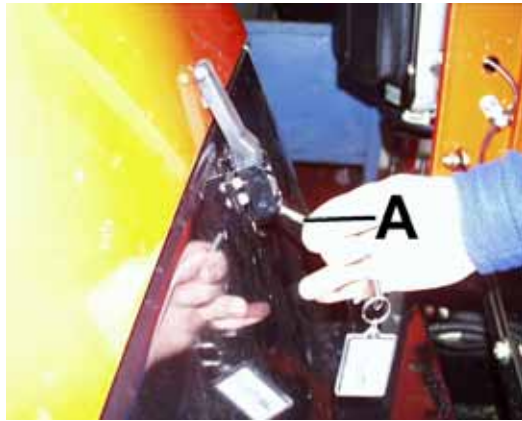

AR 250 Adjustments

HEIGHT OF CUT

The height of cut can be set between: 3/4" (19mm) - 5 1/4" (133mm) in 1/4" (6mm) increments.

1. Examine the decals on the cutter deck to determine which pin position is correct for the height of cut desired.(A)

2. If changing the height of cut from the existing position:

a.Remove the cotter pin and washer securing the two height of cut pins (B) at one side of the deck.

b.Grasp a handle on the top of the deck (C) and simultaneously remove the height of cut pins.

c.While still holding the handle, guide the deck so that the height of cut pins can be reinserted into the desired positions.

d.resecure the height of cut pins with the cotter pins and washers.

3 repeat with the height of cut pins on the other side of the deck.

4. repeat steps 2 and 3 for all other cutter decks, setting the same height

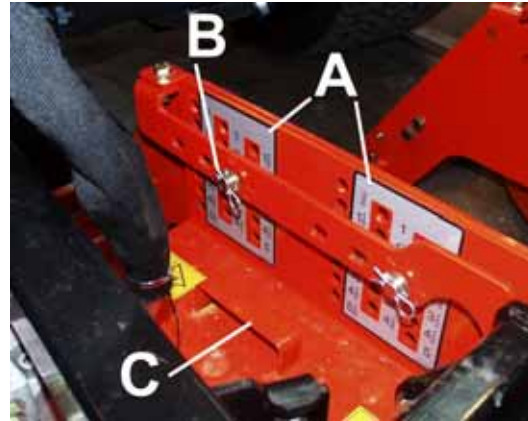

Fairway / T - Plex Cutting Unit

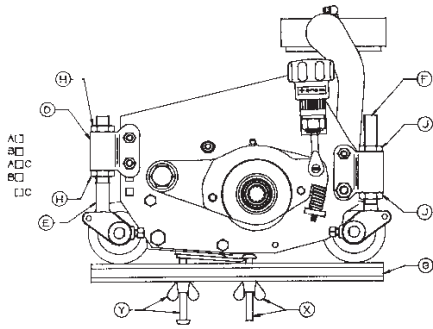

Fig.2

ADJUSTMENTS

Read Safety Instructions

HEIGHT OF CUT (FIG.2)

It is important to set the rear roll parallel to the bottom blade (bedknife) in order to achieve the minimum height of cut setting for the three ranges of height, in the three sets of mounting housing (D) bolt holes. Positions 'A', 'B' & 'C'. Setting the minimum height with the mounting housings (D) in position 'A' will allow minimum height and parallelism to be achieved in each of the other two positions 'B' & 'C'.

Once the range has been chosen the actual height of cut is set by adjusting the front roll only by carriage screws (F) and locknuts (J).

Height of cut range	minimum height of cut	maximum height of cut
---------------------	-----------------------	-----------------------

Holes 'A'	6.0mm(1/4in)	
	23.0mm(29/32in)	

Holes 'B'	13.8mm(9/16in)	
-----------	----------------	--

	30.0mm(1 3/16in)	
--	------------------	--

Holes 'C'	21.7mm(27/32in)	38.0mm(1 1/2in)
-----------	-----------------	-----------------

TO SET REAR ROLL

with a new bottom blade (bedknife)

1. Set the height of cut setting bar (G) as follows:

a. Screw X to 6mm(1/4in) under the head.

b. Screw Y to 5.2mm (7/32in) to screw thread tip.

Note: The difference between screw X and screw Y is 0.8mm (1/32in).

2. Set roll carriage mounting housing(D) bolts into holes 'A'.

3. Place the setting bar (G) as shown at one end of the bottom blade with the

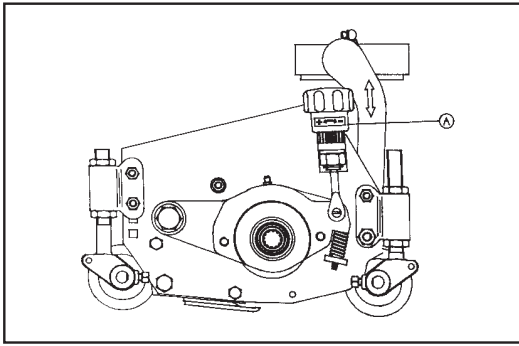

Fig. 3

CUTTING CYLINDER TO BOTTOM BLADE ADJUSTMENT (FIG.3)

To check that the cutting cylinder is set to the bottom blade correctly, hold a piece of thin paper between the edge of the blade and the spiral cutters and turn the cylinder manually.

The paper should be cut cleanly along the total length of the bottom blade, if not, some adjustment may be necessary, BUT DO NOT OVERTIGHTEN. Alternatively if the cylinder is worn it may require back lapping before adjusting.

To adjust:

1. To adjust the cylinder to the bottom blade lift and turn alternately left and right hand handwheels (A Fig.3). (clockwise to put on cut anticlockwise to take off cut) and release, keep turning the handwheel until it locates in the serrated locking ring. The adjuster is of the notched type and each notch is moving the cylinder in increments of approximately 0.04mm (0.0015in).

THIS IS A SELF LOCKING MECHANISM THERE BEING NO NECESSITY TO UNLOCK OR LOCK THE MECHANISM.

IMPORTANT: IN ROUGH GROUND CONDITIONS IT MAY BE NECESSARY TO LOCK THE NUTS SECURING THE BEARING HOUSINGS TO THE SIDE FRAME WHERE THEY RUN IN ADJUSTING SLOTS TO RETAIN CYLINDER TO BOTTOM BLADE

SECTION 3 HYDRAULICS

AR 250

1 - Lift and Cutting Circuit

Fairway 250 & 305

1 - Lift and Steer Circuit

2 - Cutting Circuit

3 - Backlapping Circuit

All Machines

1 - Transmission Circuit

AR250

Lift, steering and cutting circuits

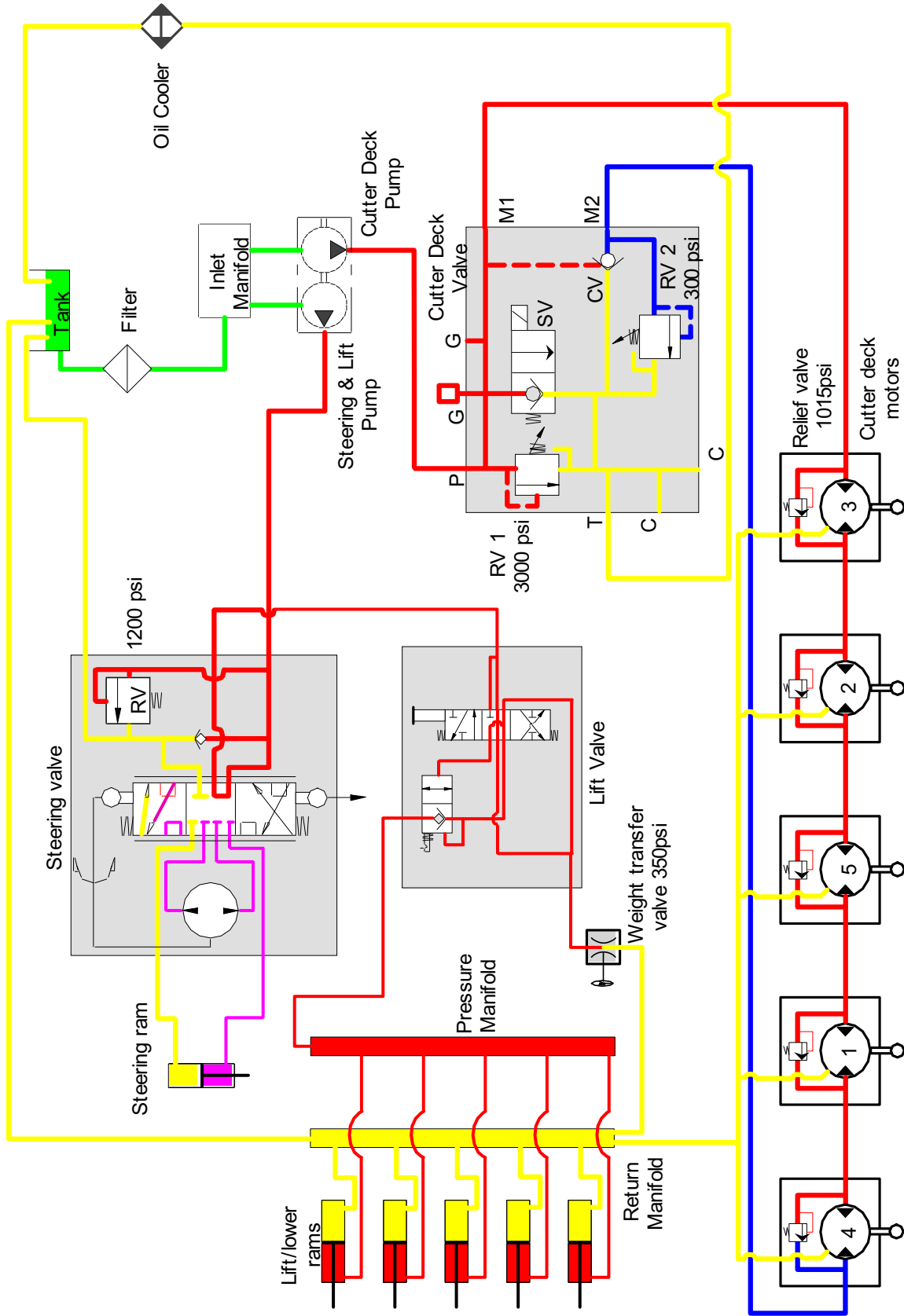

Fairway 250 & 305 Lift & steering circuits

FAIRWAY 250 & 305 STEERING & LIFT CIRCUIT

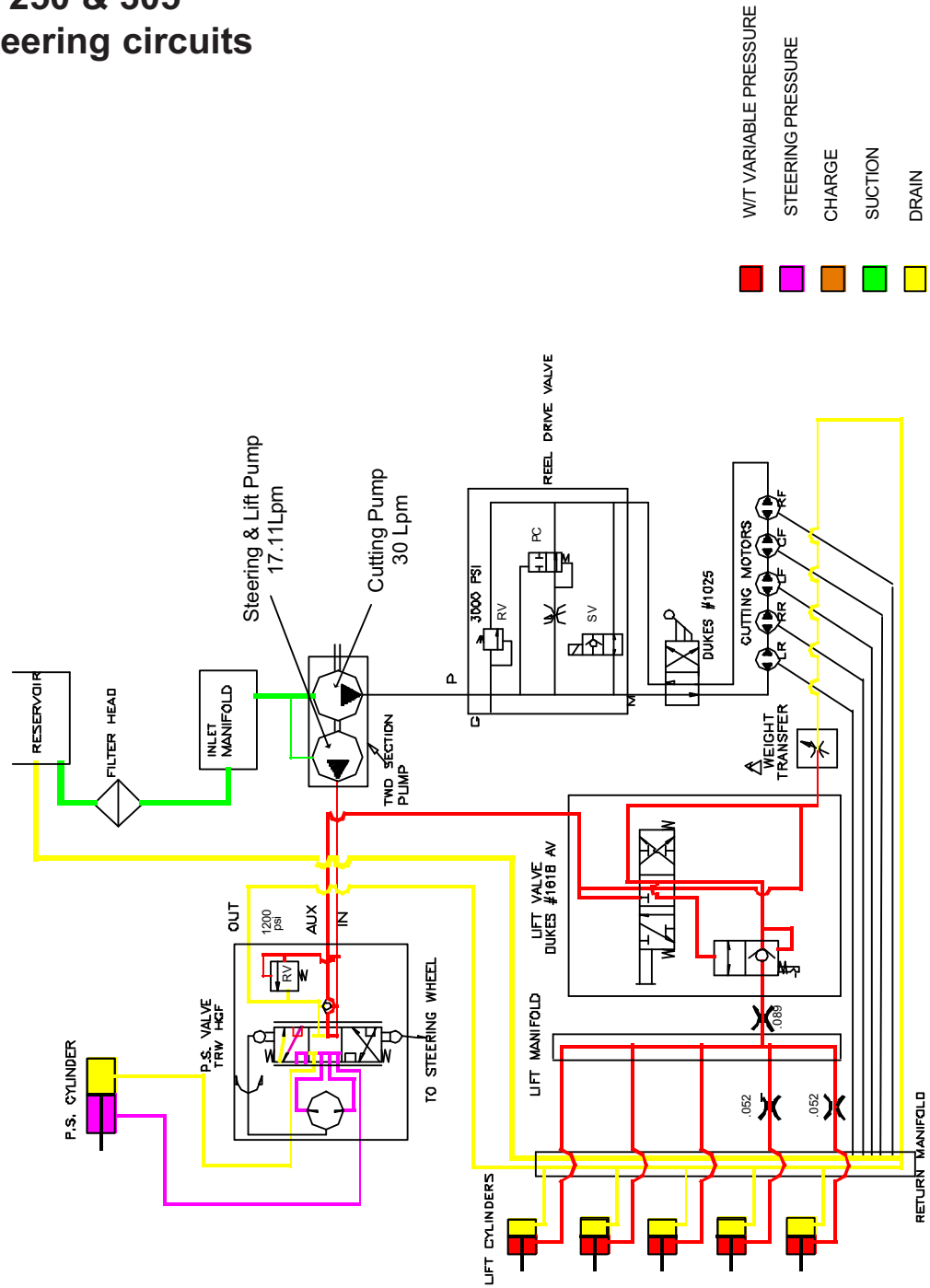

Fairway 250 & 305 Cutting circuit - (forward drive)

- PRESSURE
- RETURN
- VARIABLE FLOW
- SUCTION
- DRAIN

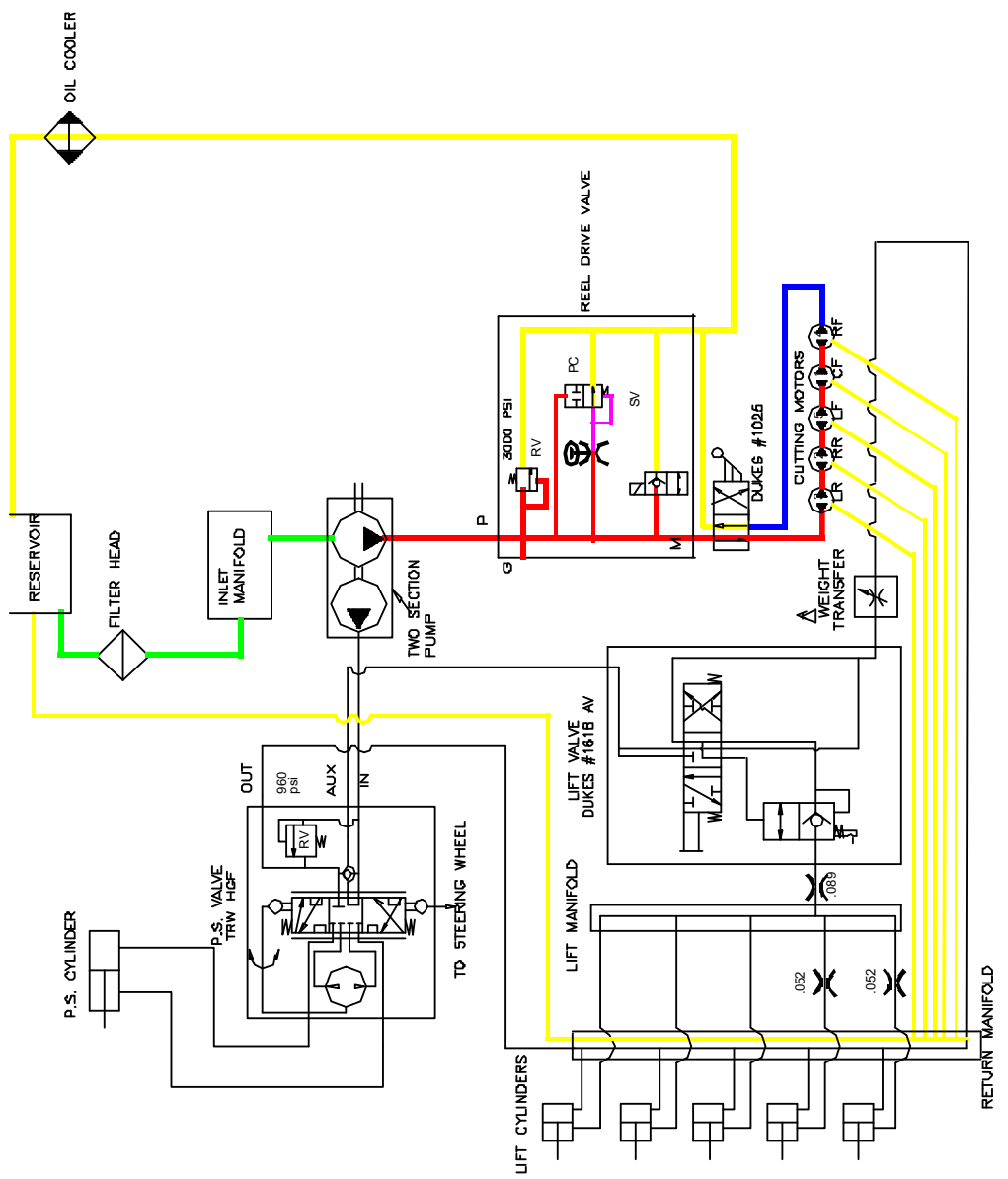

Fairway 250 & 305

Cutting circuit - (backlapping)

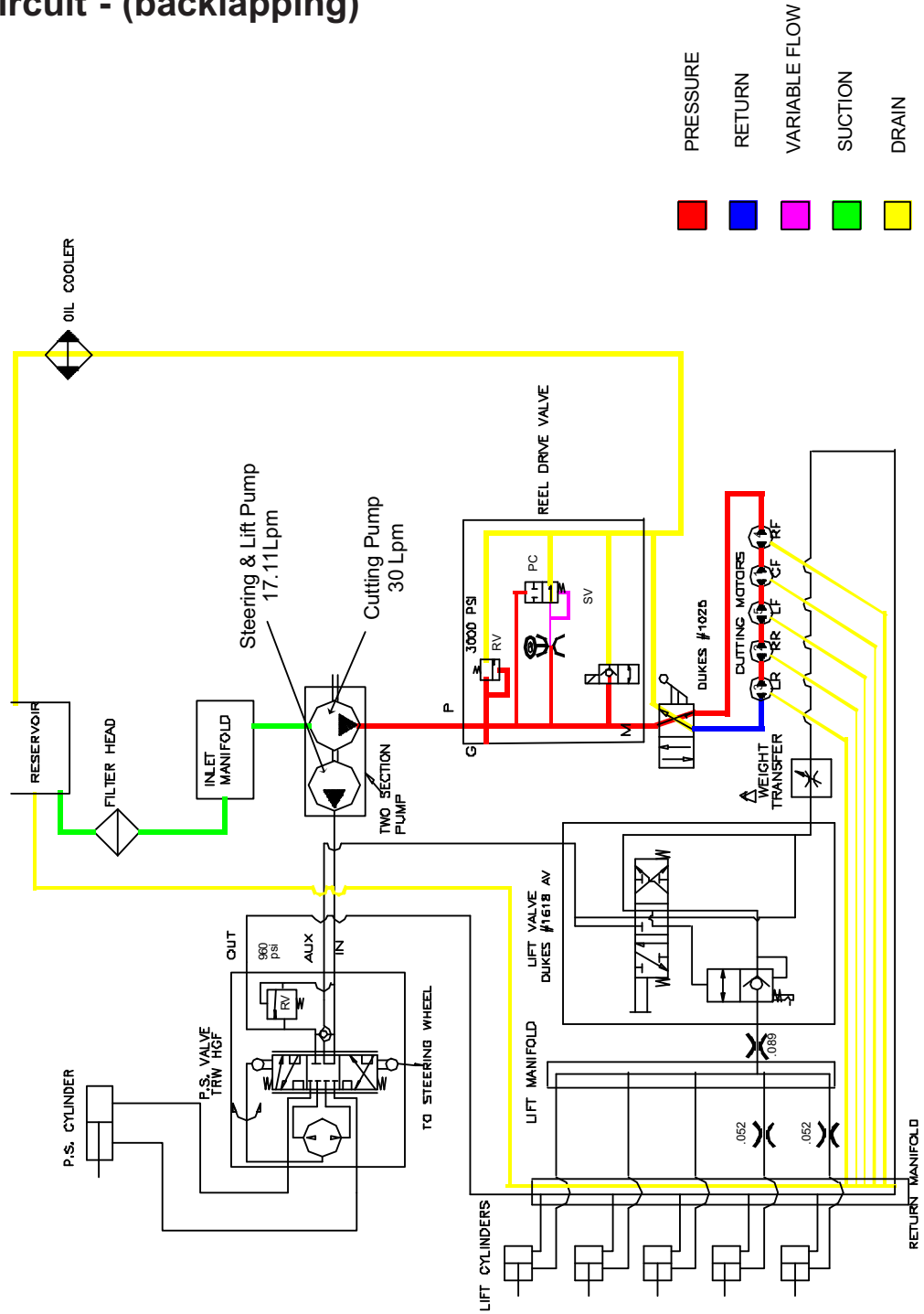

- PRESSURE
- RETURN
- VARIABLE FLOW
- SUCTION
- DRAIN

All Machines Forwards - permanent 4WD

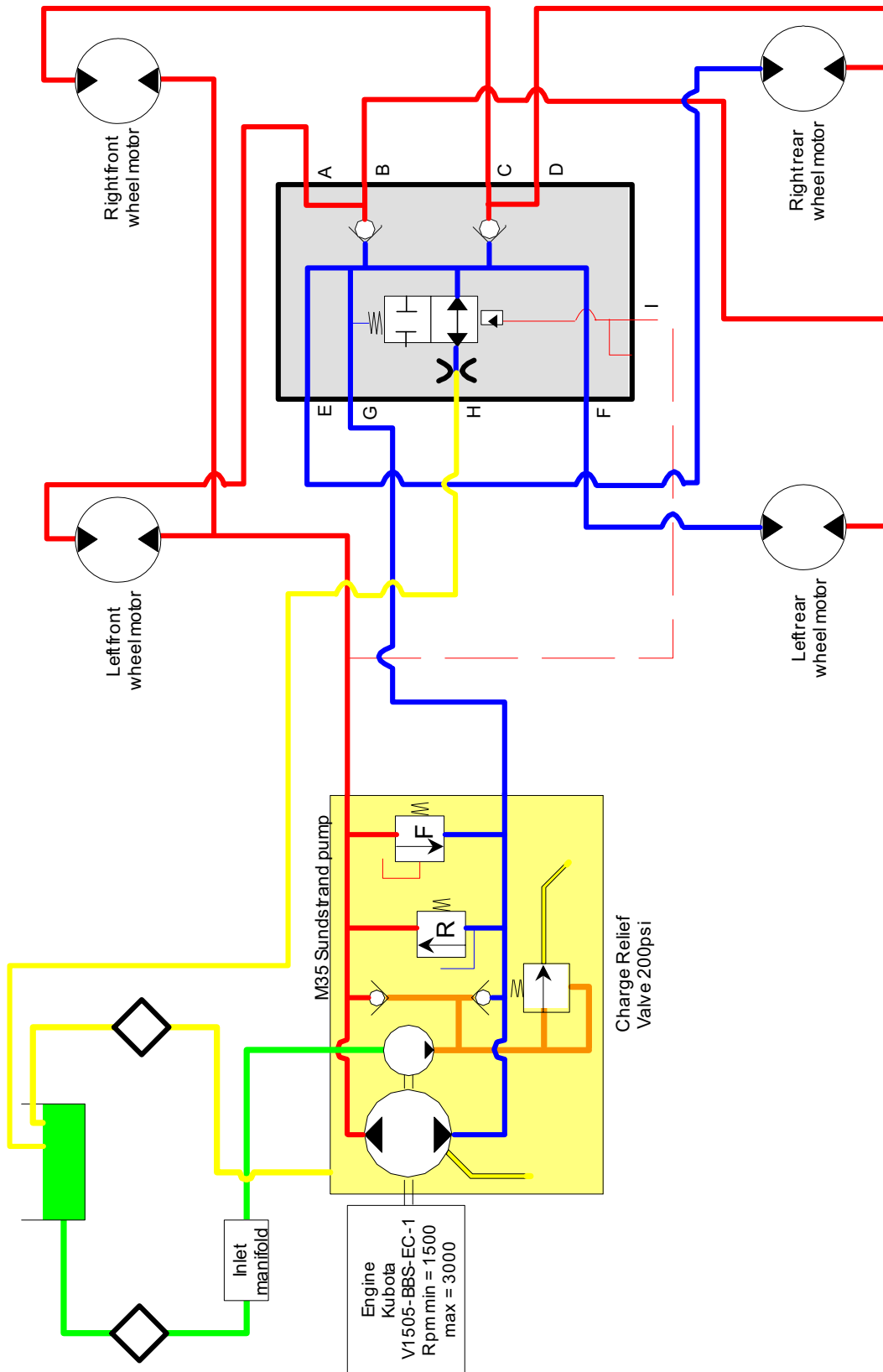

SECTION 4 ELECTRICS

AR 250 - Electrical Schematics

- 1 - Master Diagram
- 2 - Hot Circuit
- 3 - Pre heat position 1st 5 seconds
- 4 - Pre Heat position after 5 seconds
- 5 - Crank position
- 6 - Run position - driving machine
- 7 - Press mow switch - cut position
- 8 - Drop decks - activate cutter switch
- 9 - Lift lower lever to neutral
- 10 - Press foot switch to engage deck drive
- 11 - Machine cutting
- 12 - Raise cutter decks

Fairway 305 (EC) electrical schematic

Electric Circuit

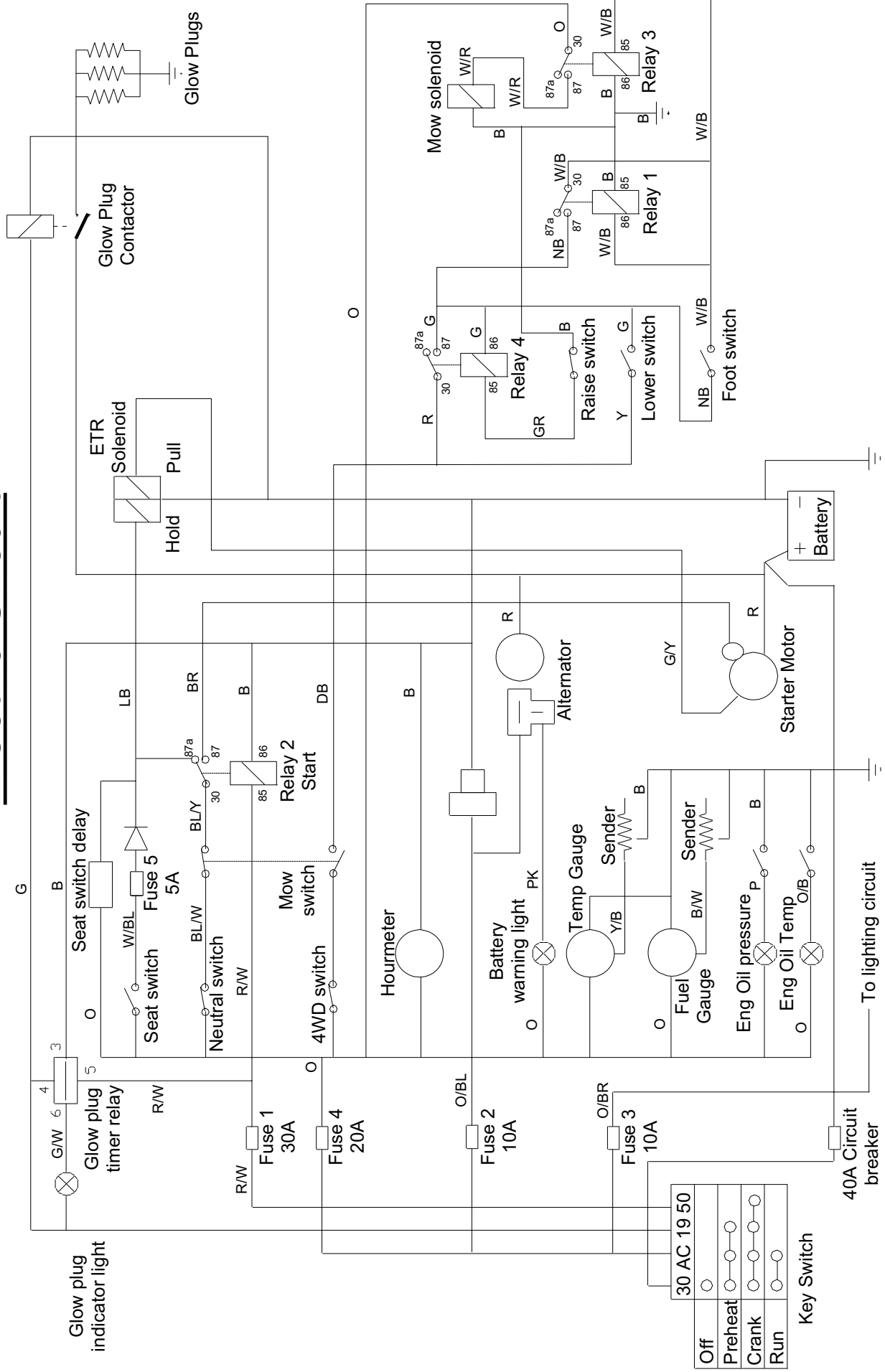

30 AC 19 50	○
Off	○ ○ ○ ○ ○
Preheat	○ ○ ○ ○ ○
Crank	○ ○ ○ ○ ○
Run	○ ○ ○ ○ ○

Key Switch

40A Circuit breaker

To lighting circuit

Off position

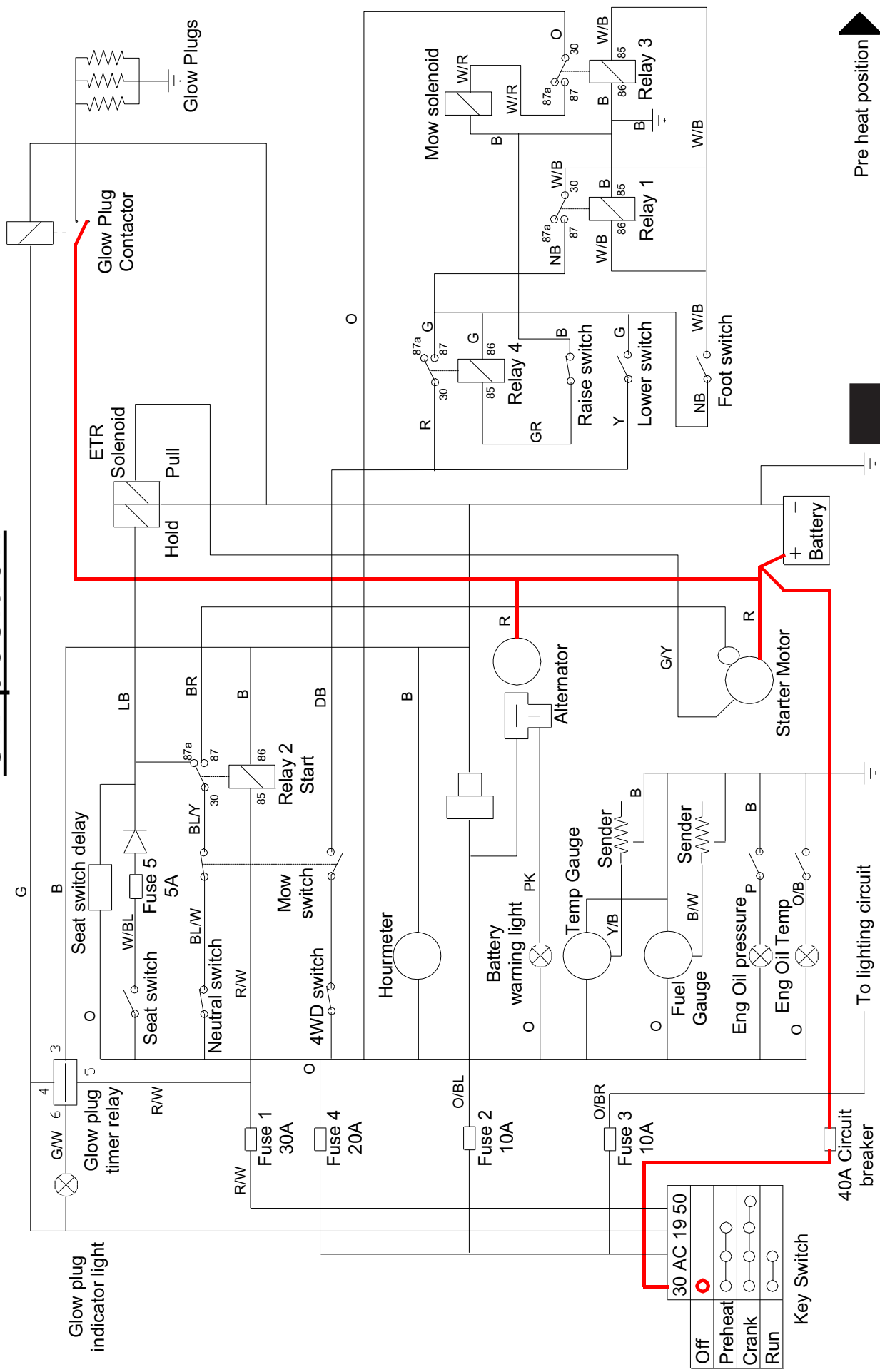

4

Pre heat position

30 AC 19 50	
Off	<input checked="" type="radio"/>
Preheat	<input type="radio"/>
Crank	<input type="radio"/>
Run	<input type="radio"/>

Key Switch

Pre-Heat position - 1st 5 seconds

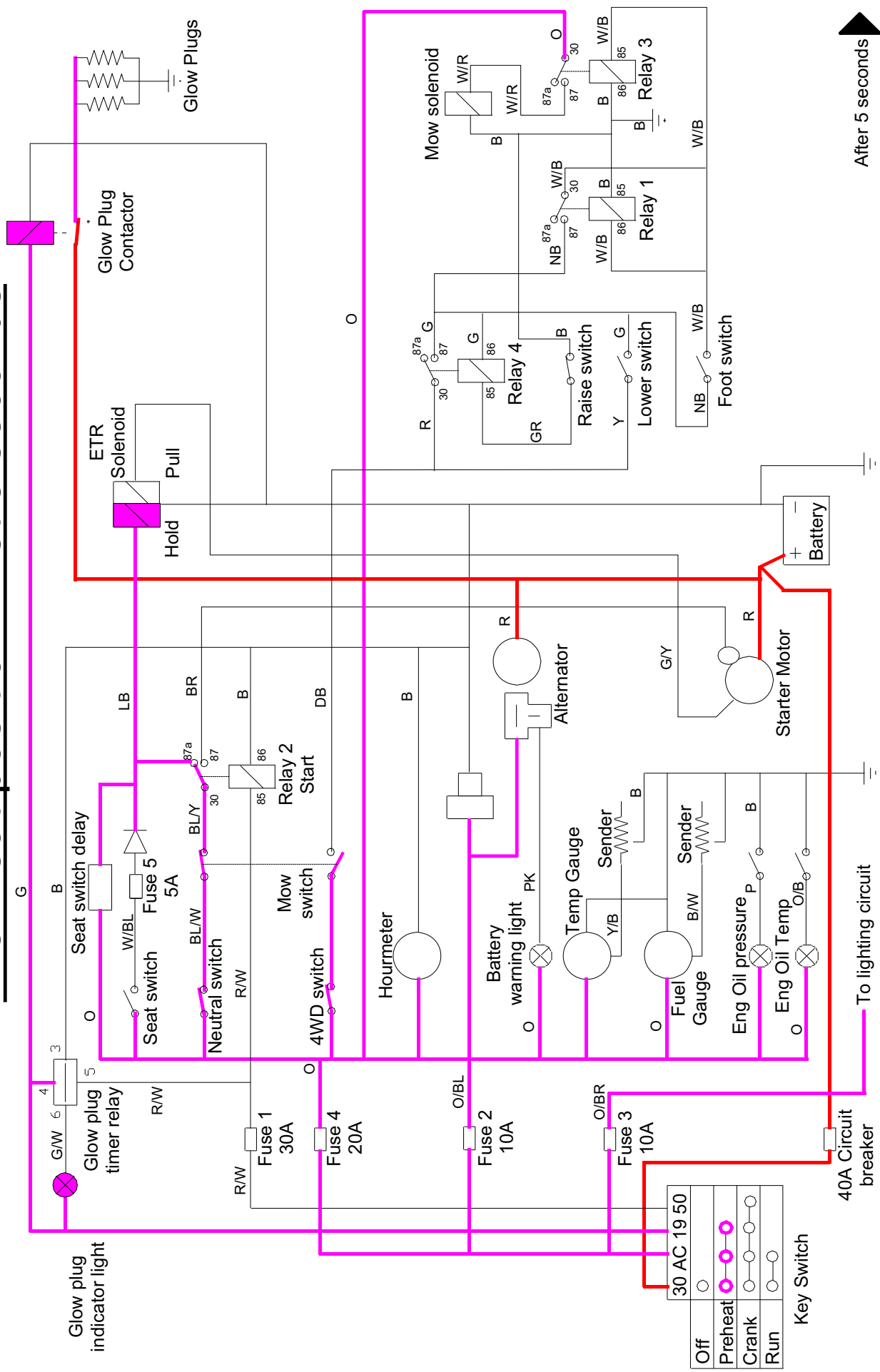

30 AC 19 50	○
Off	○
Preheat	●
Crank	○
Run	○

Key Switch

After 5 seconds

Pre-Heat position - after 5 seconds

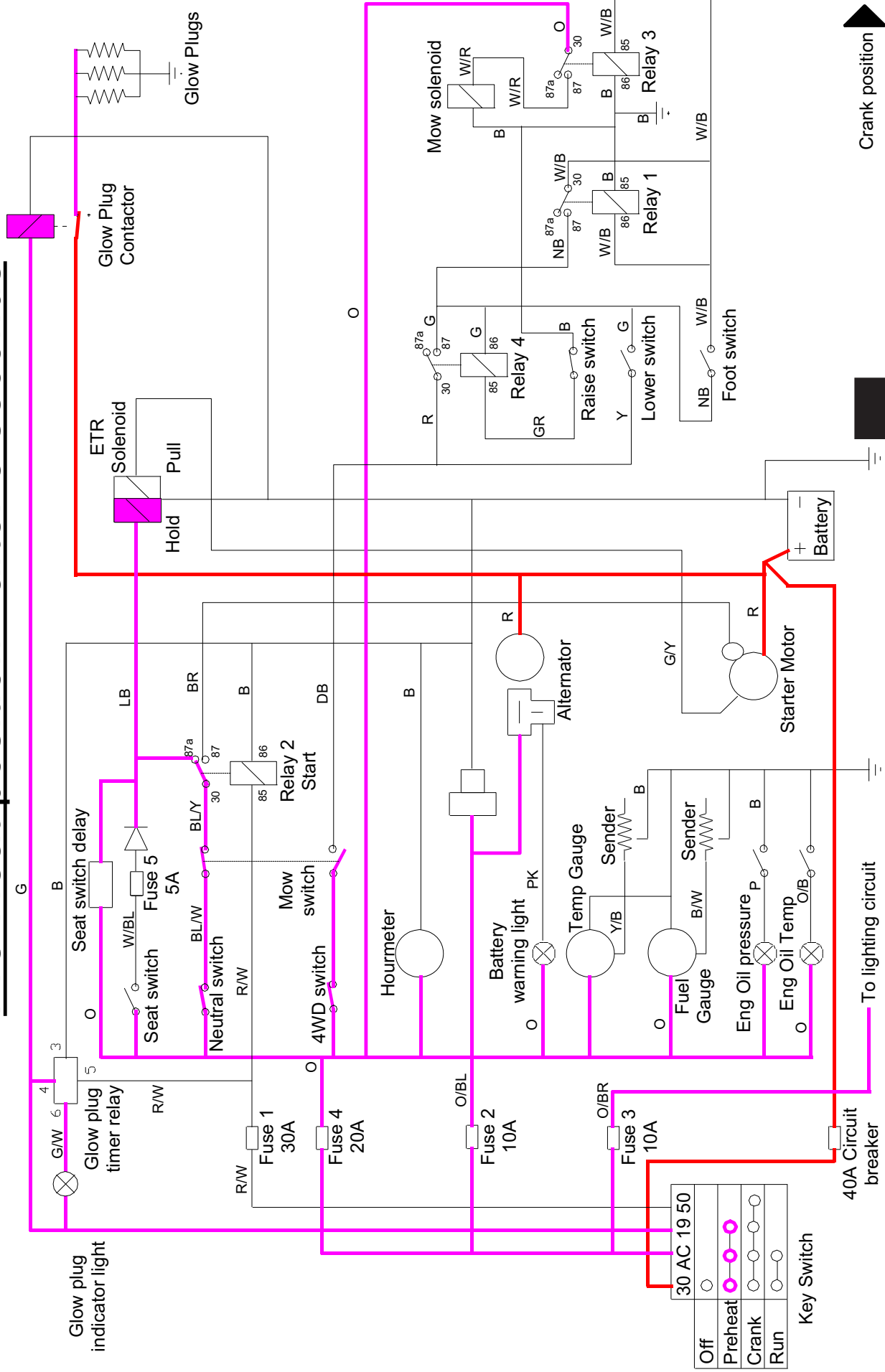

30 AC 19 50	○
Off	○
Preheat	●
Crank	○
Run	○

Key Switch

4

▲ Crank position

Crank position

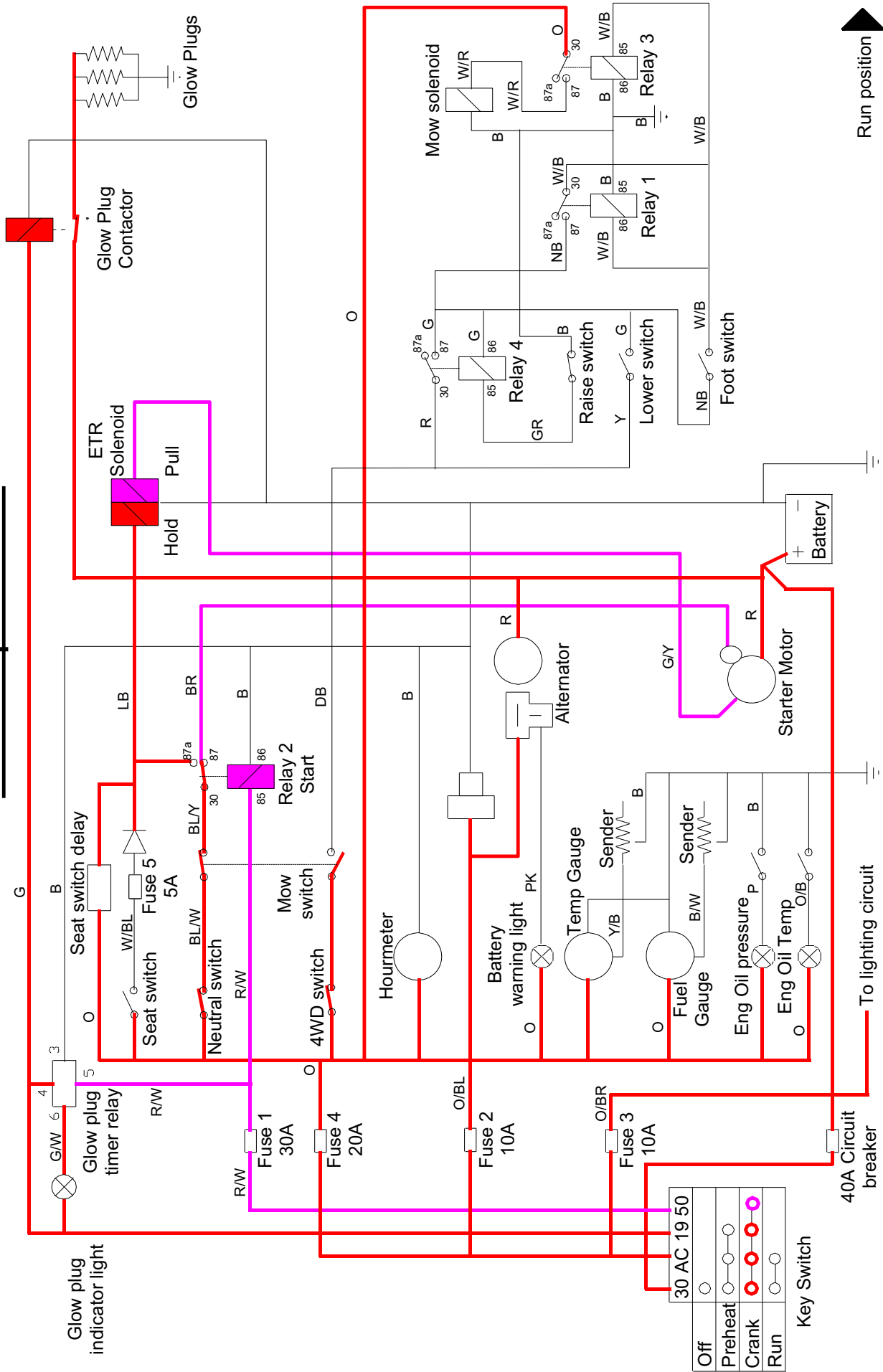

Run position

Run position - Driving machine

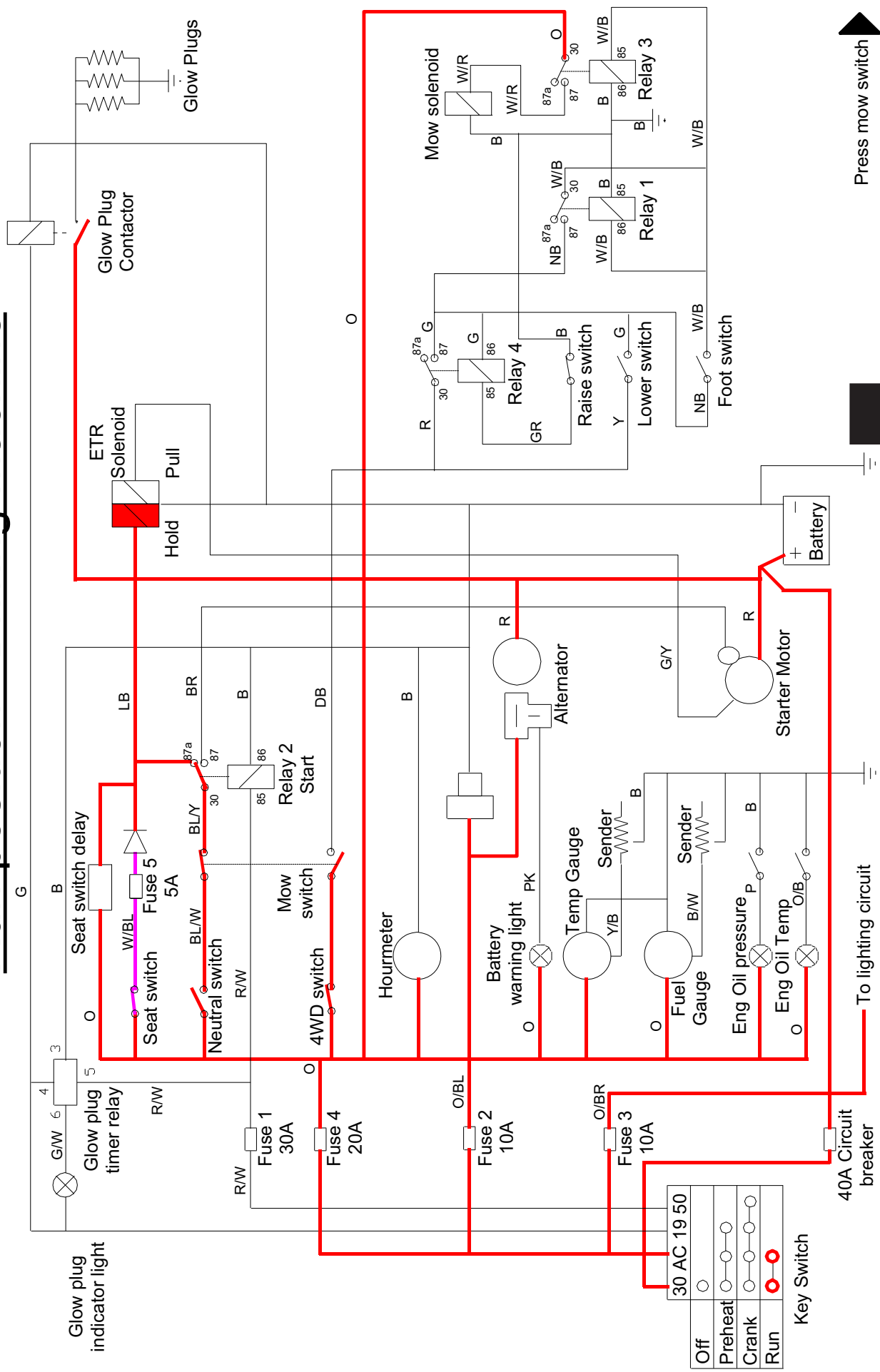

Press mow switch - cut position

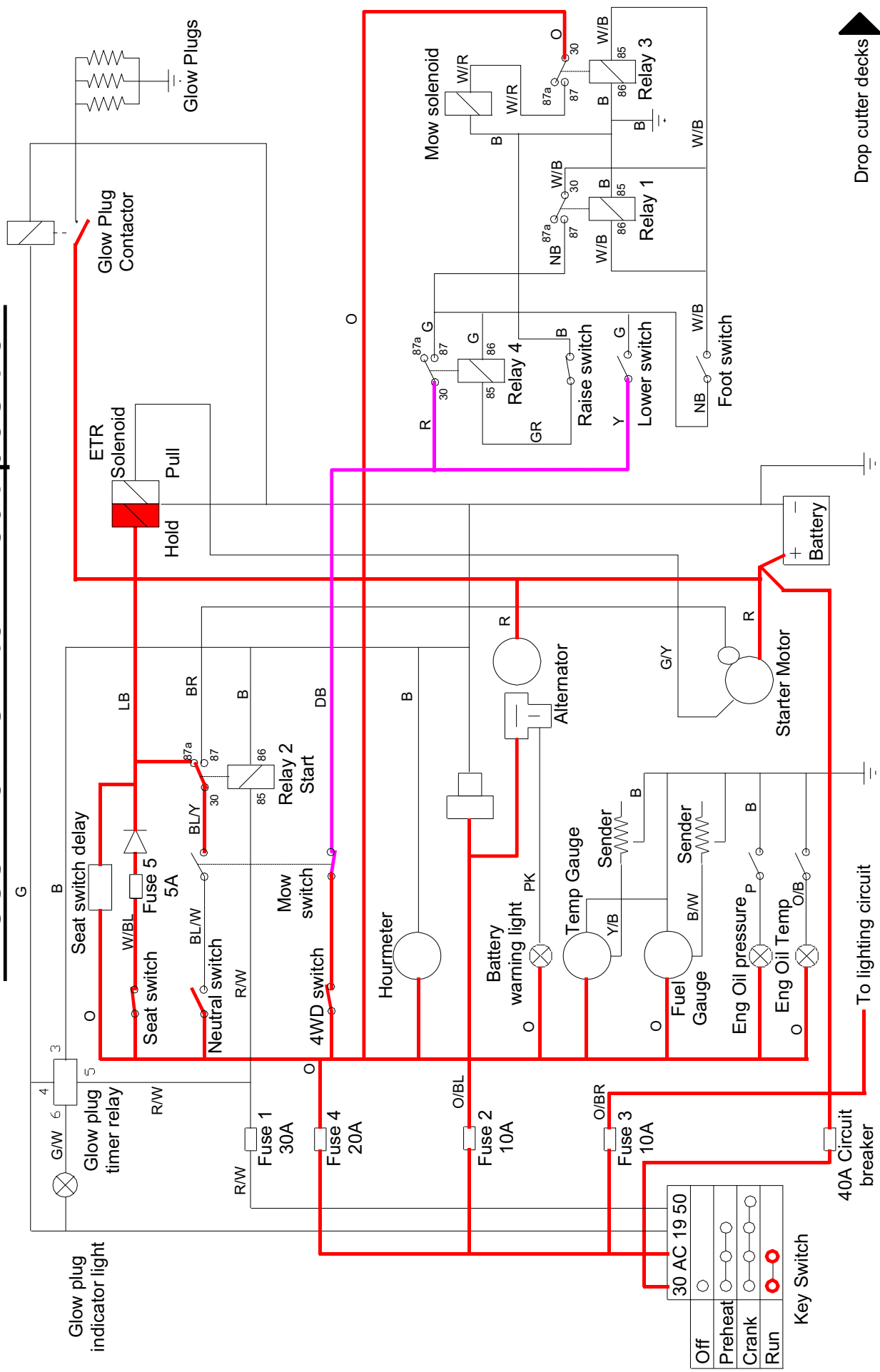

Drop cutter decks

Drop cutter decks - actuates lower switch

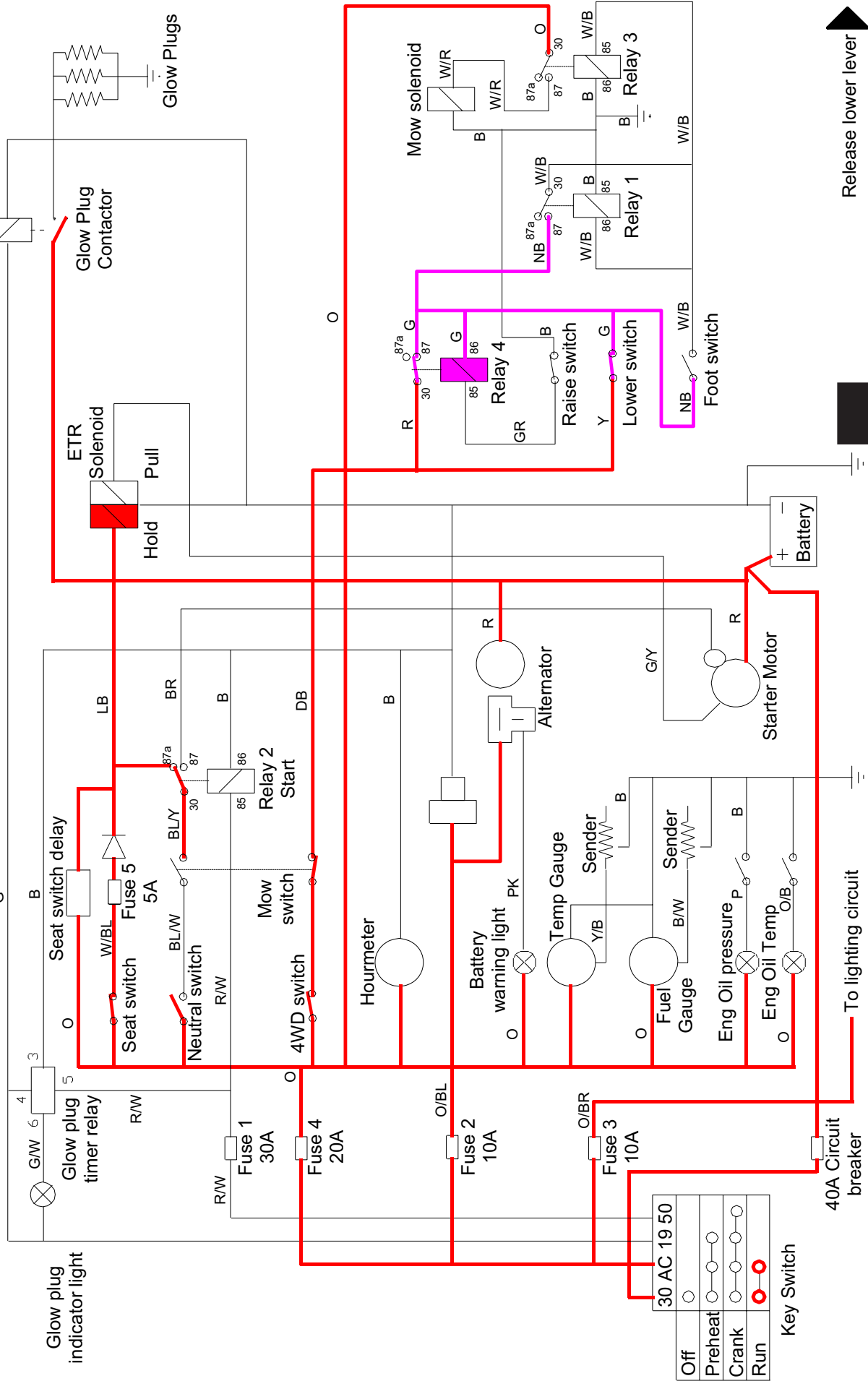

Lift/lower lever to neutral

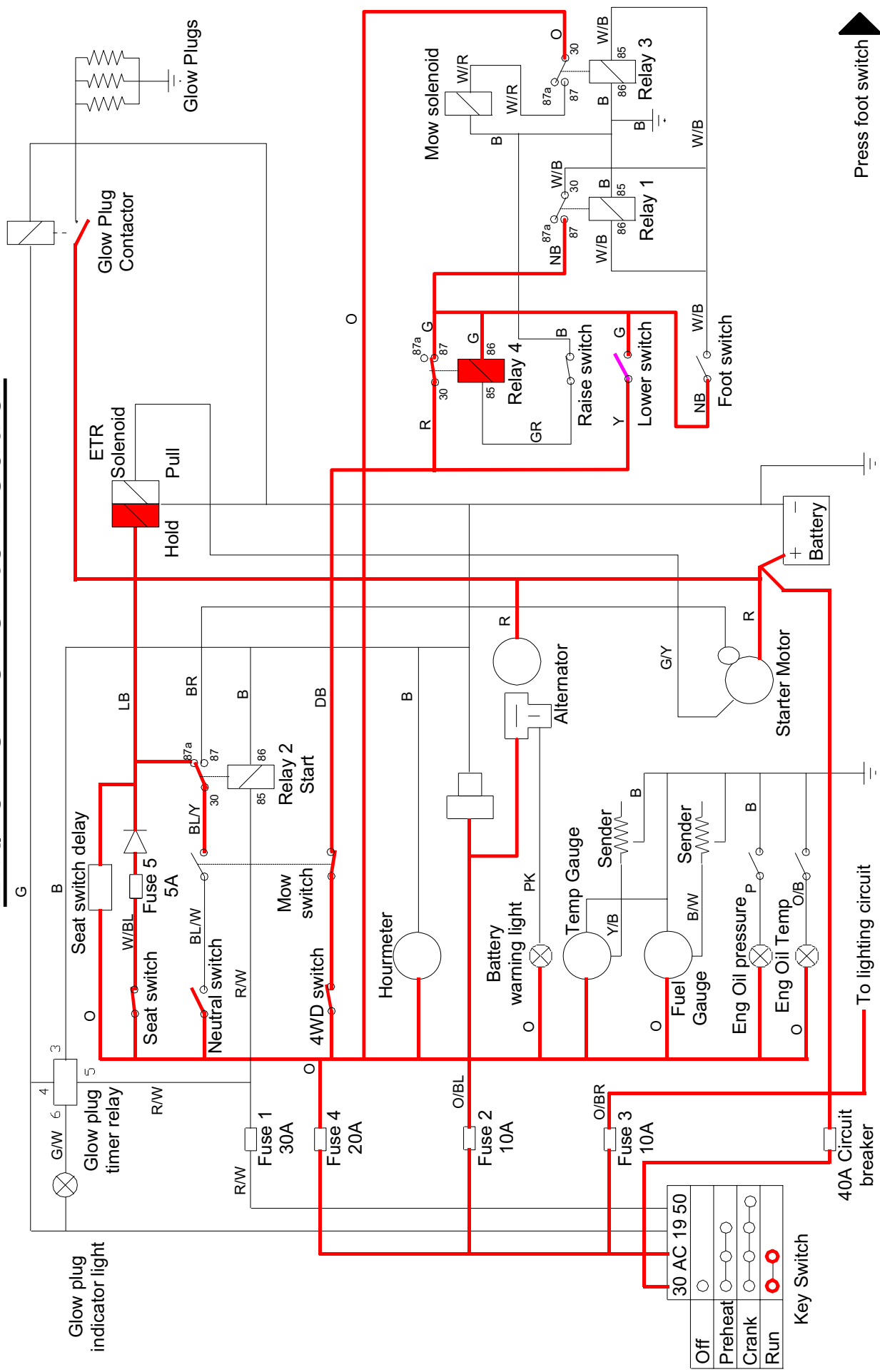

30 AC 19 50	○
Off	○
Preheat	○
Crank	○
Run	○

Key Switch

Press foot switch

Press footswitch to engage deck drive

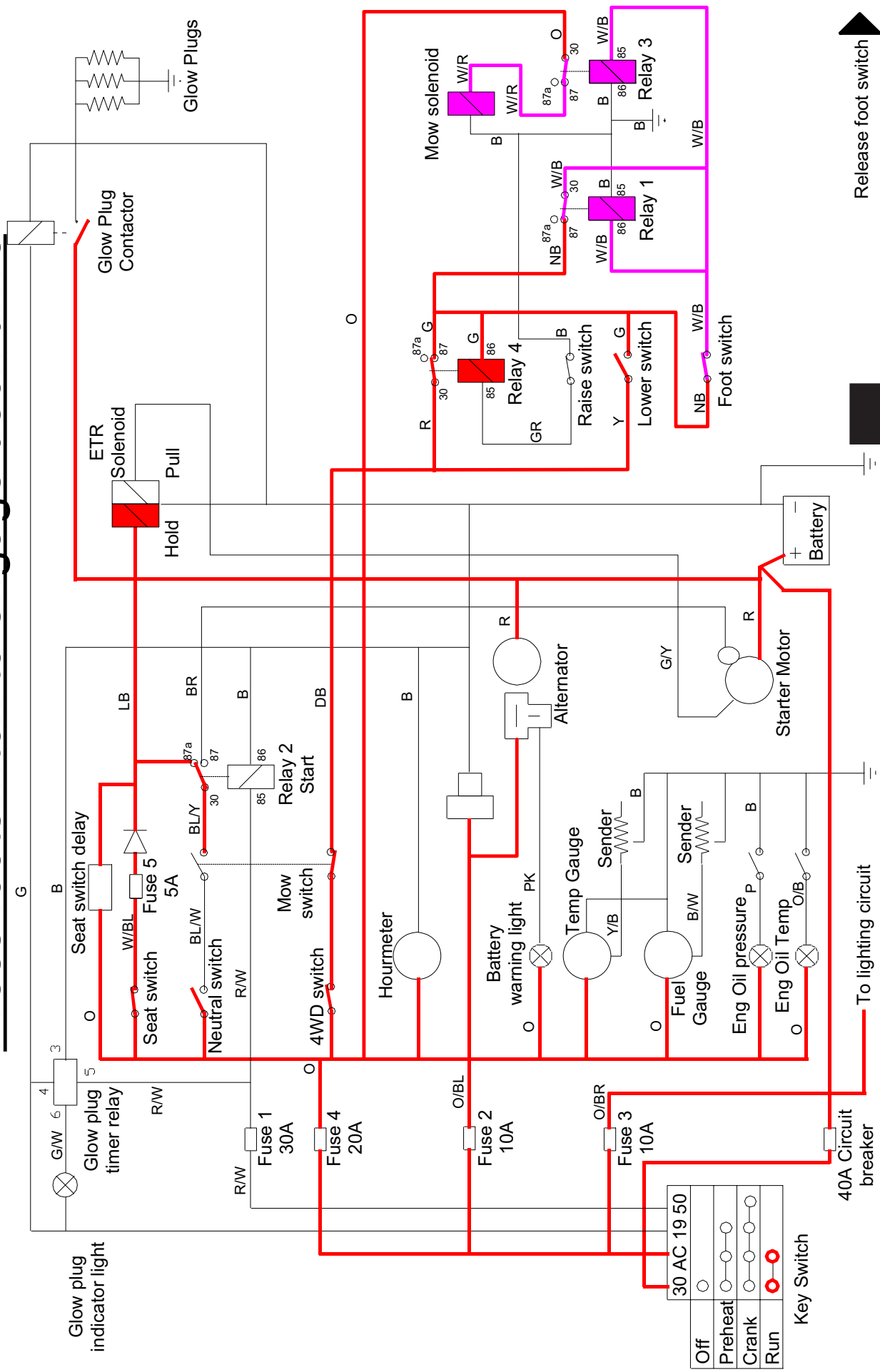

Circuit shown cutting

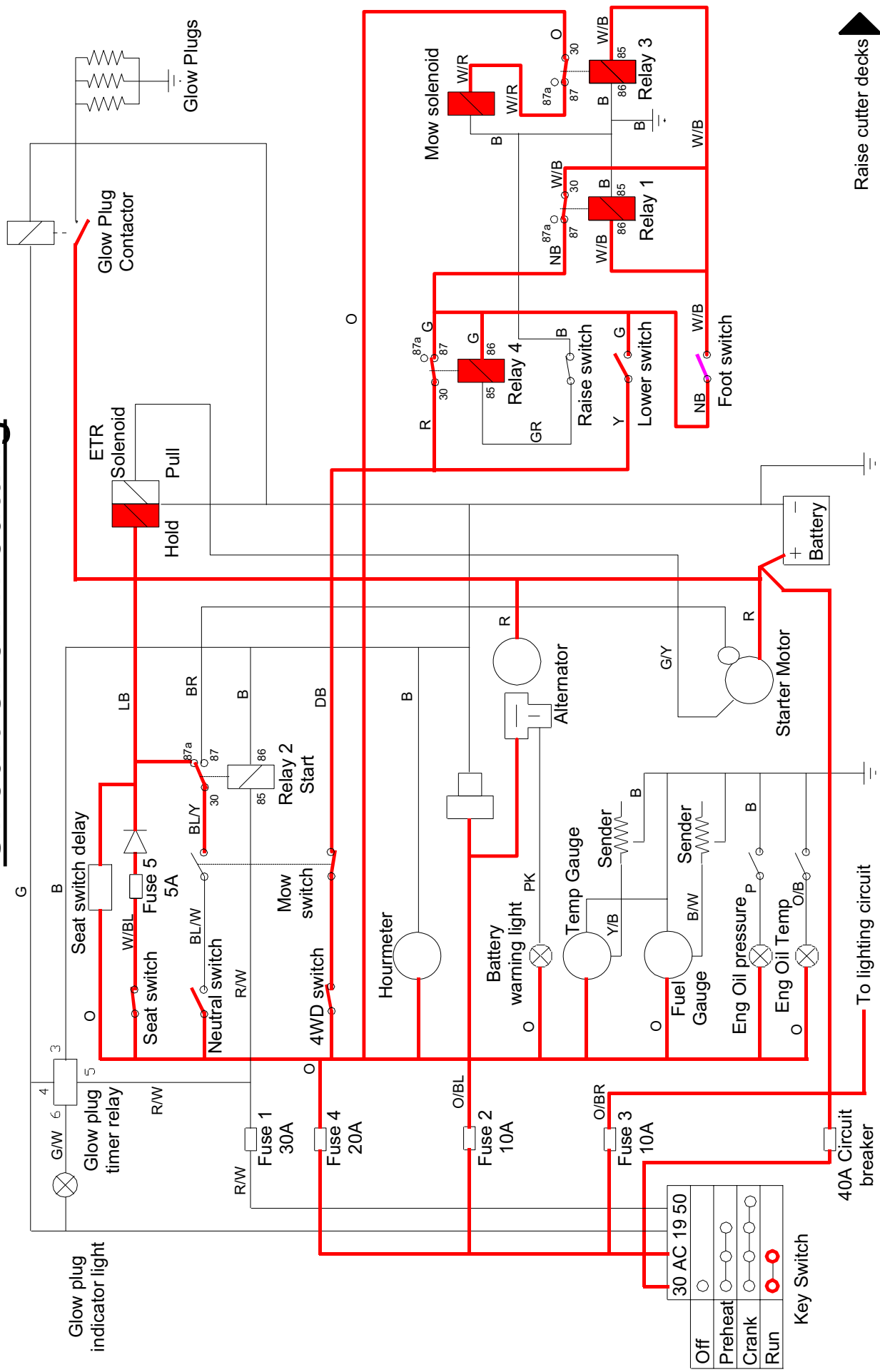

▲ Raise cutter decks

Raise cutter decks

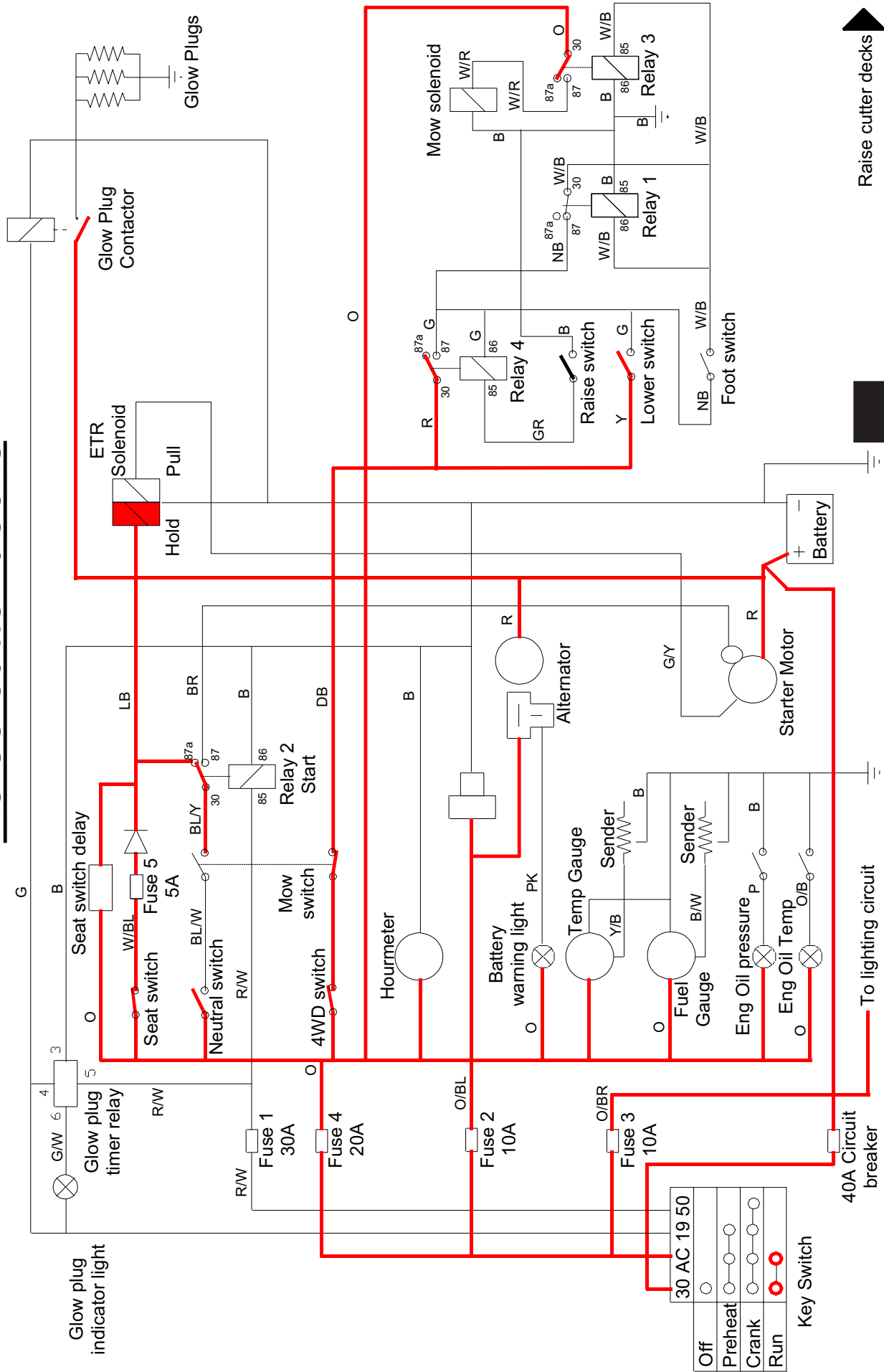

Raise cutter decks

Fairway 305 (EC) Electric Circuits

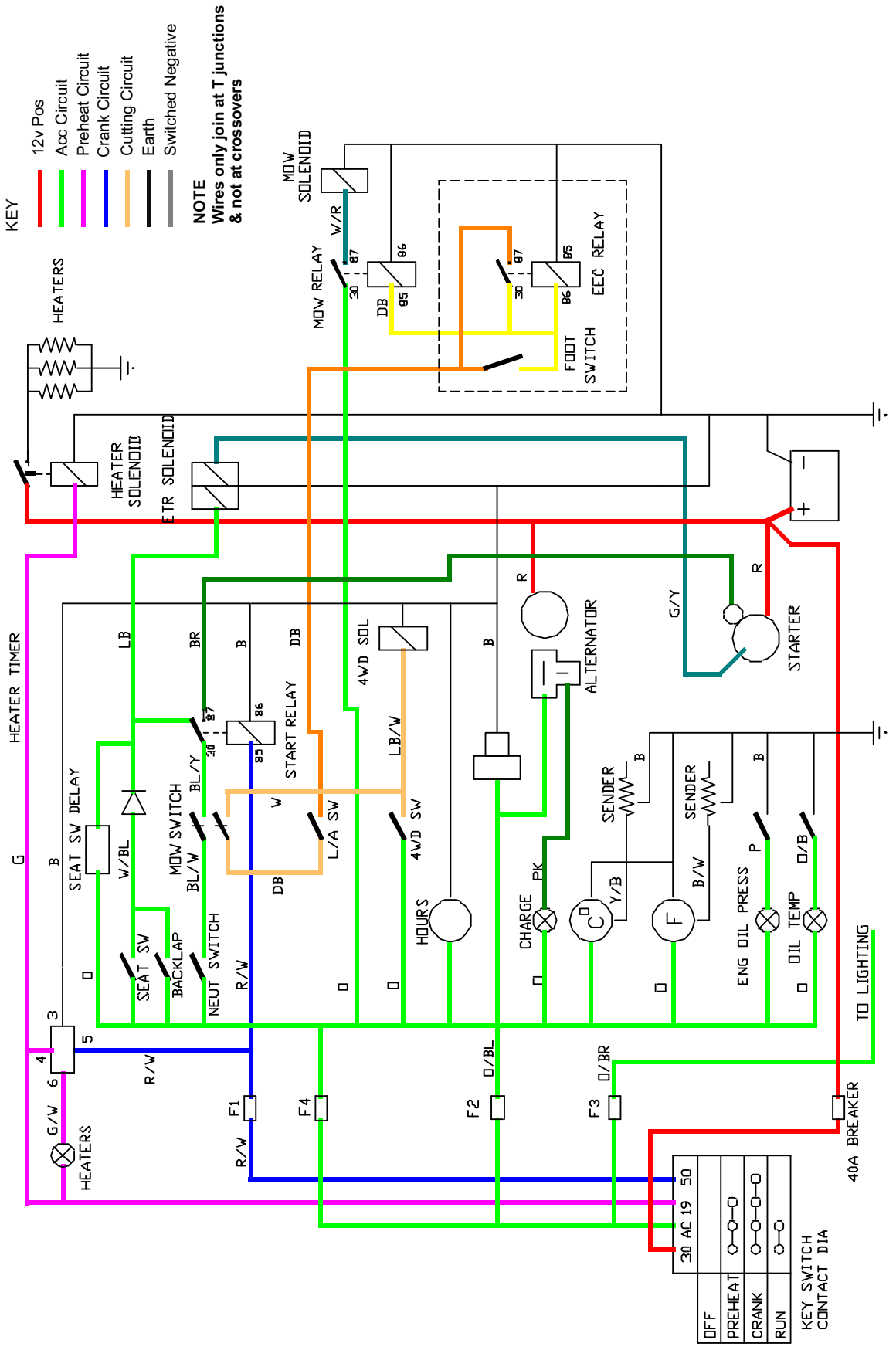



World Class Quality, Performance and Support

Equipment from Ransomes Jacobsen Limited is built to exacting standards ensured by ISO 9001 registration at all our manufacturing locations. A worldwide dealer network and factory-trained technicians backed by Ransomes Jacobsen Parts Xpress provide reliable, high-quality product support.